

REV	DATE	BY	DESCRIPTION
-	24-7-2014	AvD	REFERENCE DRAWING E0011932

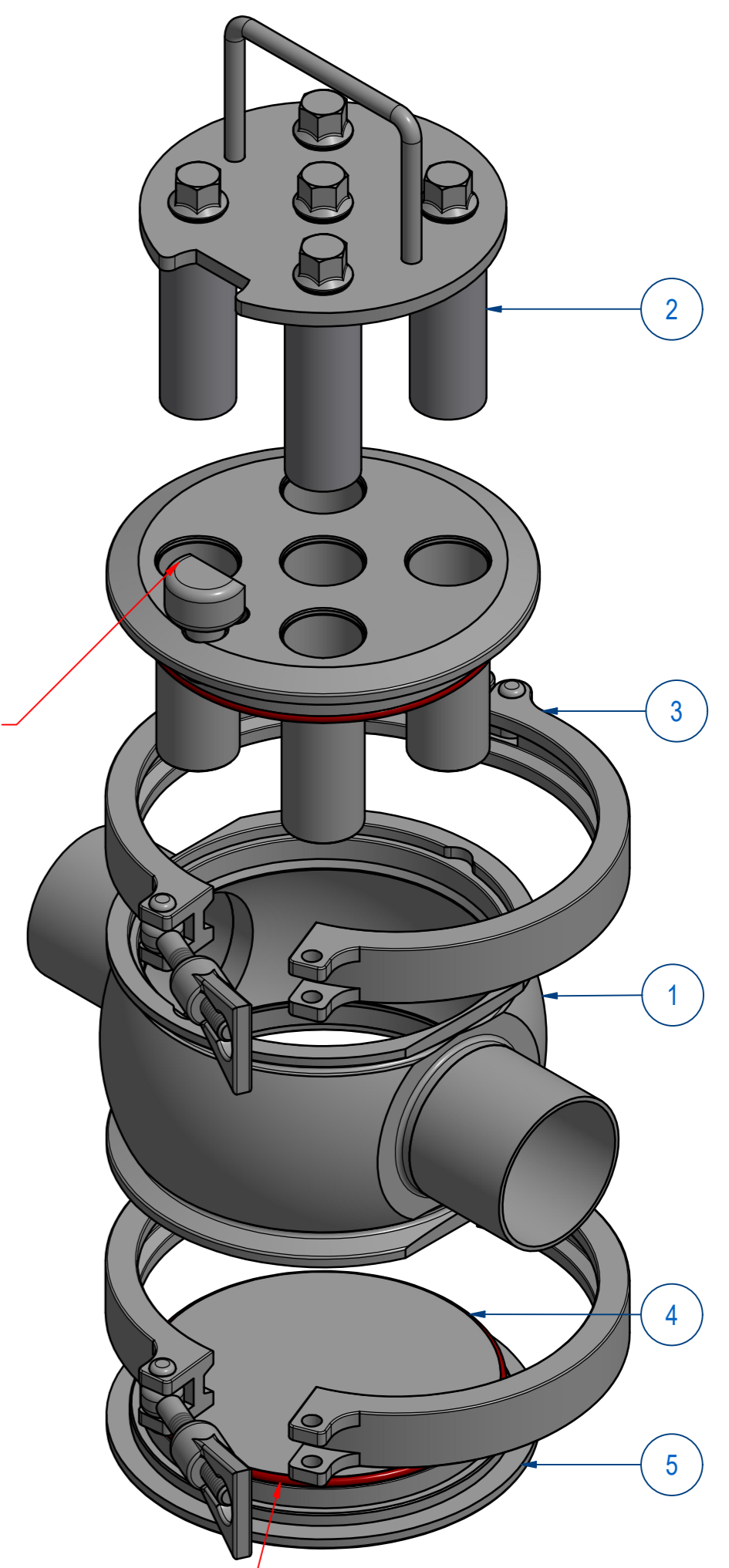

CLEANING PROTECTION

SEAL CONFORM TO HYGIENIC DESIGN

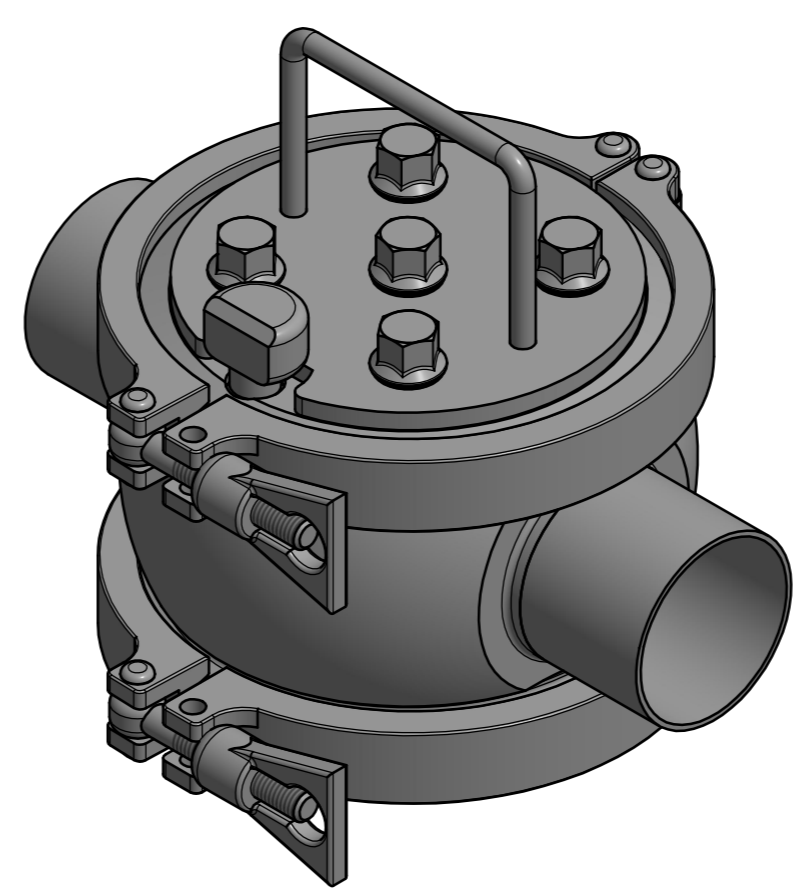
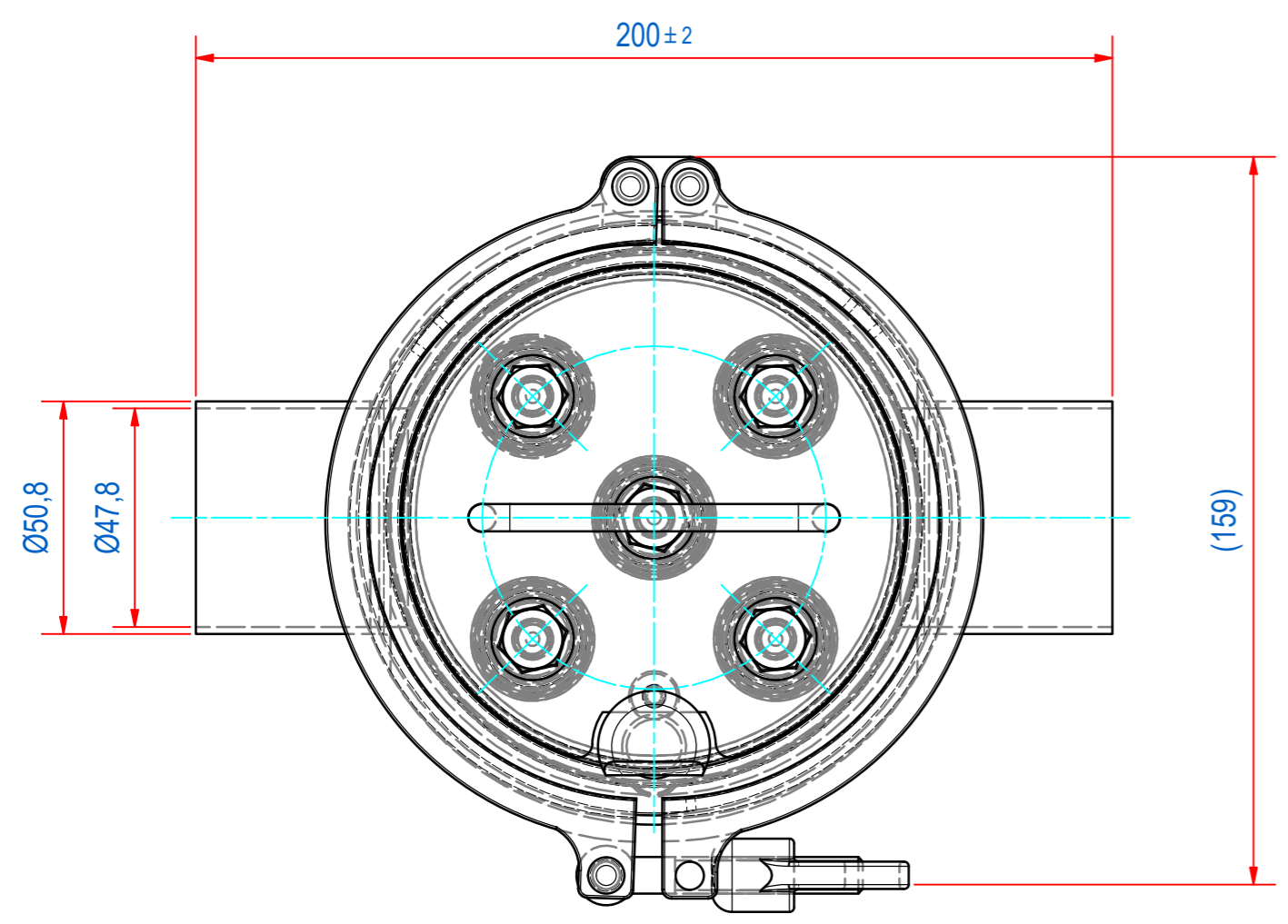
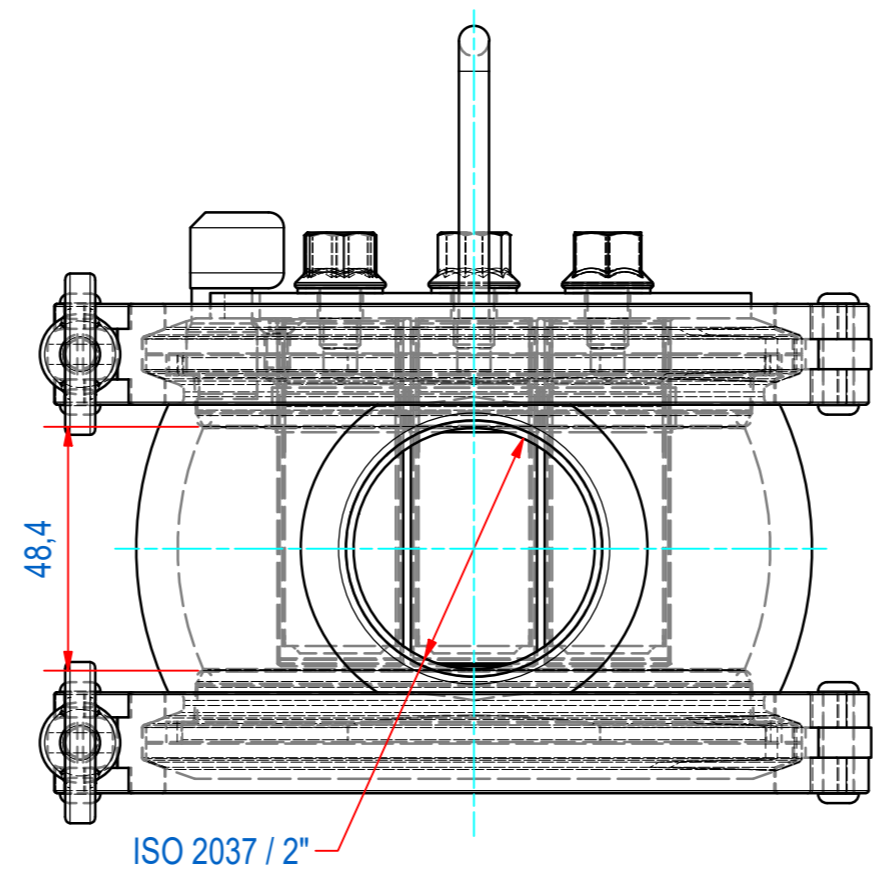
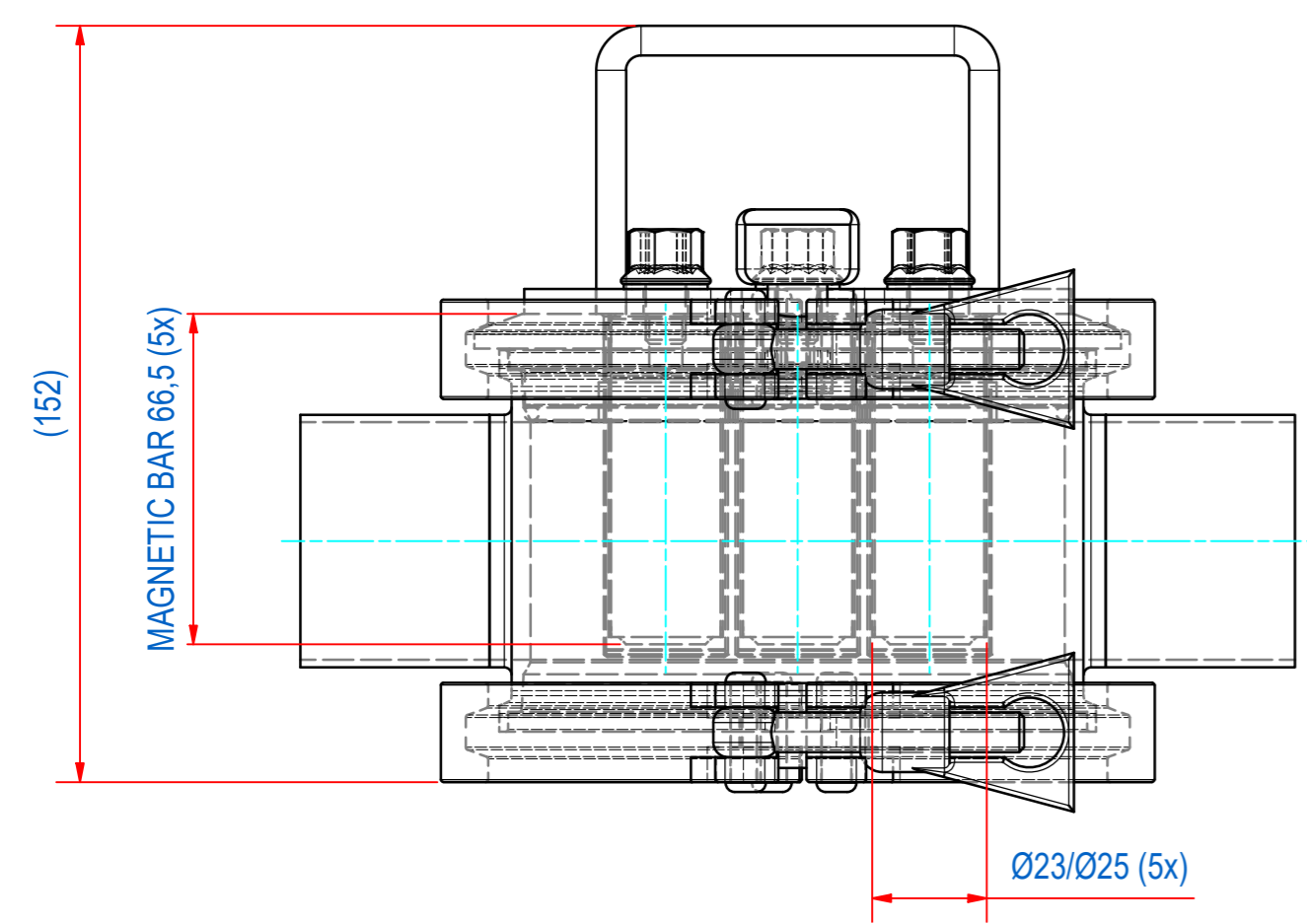

ITEM	QTY	PART NUMBER	DESCRIPTION	Dimensions
5	1	E0014904	SFH-000 BOTTOM PLATE 316L	
4	2	E0017388	SFH-S-000-S O-RING RED EC1935	
3	2	77.9630092	GPFI-TRI CLAMP D130	
2	1	E0019444	SFH-S-2"-05E-HT FILTER TOP	
1	1	E0016187	SFH-2"-T2 HOUSE 316L	

RAW MAT.	Quantity	Material Number	Material Description	Length (mm)	Width (mm)
⊕	1				
Sheet:	A2		Extra info:	General tolerance: ISO 2768 - mK	
Drawn:	AVD		Weight (kg): 7,8	Drawn according: ISO286; ISO1101; ISO2553	
Date:	24-7-2014			Status: Standard	
Spare part:	False			Customer reference number:	
Quick search:	SFH-2"		<p>© All rights reserved. Reproduction is not permitted without written permission of GOUDSMIT Magnetic Systems BV</p>	Document number:	Doc.Rev:
Description:	SFH-2"-T2-05E-HT-F5M-S-B-B-B			E0019443	-
				Part number:	Rev:
				E0019443	-