

DOC.NR.	REV	DATE	BY	DESCRIPTION
E0161045	-	17-8-2023	AvD	REFERENCE DRAWING E0153778

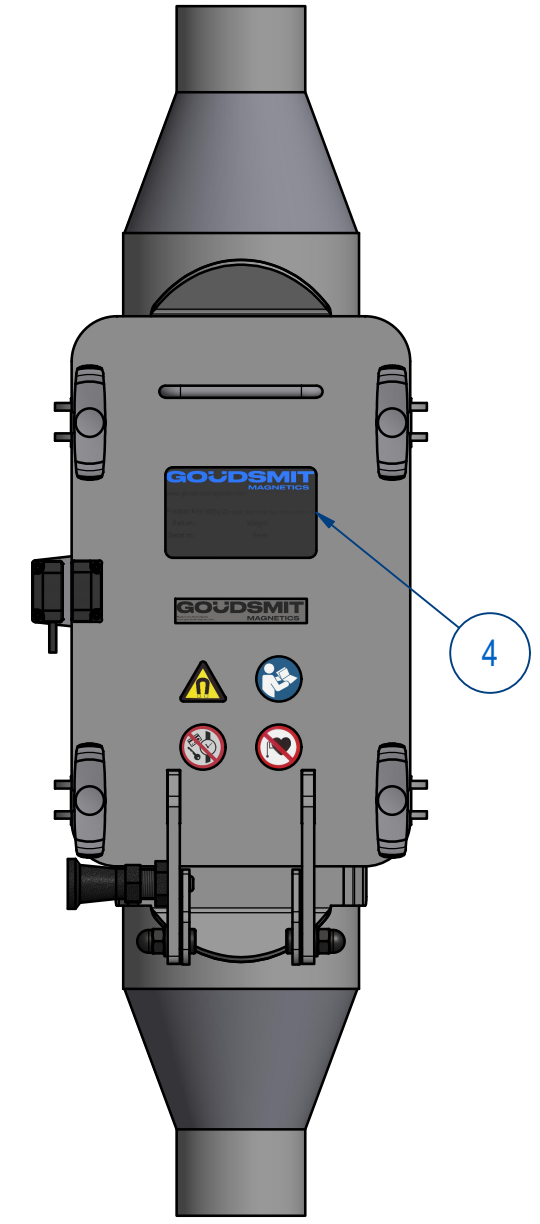

SAFETY SENSOR STEUTE Ex HS-Si-4 1NO+1NC

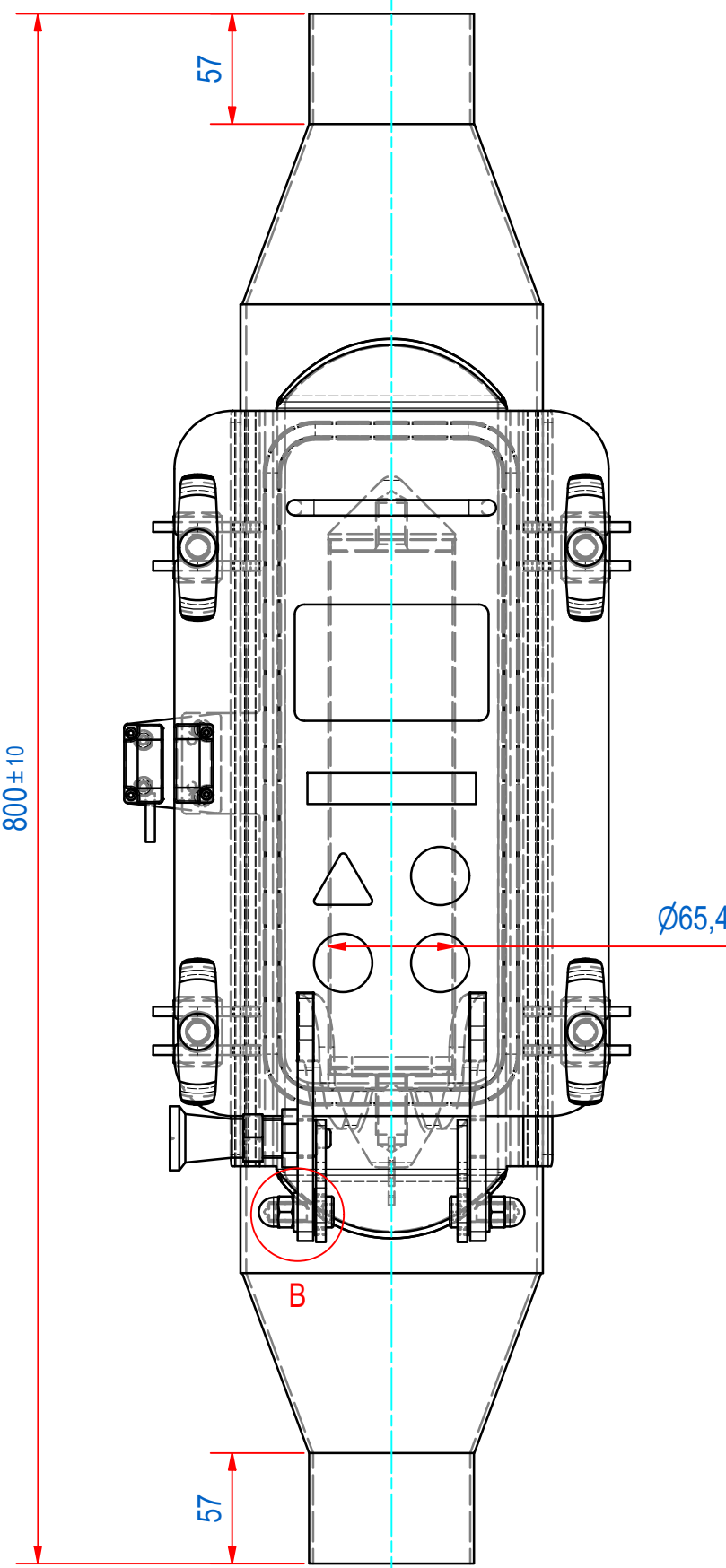
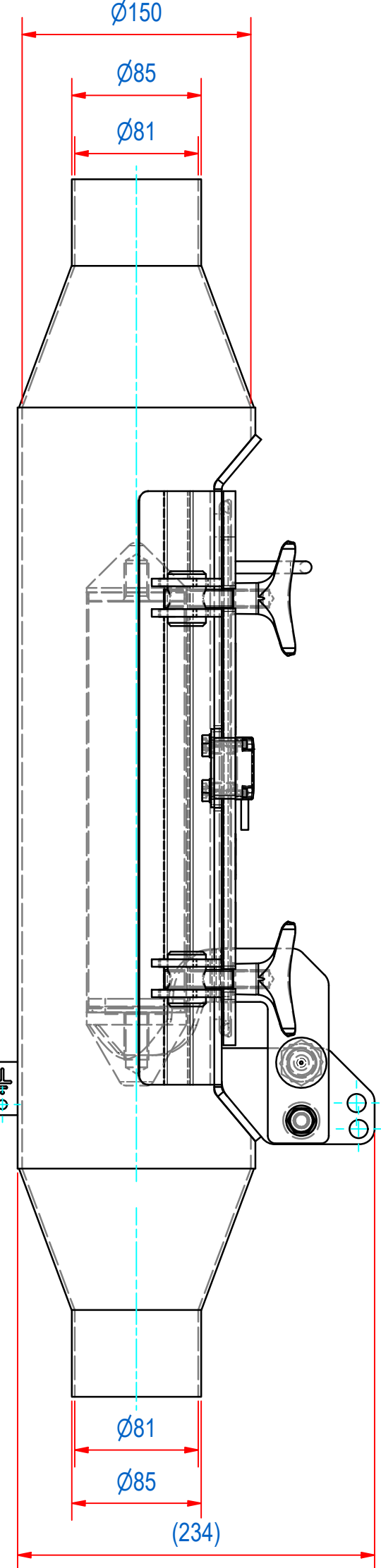
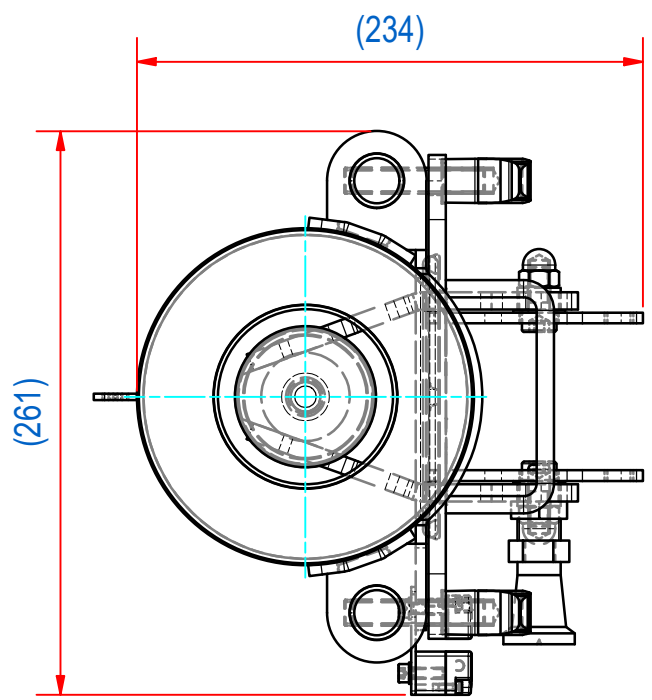
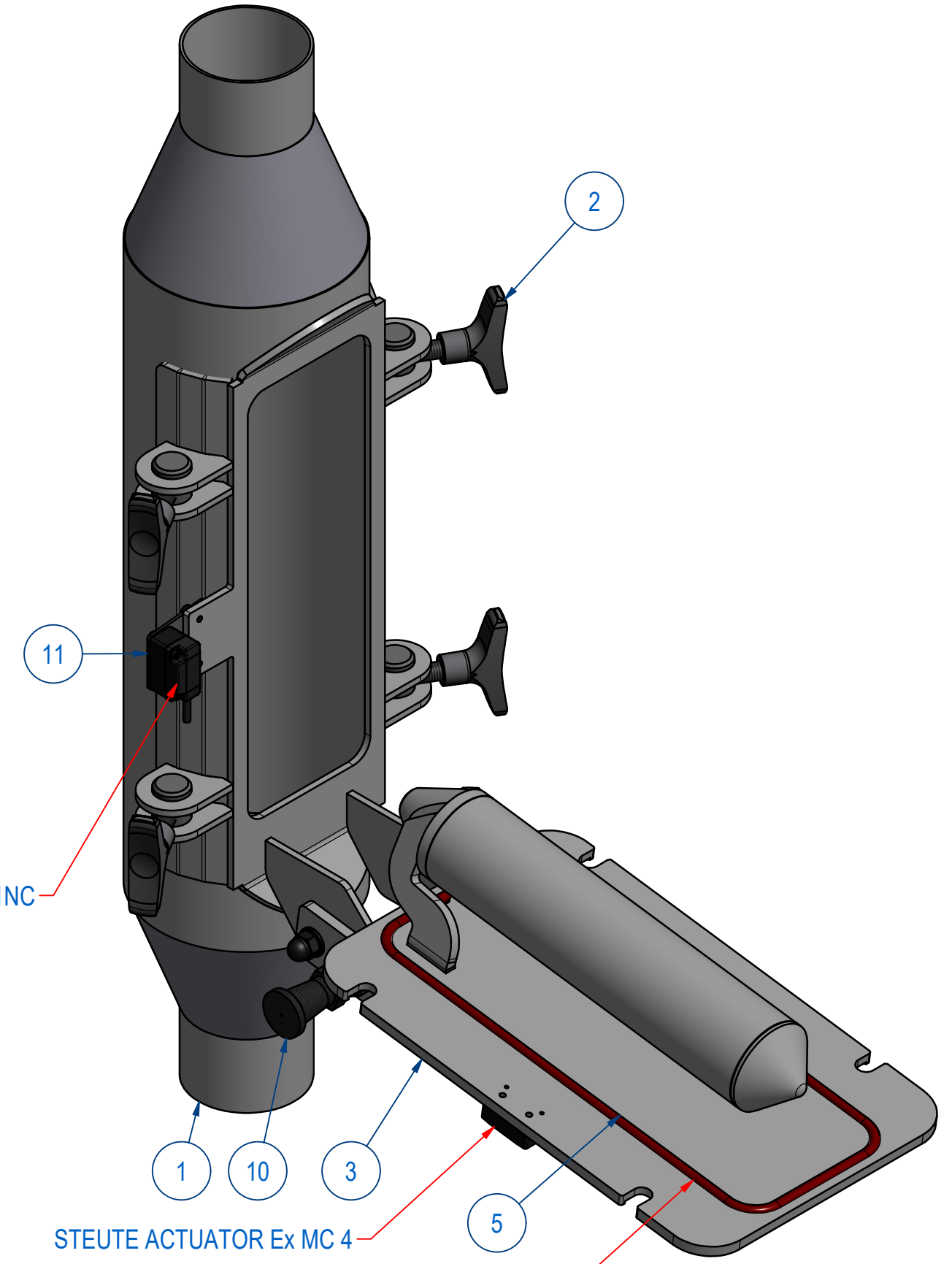

STEUTE ACTUATOR Ex MC 4

SEAL: O-RING SILICONE RED EC1935/2004

B (1:1)

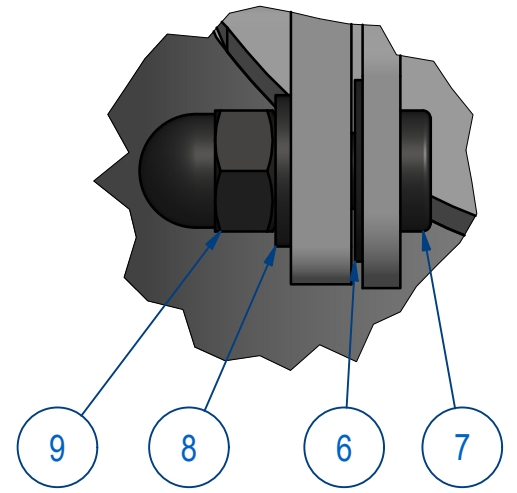

ITEM	QTY	PART NUMBER	DESCRIPTION	Dimensions
11	1	E0158569	SPN-000-STEUTE HS Si 4 Ex UNIT	
10	1	1005.90003	INDEXING PLUNGER D10 M20x1,5SS	
9	2	60.3300010	NUT, HEX CAP M10 - A4	M10
8	2	70.0300010	WASHER M10 - A4	M10
7	2	51.0310020	SCREW, HEX SH M10x20-A4	M10 x 20
6	2	15.0011618	BEARING IGLIDUR GFM-1618-06	
5	1	E0160974	SPN-S-O-RING SILIC. RED	
4	1	E0153785	SPN-000-TYPE PLATE+STICKERS	
3	1	E0160973	SPN-S-000-DOOR MAGNET INSERT	
2	4	E0153767	SPN-000 TOGGLE M12	
1	1	E0161046	SPN-080-T1-HOUSE	

RAW MAT.	Quantity	Material Number	Material Description	Length (mm)	Width (mm)
1	1				

Sheet: <b>A2</b>	Extra info: <b>MAGNETIC FILTER</b>	General tolerance: <b>ISO 2768 - mK</b>
Drawn: <b>AvD</b>	Weight (kg): <b>25</b>	Drawn according: <b>ISO286; ISO1101; ISO2553</b>
Date: <b>17-8-2023</b>		Status: <b>Released</b>
Spare part: <b>False</b>	Source:	Customer reference number:
Quick search: <b>SPN-080</b>		
Description: <b>SPN-080-T1-01K-HT-F1m-S-T2-B</b>	Document number: <b>E0161045</b>	Doc.Rev: <b>-</b>
	Part number: <b>E0161045</b>	Rev: <b>-</b>