

DOC.NR.	REV	DATE	BY	DESCRIPTION
E0161869	-	16-10-2024	EP	ADDED NXTdimPDM DESCRIPTION
E0161869	A	16-10-2024	EP	ORIGINAL DRAWING

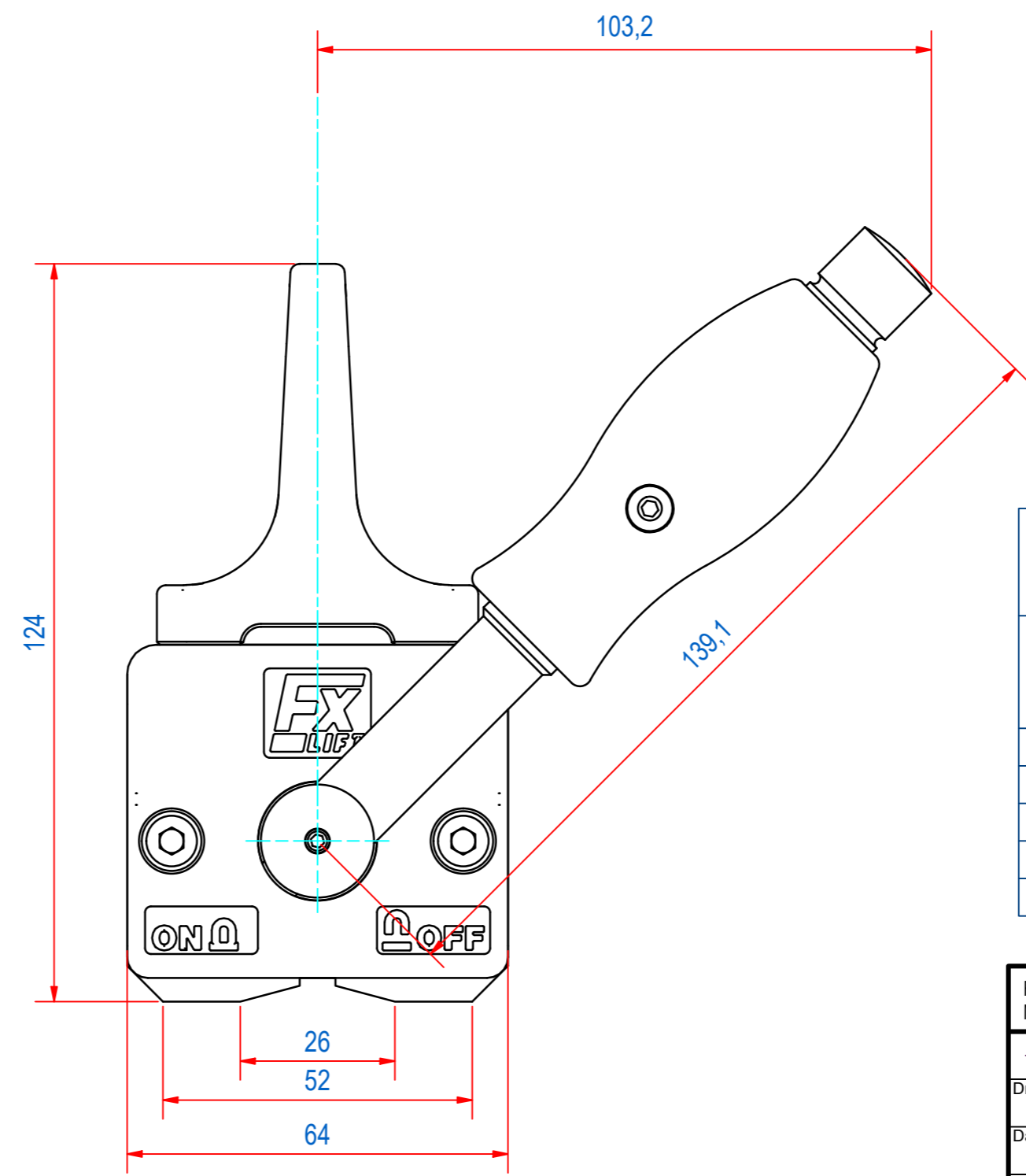

FX150	Air gap <0,1mm			Air gap 0,1- 0,3mm			Air gap 0,3- 0,5mm			
	Material Thickness (mm)	Max. Load (kg)	Max. L (mm)	Max. B (mm)	Max. Load (kg)	Max. L (mm)	Max. B (mm)	Max. Load (kg)	Max. L (mm)	Max. B (mm)
>=2	20	800	800	12	800	800	10	800	800	800
>=4	60	1500	1000	40	1500	1000	30	1200	1000	1000
>=6	80	1500	1000	60	1500	1000	50	1200	1000	1000
>=8	150	1500	1000	120	1500	1000	80	1200	1000	1000
Ø50-200	75	1500	-	50	2000	-	40	1500	-	-

RAW MAT.:	Quantity: 1	Material Number:	Material Description:	Length (mm):	Width (mm):
Drawn:	EP	Weight (kg): 3,6	General tolerance: ISO 2768- mK	Drawn according: ISO286; ISO1101; ISO2553	
Date:	12-10-2023	Source:	Status: Released	Customer reference number:	
Spare part:	False	Quick search:	FX-150	Document number: E0161869	Doc.Rev: A
Description:	HPL-RA-0150-064x161-060-FE			Part number: E0161869	Rev: A

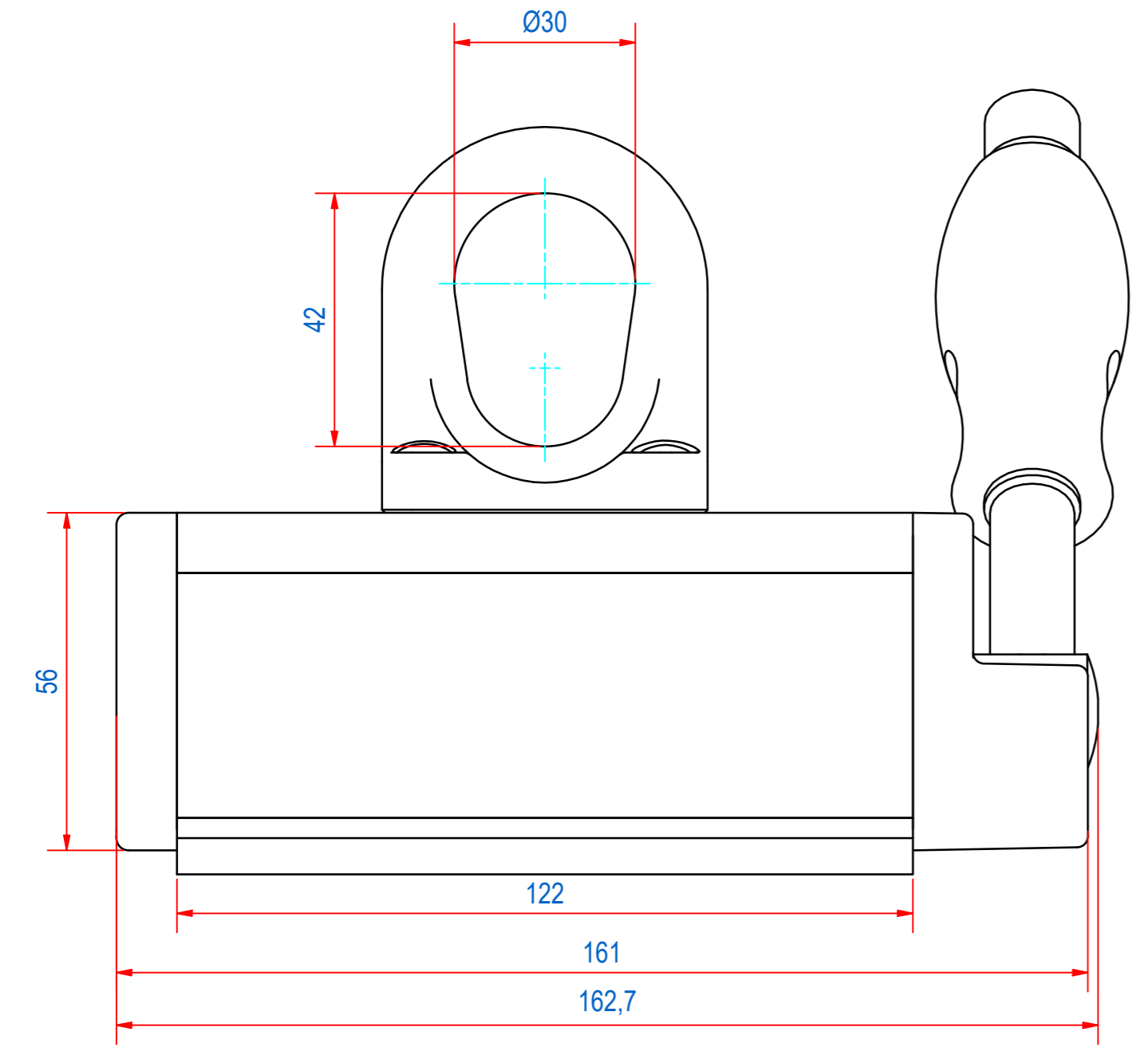
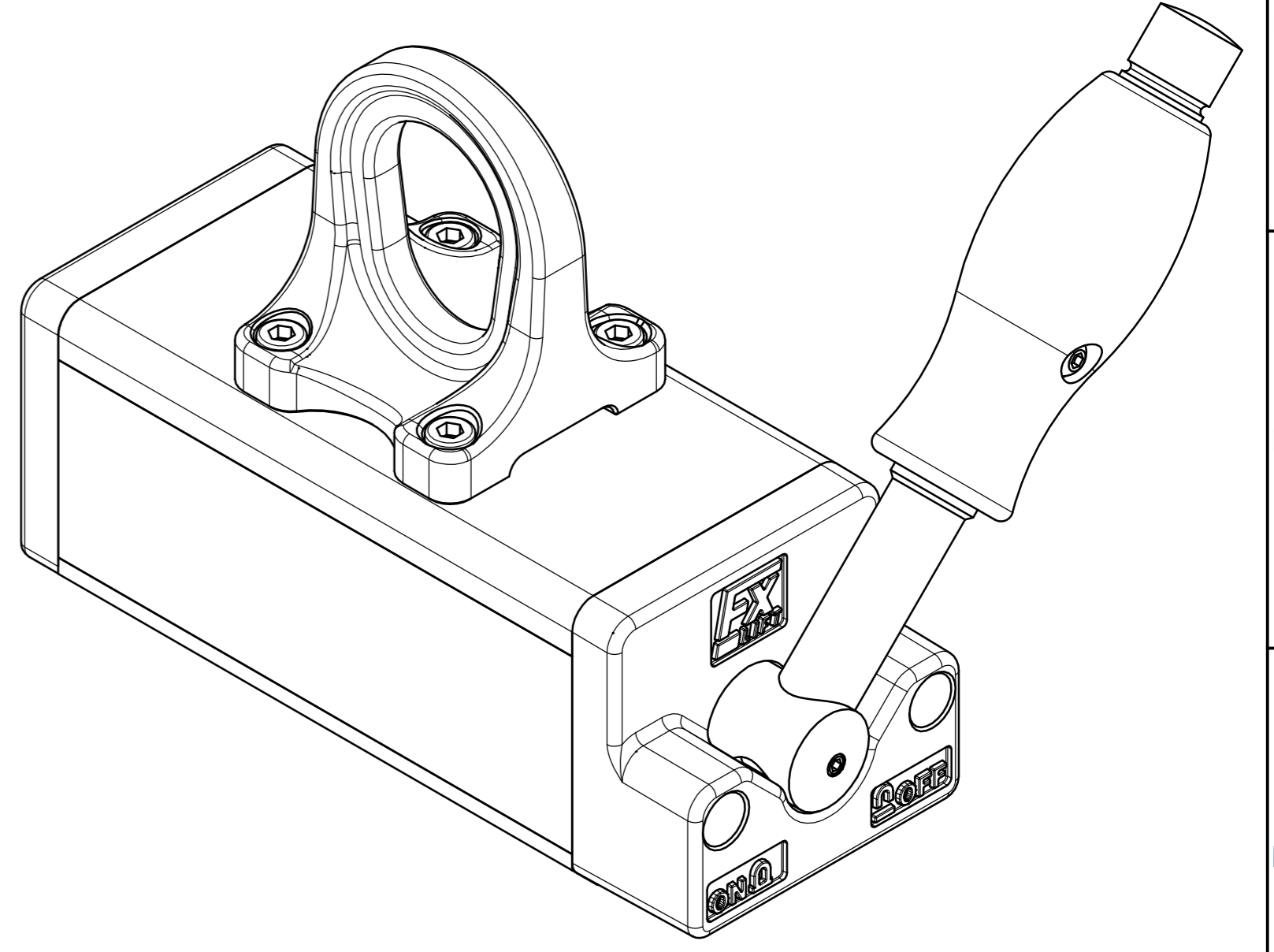
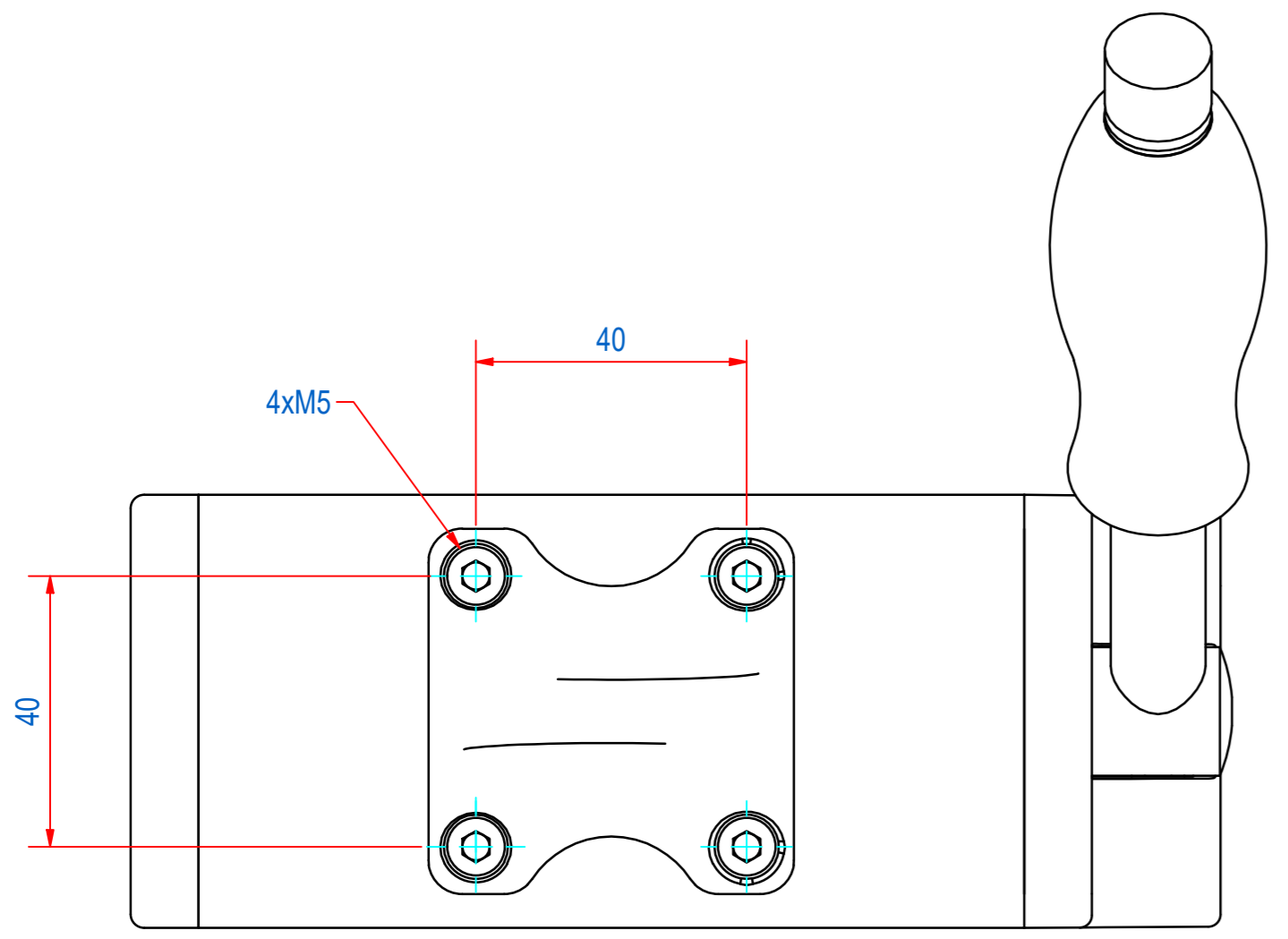

© All rights reserved. Reproduction is not permitted without written permission of GOUDSMIT Magnetic Systems BV