

DOC.NR.	REV	DATE	BY	DESCRIPTION
E0161874	-	16-10-2024	EP	ORIGINAL DRAWING
E0161874	A	16-10-2024	EP	ADDED CORRECT WEIGHT

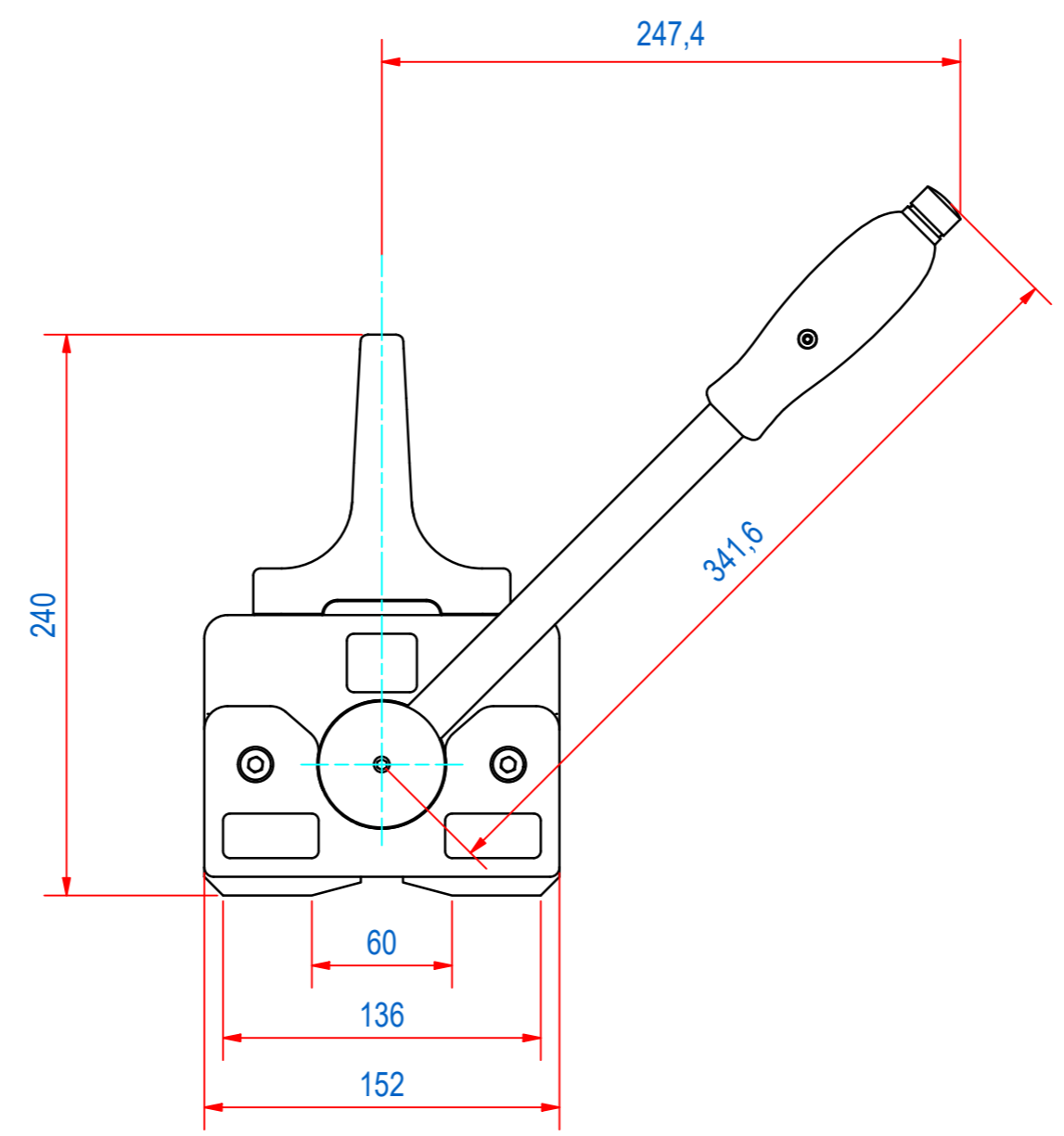

FX1500	Air gap <0,3mm			Air gap 0,3- 0,5mm			Air gap 0,5- 0,6mm		
Material Thickness (mm)	Max. Load (kg)	Max. L (mm)	Max. B (mm)	Max. Load (kg)	Max. L (mm)	Max. B (mm)	Max. Load (kg)	Max. L (mm)	Max. B (mm)
>=10	525	2250	2000	450	2250	2000	400	2250	1500
>=15	900	2500	2000	750	2500	2000	700	2500	1500
>=20	1300	3000	2500	1100	3000	2500	1000	3000	2000
>=25	1500	3500	2500	1250	3500	2500	1100	3000	2000
Ø100-450	750	5000	-	600	4500	-	450	3500	-

RAW MAT.:	1	Quantity:	Material Number:	Material Description:	Length (mm):	Width (mm):
Drawn:	EP	Weight (kg):	61	General tolerance: ISO 2768- mK		
Date:	13-10-2023	Drawn according: ISO286; ISO1101; ISO2553			Status: Released	
Spare part:	False	Customer reference number:			Document number: E0161874 Doc.Rev: A	
Quick search:	FX-1500	Description: HPL-RA-1500-152x485-120-FE			Part number: E0161874 Rev: A	

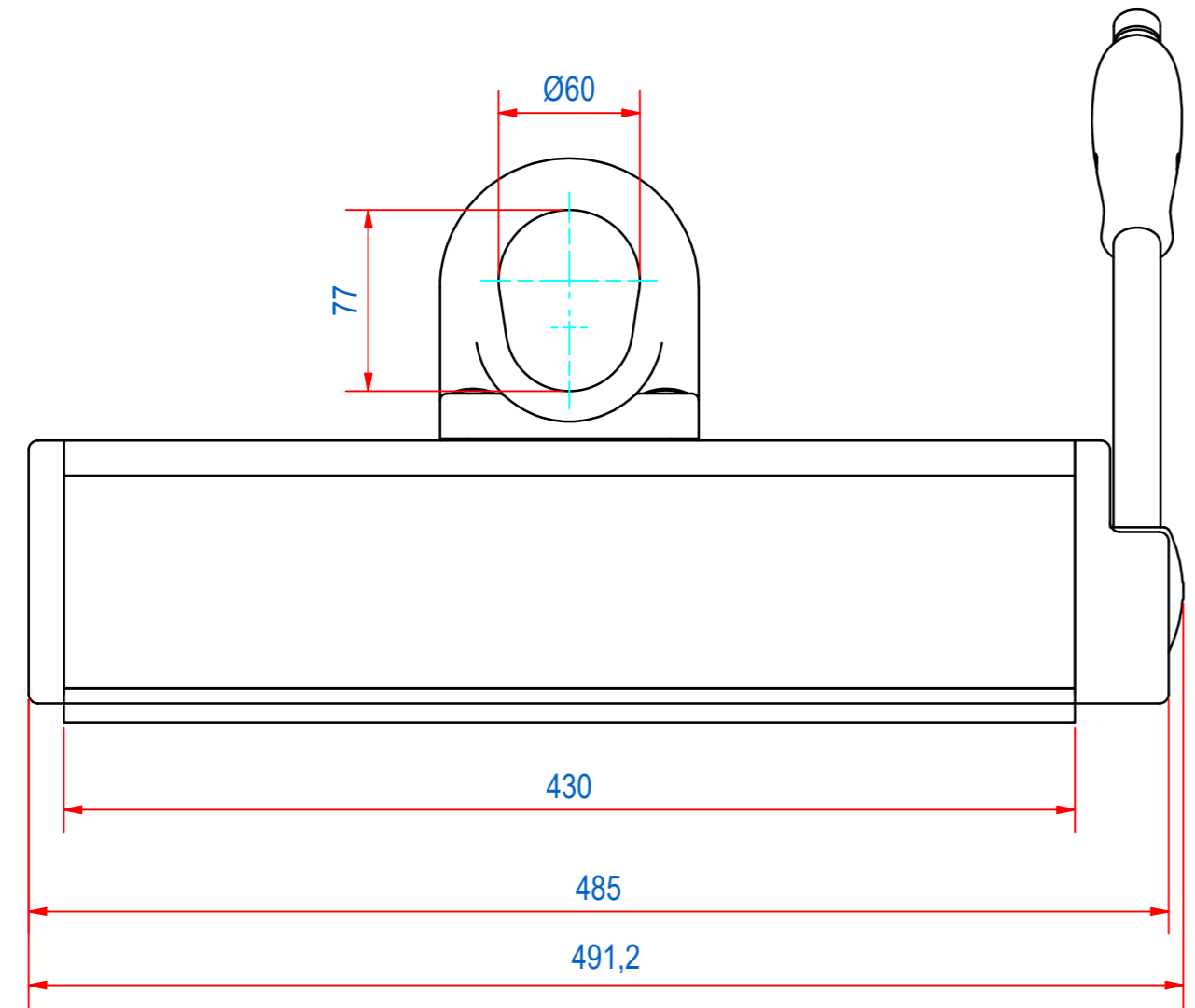
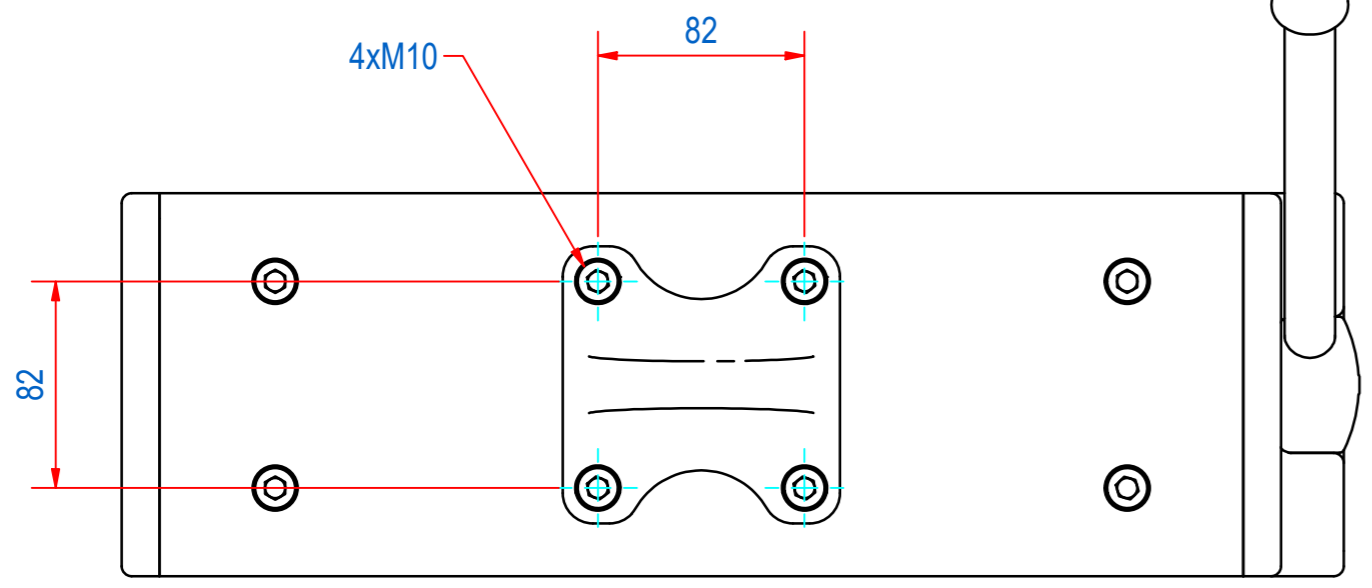
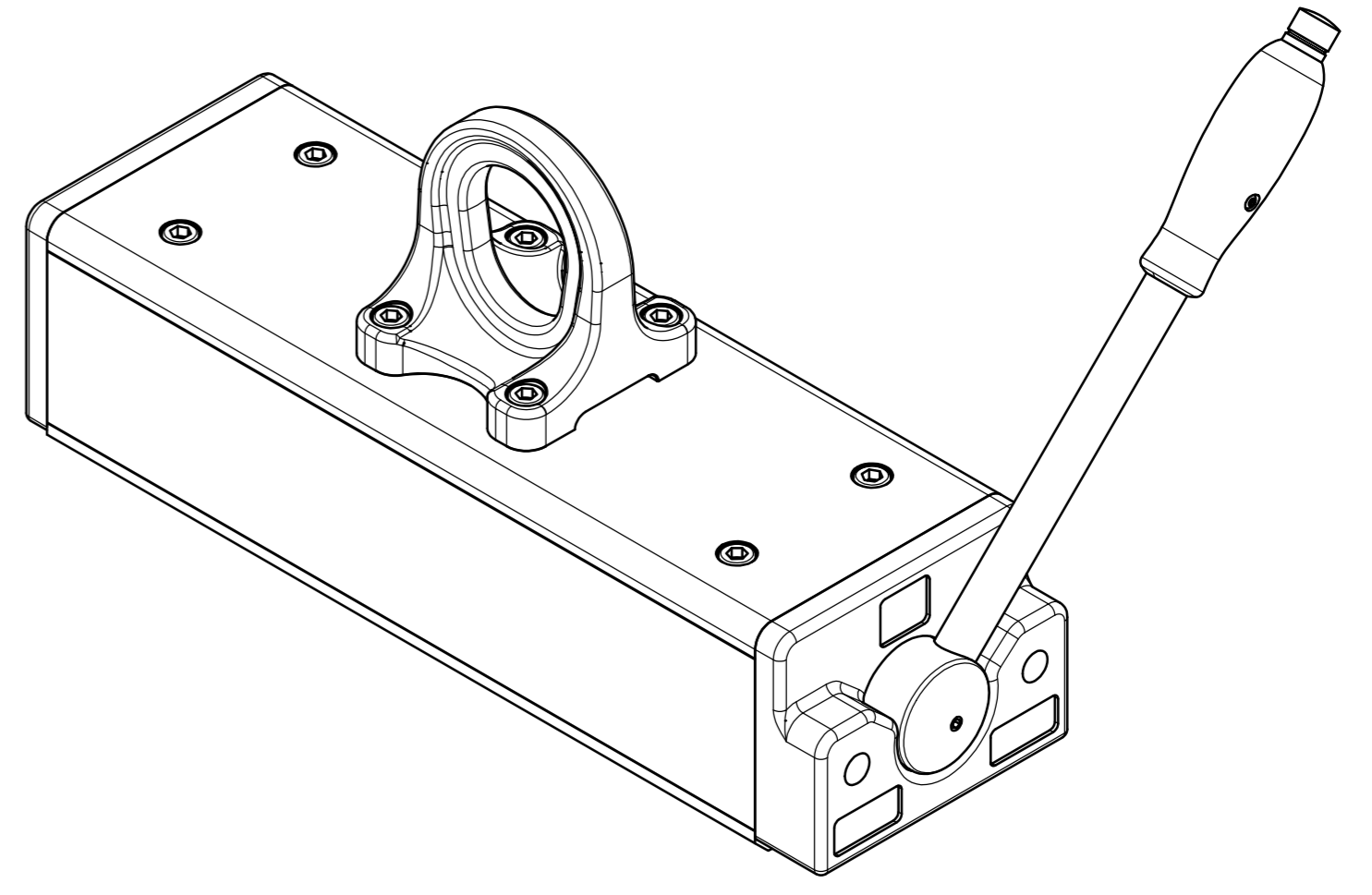

© All rights reserved. Reproduction is not permitted without written permission of GOUDSMIT Magnetic Systems BV