

DOC.NR.	REV	DATE	BY	DESCRIPTION
E0161880	-	16-10-2024	EP	ORIGINAL DRAWING
E0161880	A	16-10-2024	EP	ADDED CORRECT WEIGH

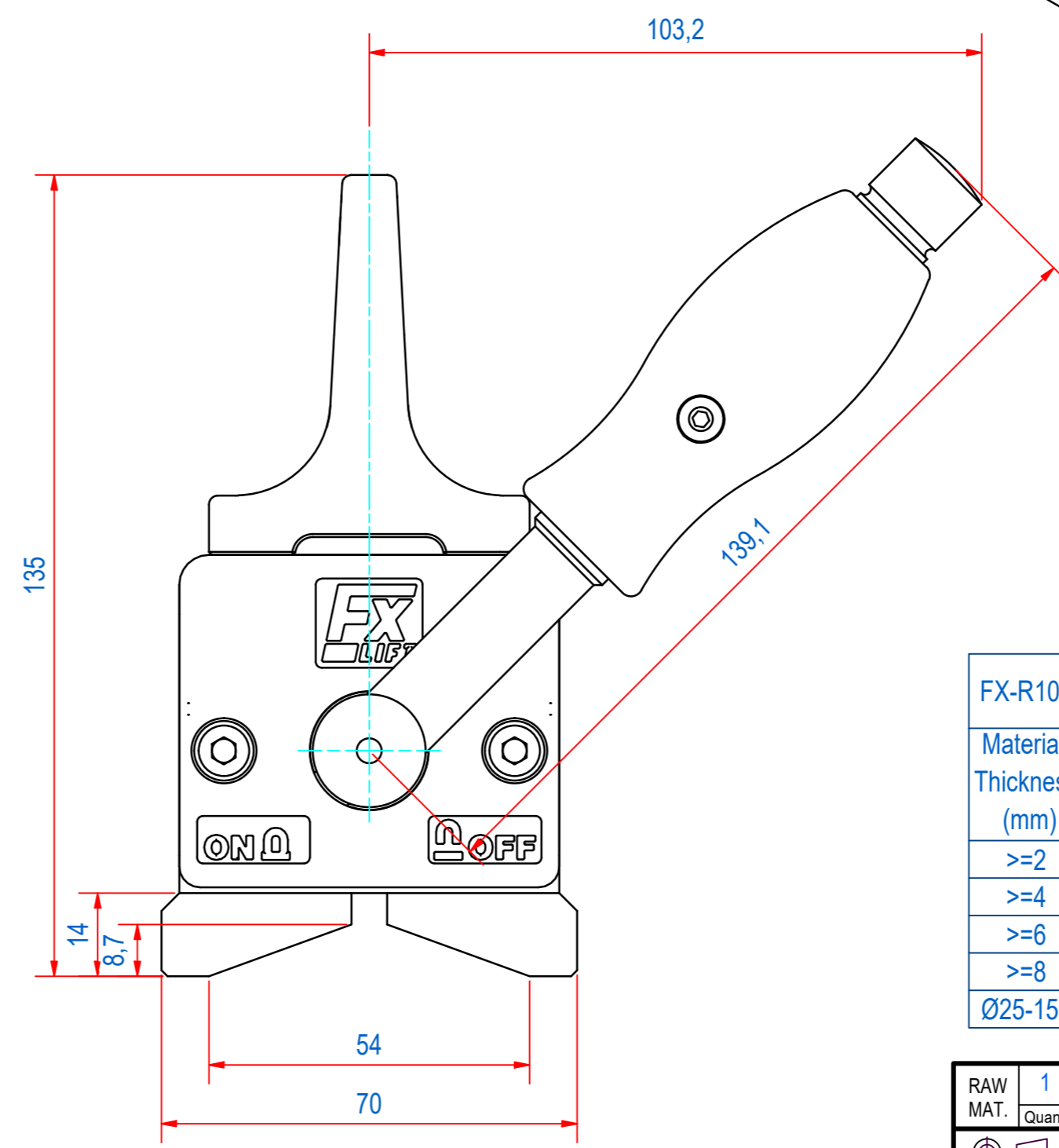

FX-R100	Air gap <0,1mm			Air gap 0,1-0,3mm			Air gap 0,3-0,5mm		
Material Thickness (mm)	Max. Load (kg)	Max. L (mm)	Max. B (mm)	Max. Load (kg)	Max. L (mm)	Max. B (mm)	Max. Load (kg)	Max. L (mm)	Max. B (mm)
>=2	25	800	800	12	800	800	10	800	800
>=4	50	1500	1000	40	1500	1000	30	1200	1000
>=6	70	1500	1000	60	1500	1000	45	1200	1000
>=8	100	1500	1000	75	1500	1000	60	1200	1000
Ø25-150	100	2000	-	75	2000	-	60	1500	-

RAW MAT.	Quantity	Material Number	Material Description	Length (mm)	Width (mm)
1					
Sheet:	A2	Extra info:		General tolerance: ISO 2768- mK	
Drawn:	EP	Weight (kg):	4	Drawn according: ISO286; ISO1101; ISO2553	
Date:	13-10-2023	Status: Released		Customer reference number:	
Spare part:	False	Document number: E0161880		Doc.Rev: A	
Quick search:	FX-R225	© All rights reserved. Reproduction is not permitted without written permission of GOUDSMIT Magnetic Systems BV		Part number: E0161880	
Description:	HPL-RA-0100-070x161-068-FE			Rev: A	

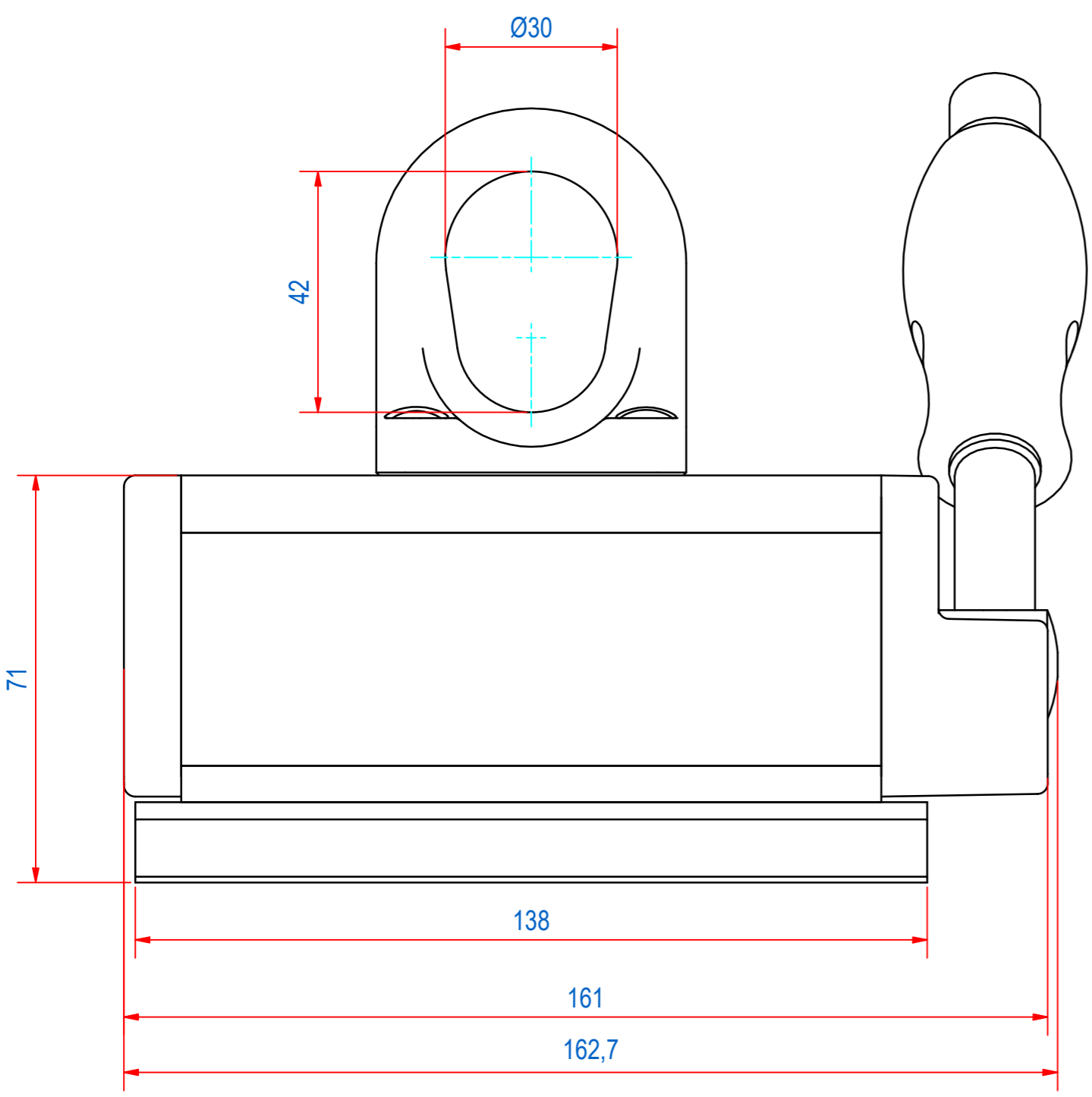
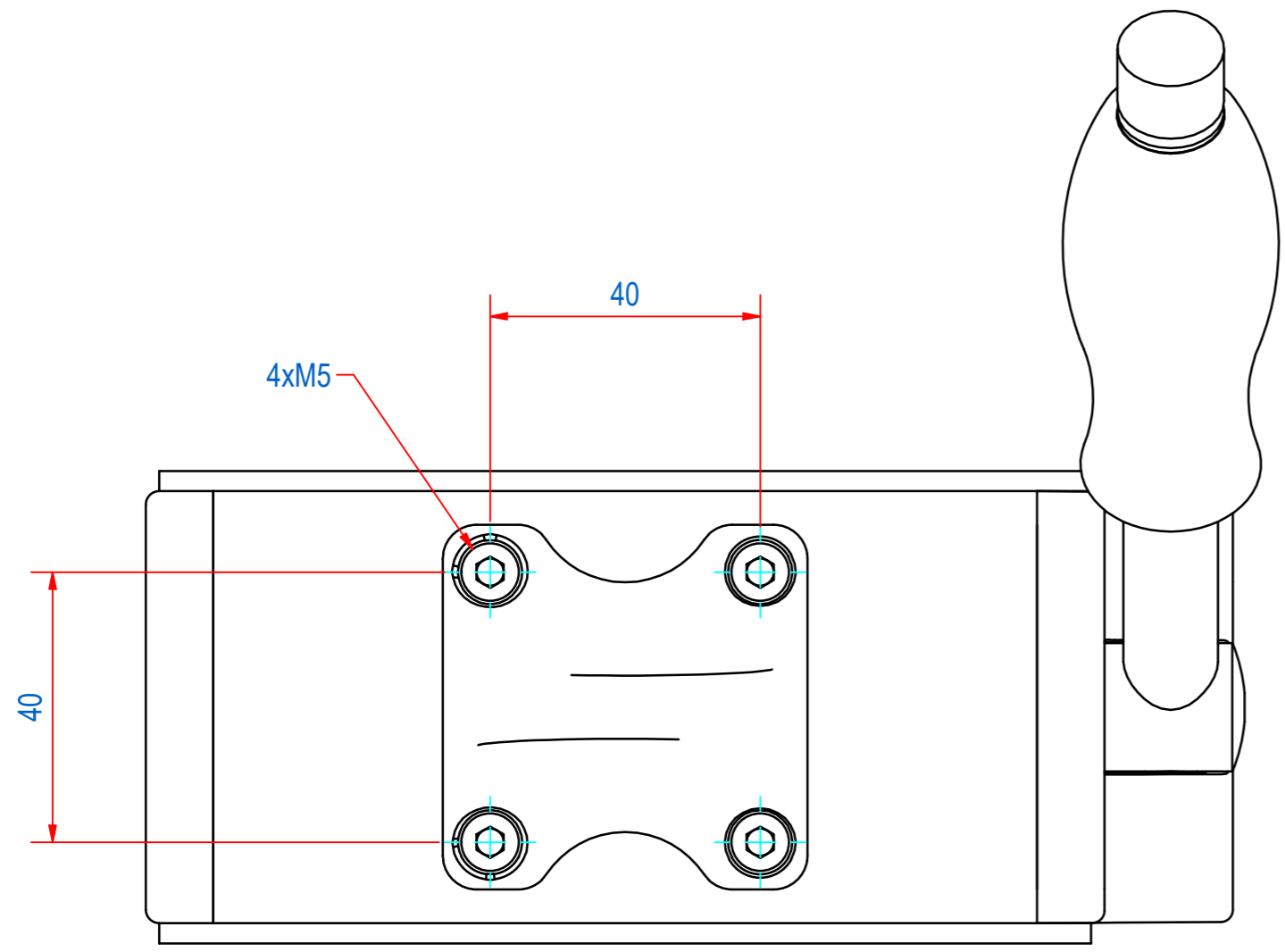
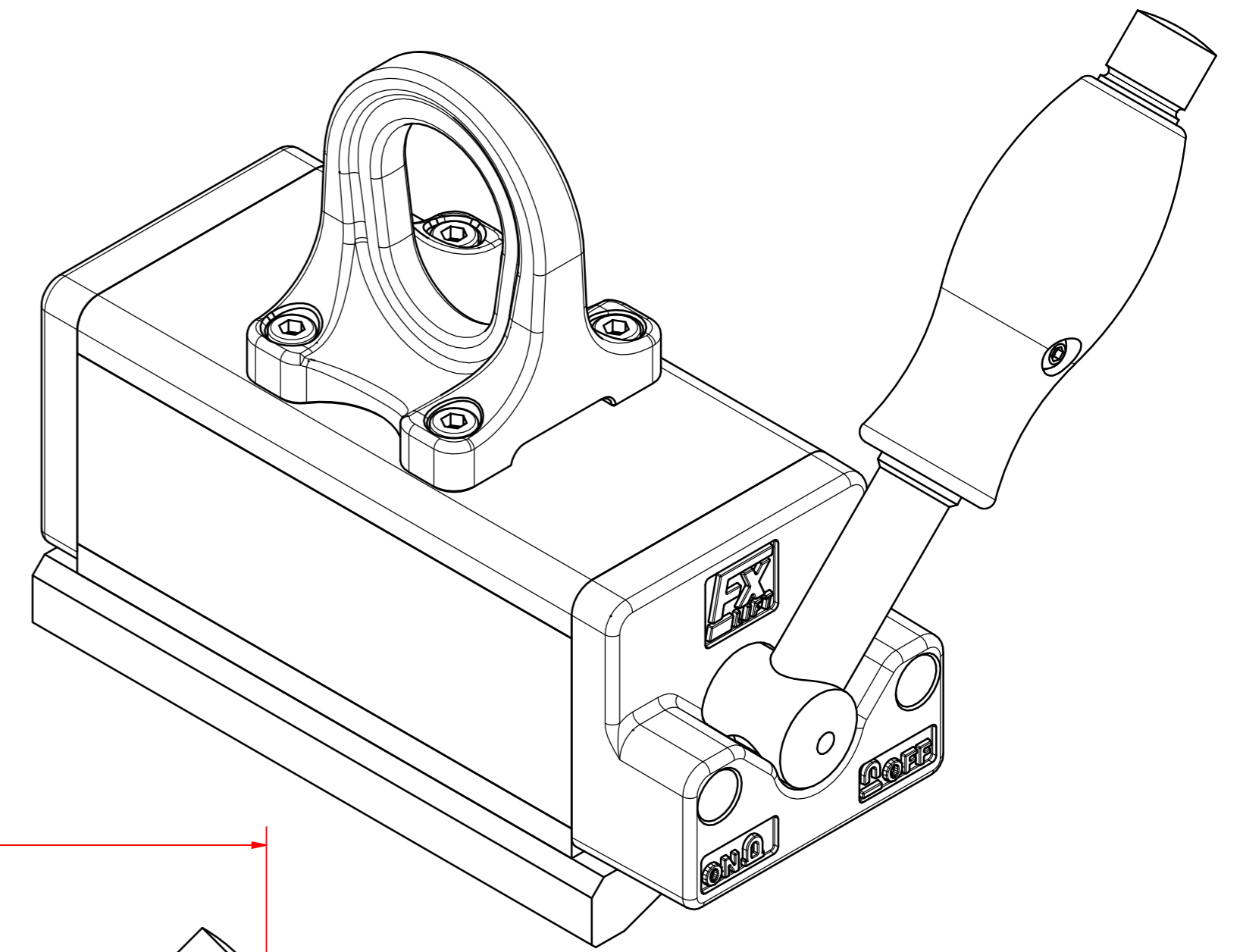