

DOC.NR.	REV	DATE	BY	DESCRIPTION
E0161882	-	16-10-2024	EP	ORIGINAL DRAWING
E0161882	A	16-10-2024	EP	ADDED CORRECT WEIGH

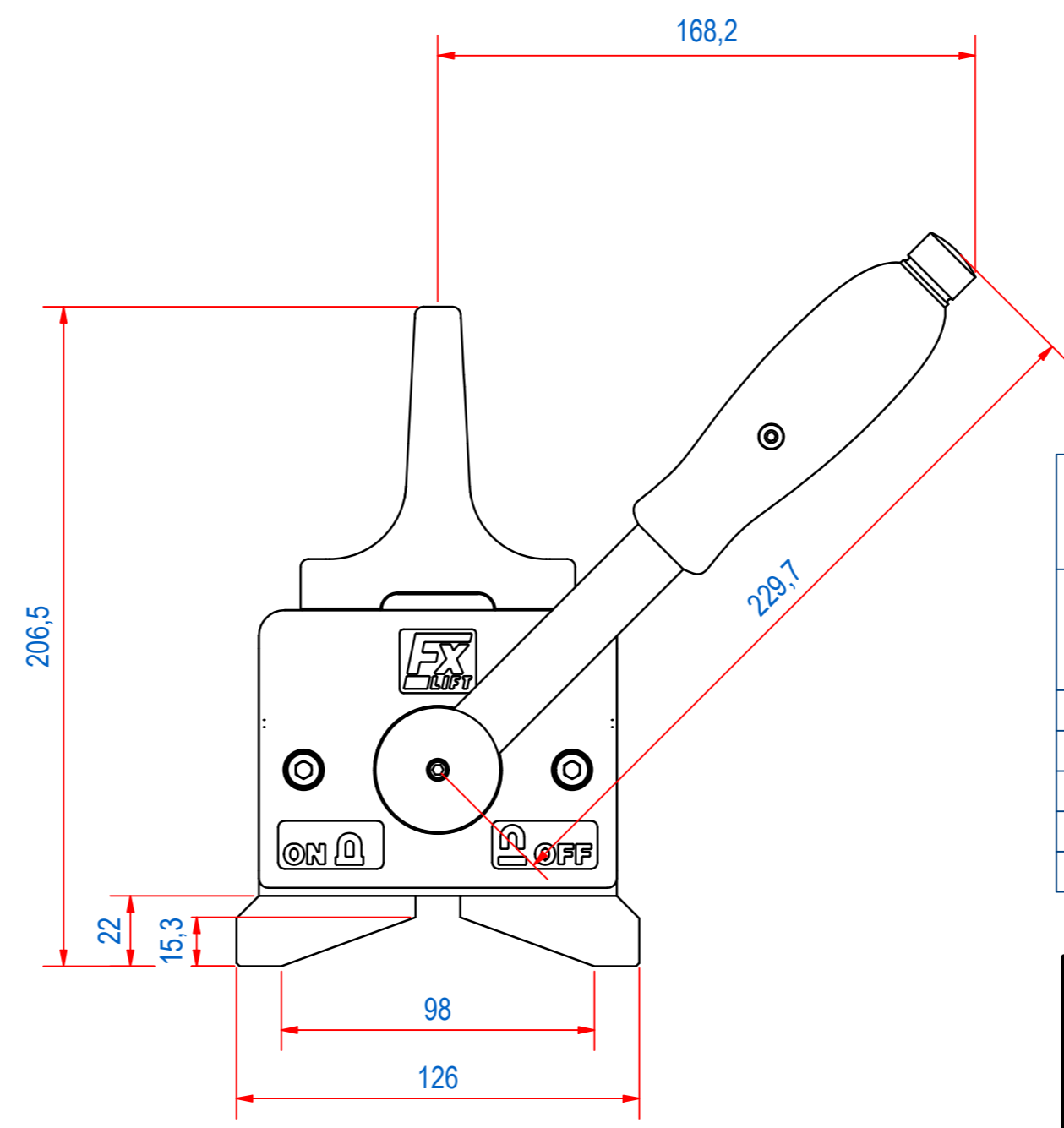

FX-R450	Air gap <0,2mm			Air gap 0,2-0,3mm			Air gap 0,3-0,6mm		
Material Thickness (mm)	Max. Load (kg)	Max. L (mm)	Max. B (mm)	Max. Load (kg)	Max. L (mm)	Max. B (mm)	Max. Load (kg)	Max. L (mm)	Max. B (mm)
>=6	150	1800	1500	120	1800	1000	100	1500	1250
>=10	300	2250	1500	250	2250	1250	210	2000	1250
>=15	400	2500	1500	350	2500	1250	300	2000	1250
>=20	450	3000	1500	400	3000	1250	350	2500	1250
Ø50-270	450	4000	-	375	3500	-	280	3000	-

RAW MAT.:	1	Quantity:	Material Number:	Material Description:	Length (mm):	Width (mm):
Drawn:	EP	Weight (kg):	22	General tolerance: ISO 2768- mK		
Date:	13-10-2023	Drawn according: ISO286; ISO1101; ISO2553			Status: Released	
Spare part:	False	Customer reference number:			Document number: E0161882 Doc.Rev: A	
Quick search:	FX-R450	Description: HPL-RA-0450-126x288-112-FE			Part number: E0161882 Rev: A	

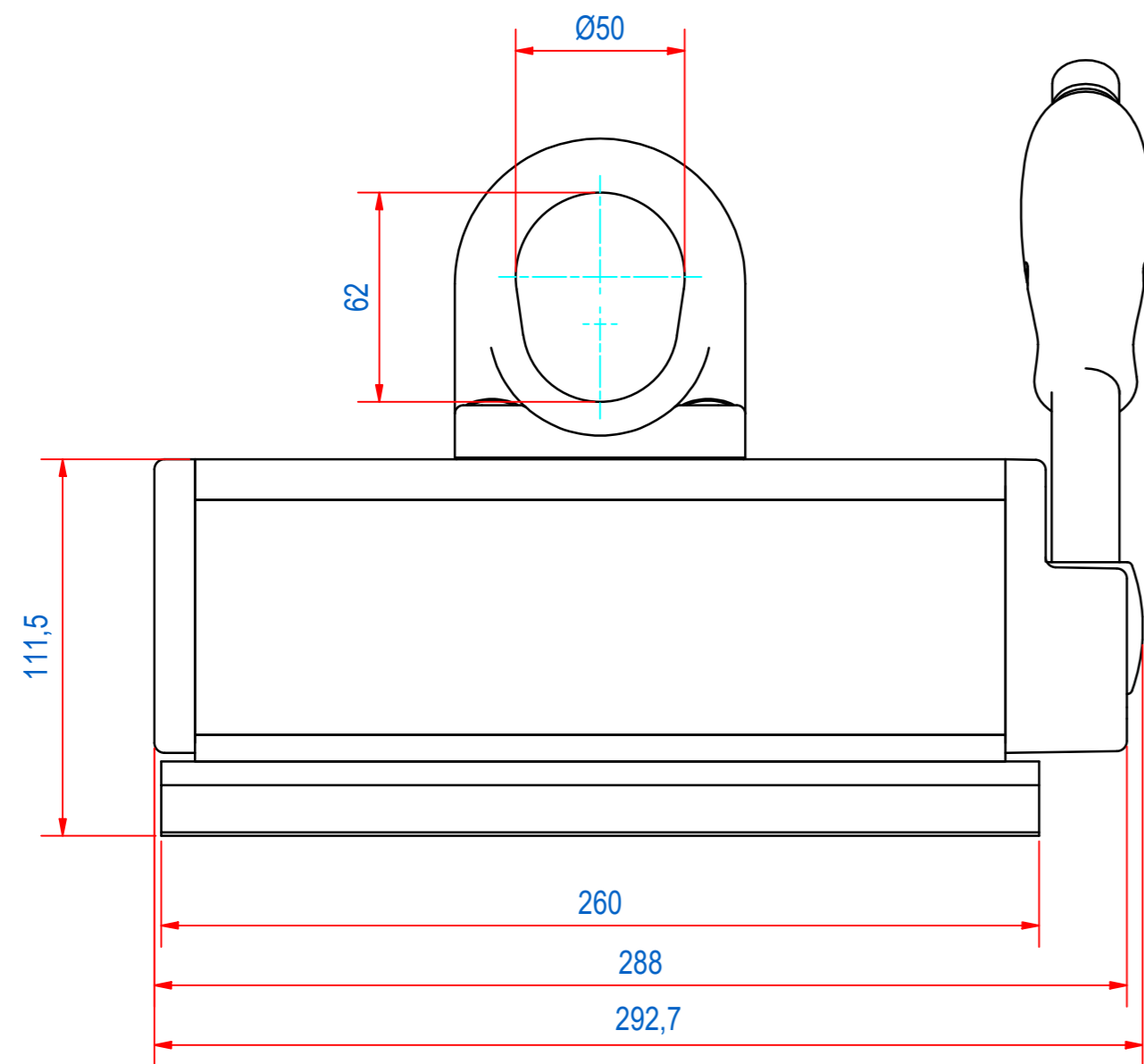
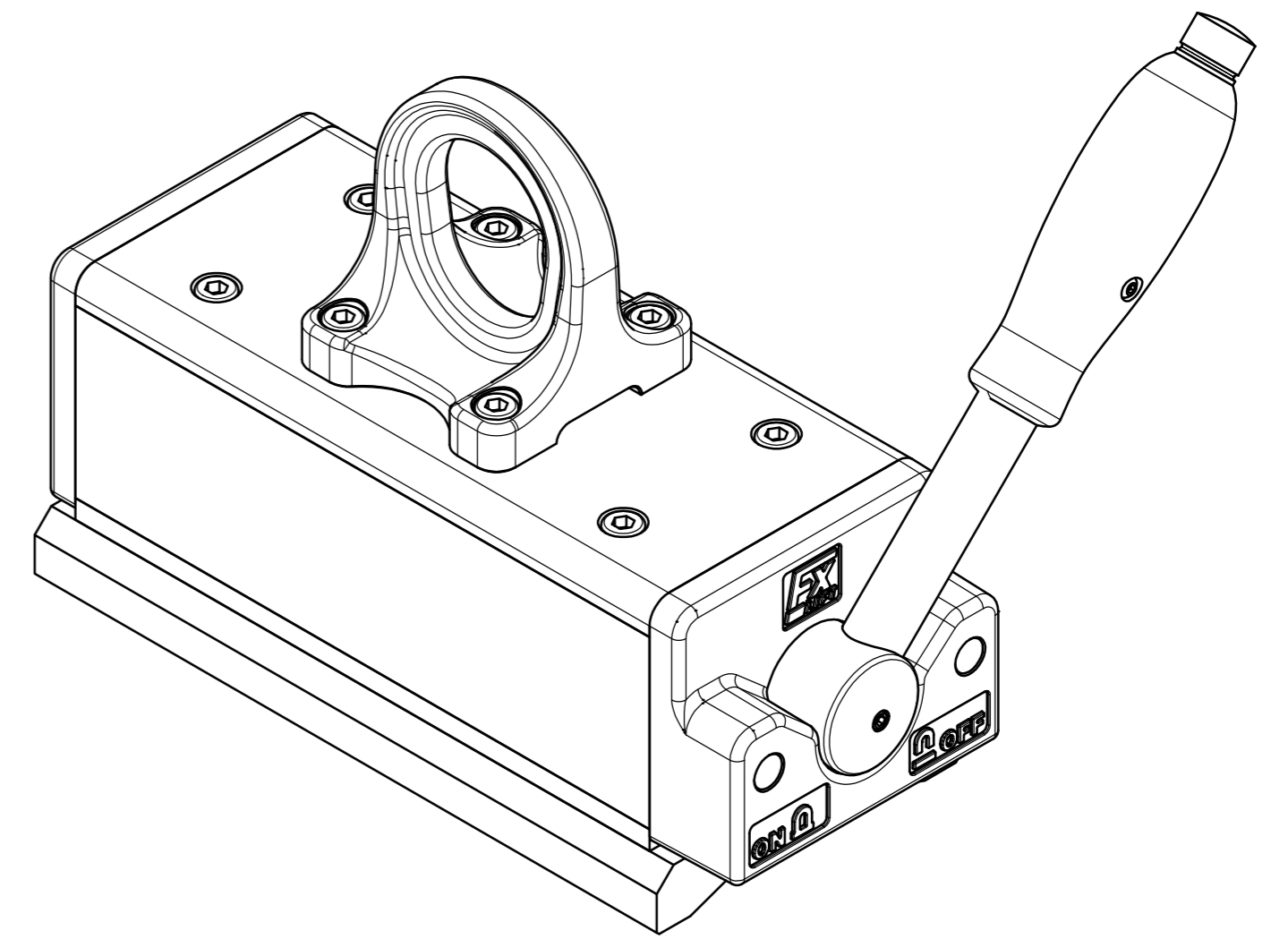
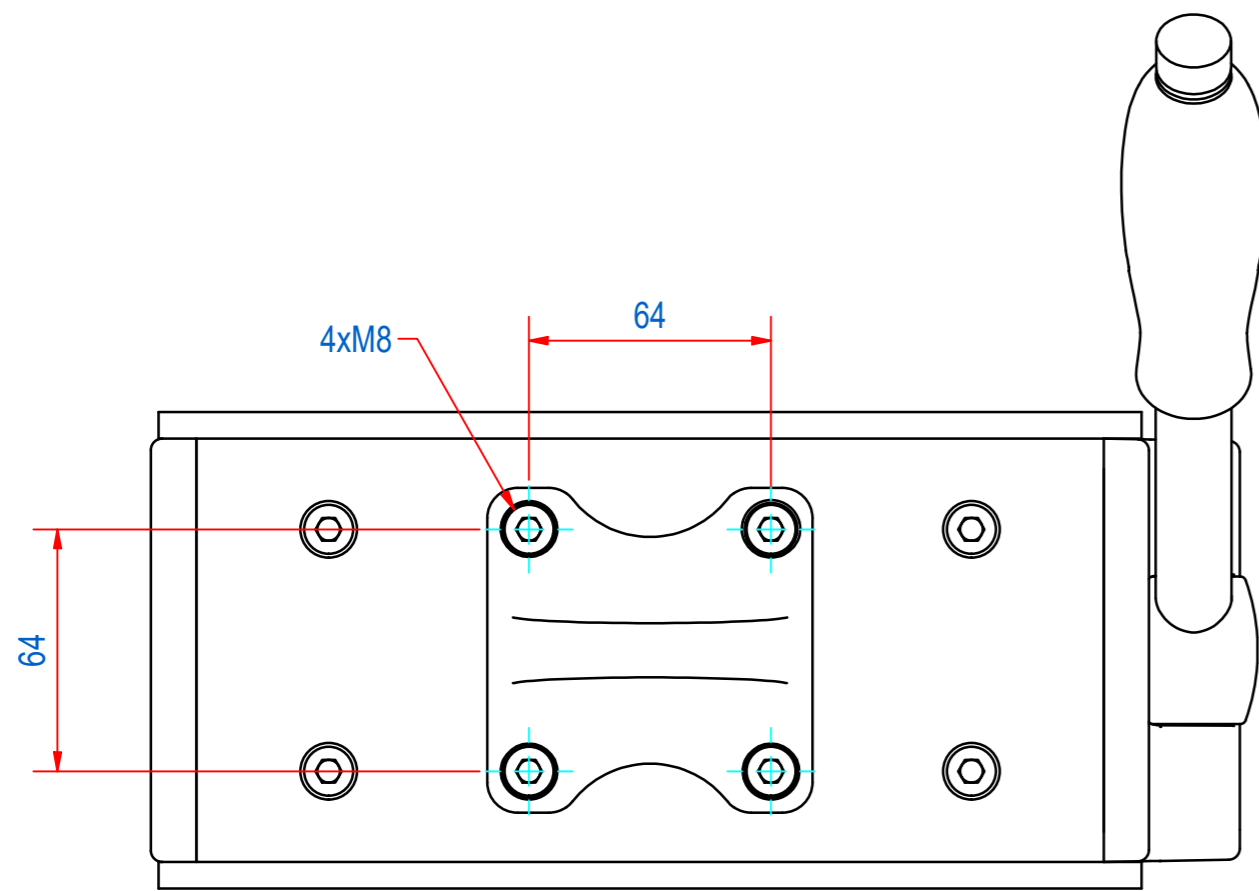

© All rights reserved. Reproduction is not permitted without written permission of GOUDSMIT Magnetic Systems BV