

REV	DATE	BY	DESCRIPTION
-	9-11-2023	AvD	REFERENCE DRAWING SRCD320018
A	29-1-2024	CR	MC-C SOURCE CODE ADDED, REFERENCE DIMENSIONS ADDED

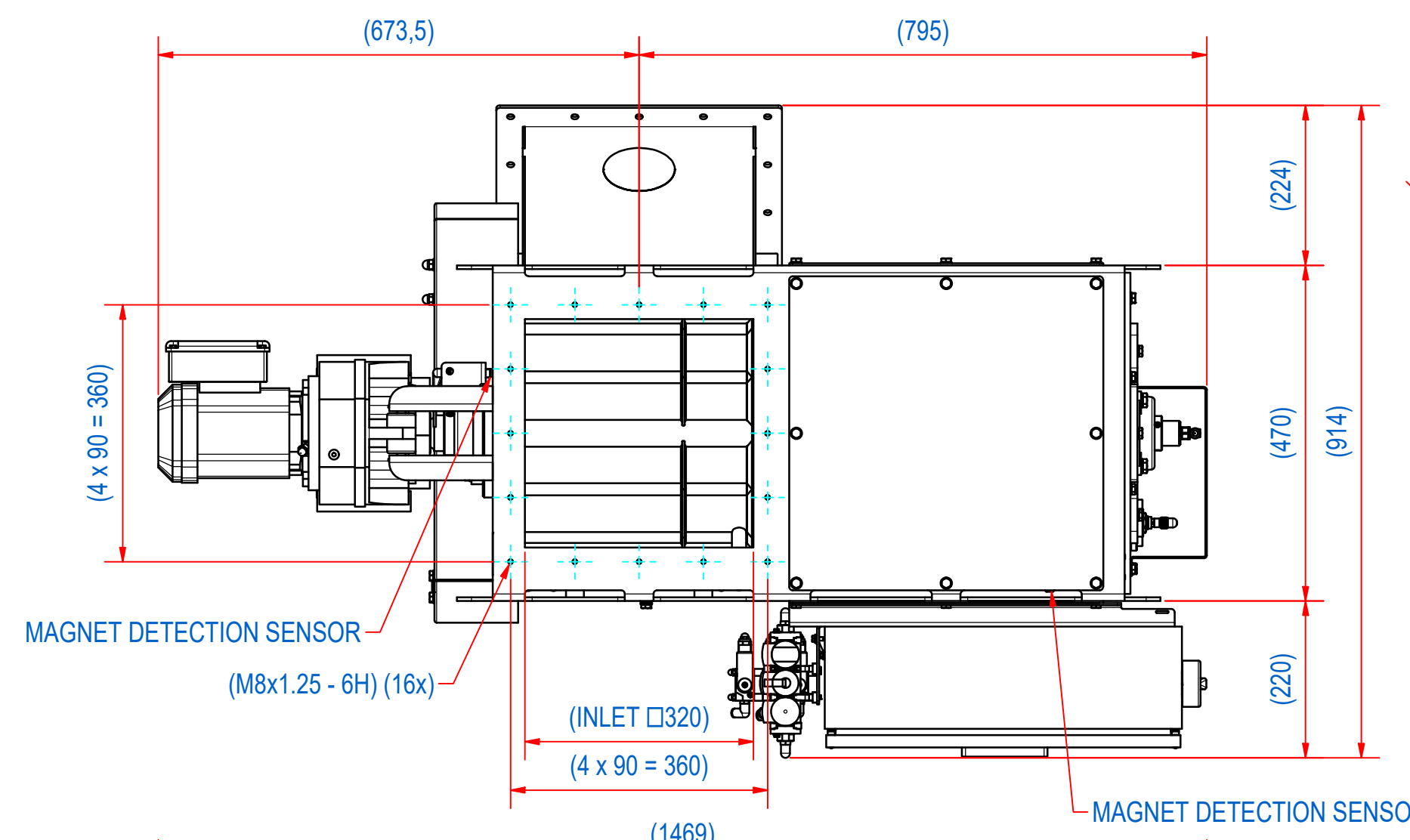

B-B (1:4)

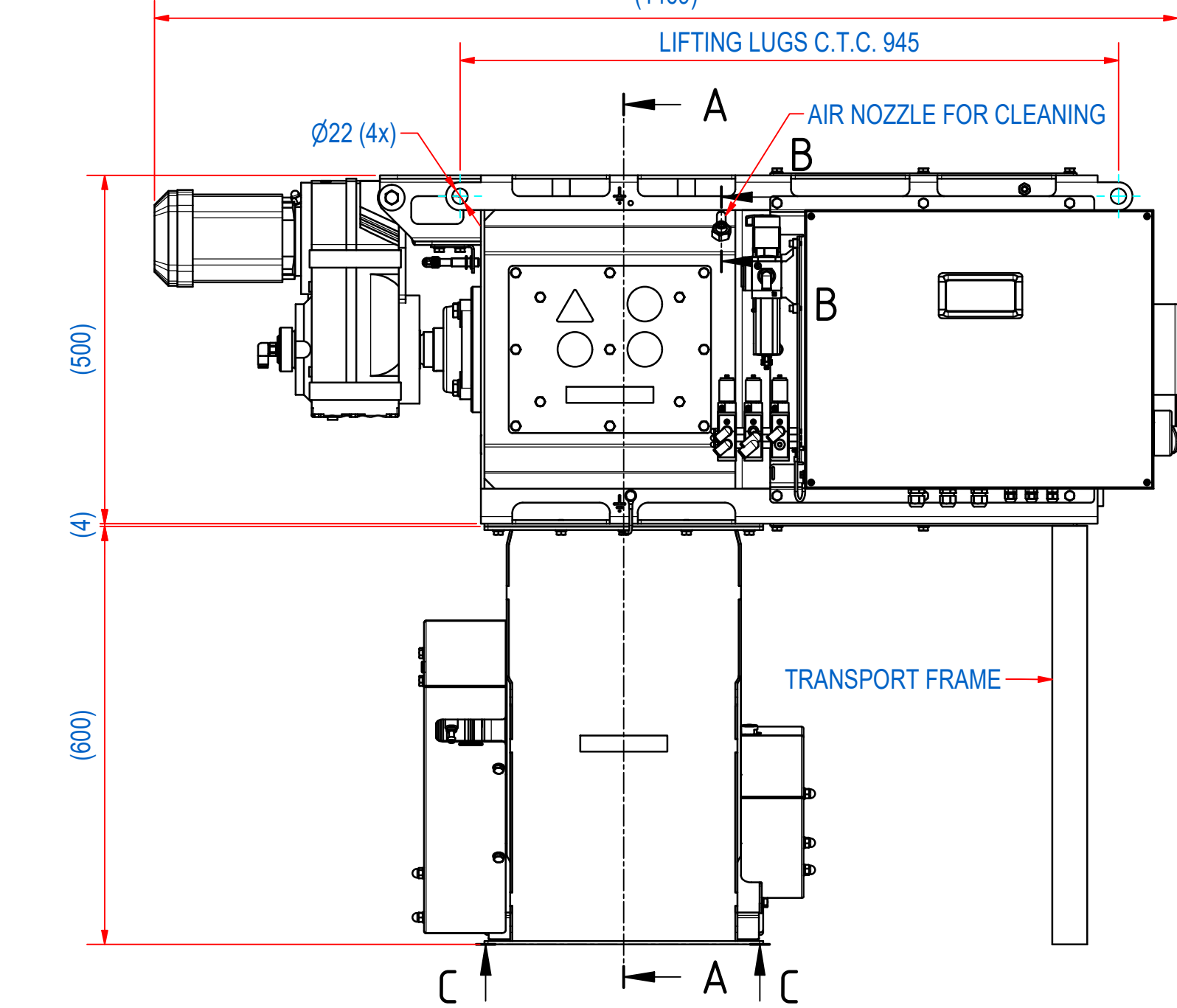
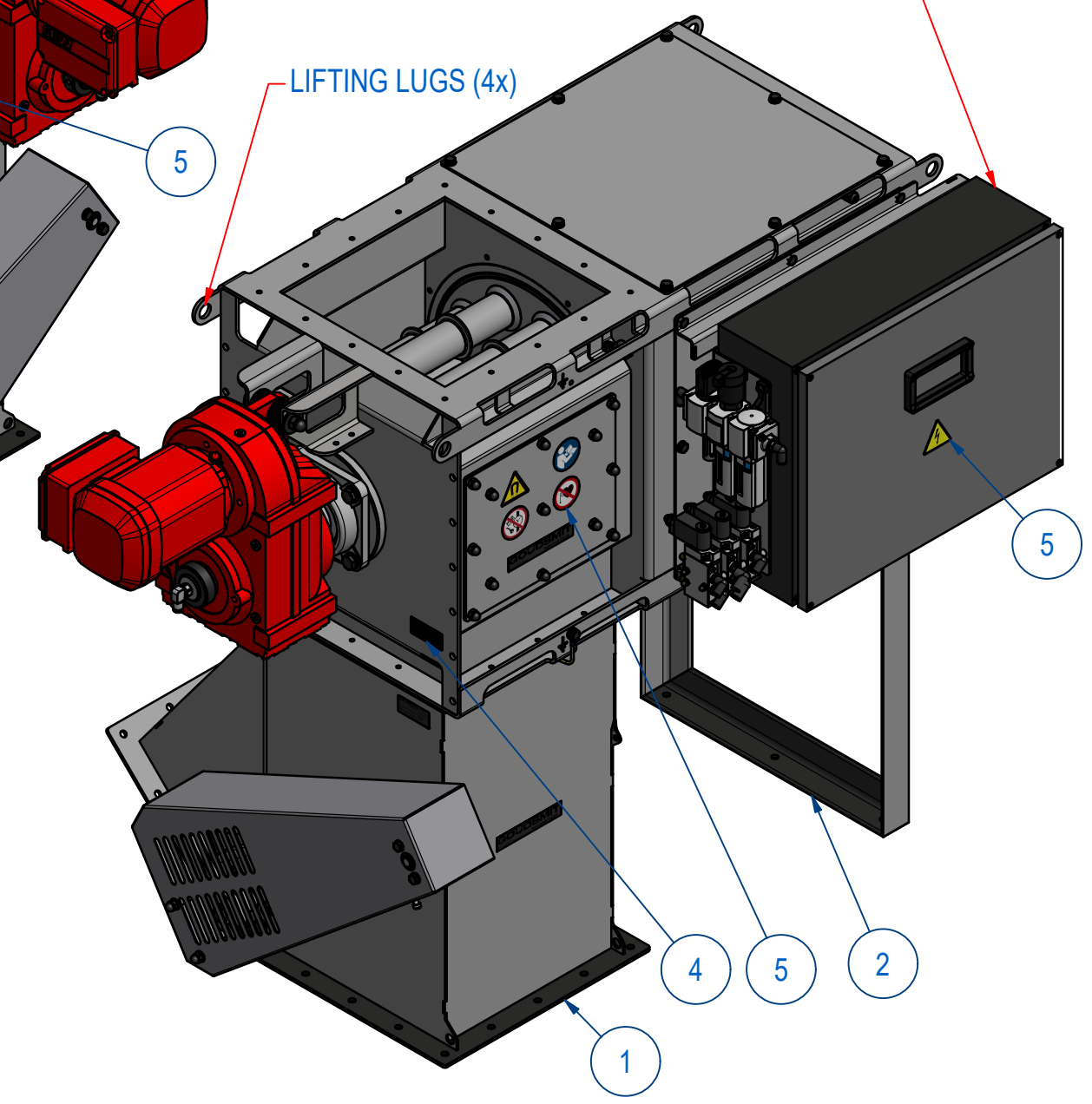
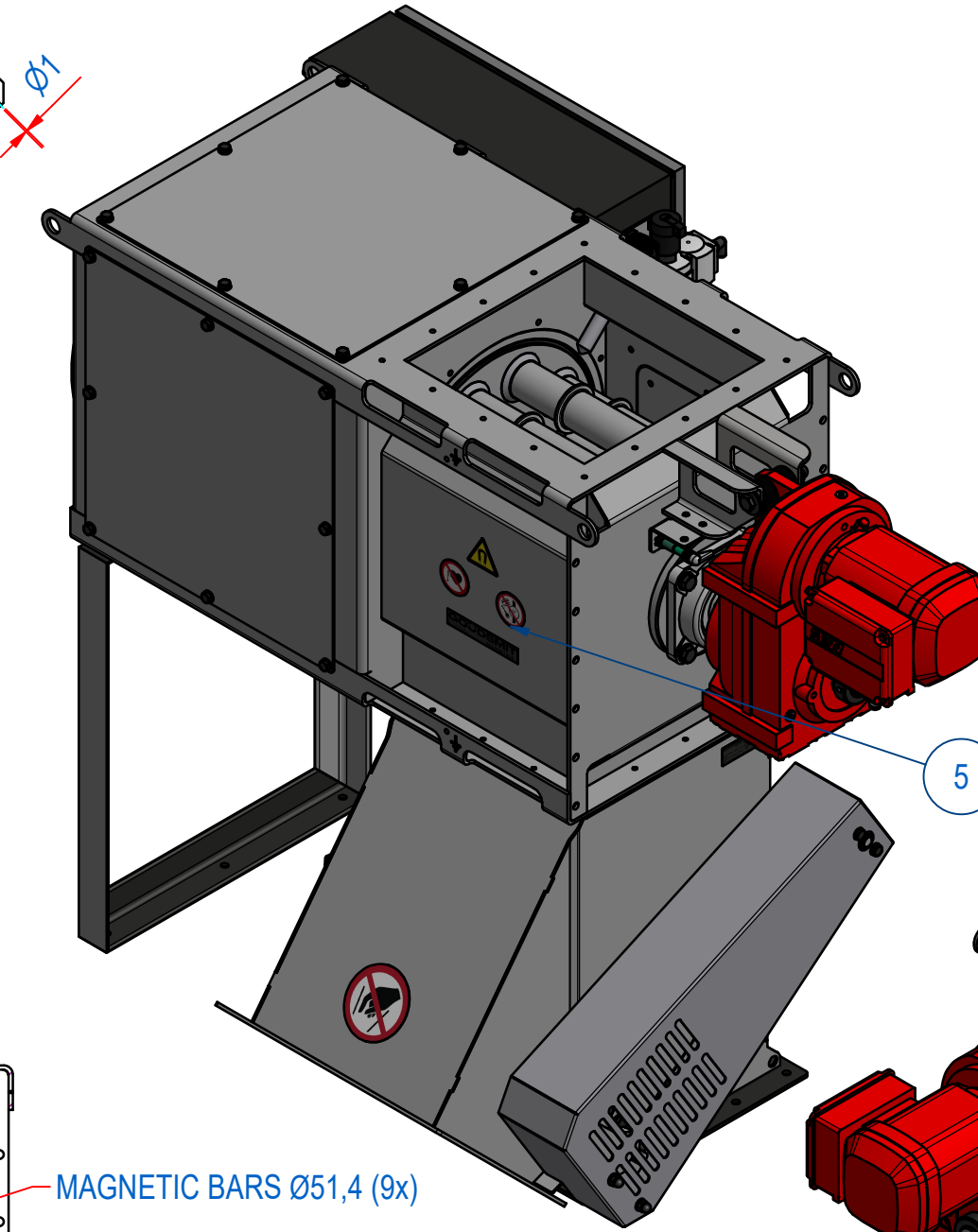
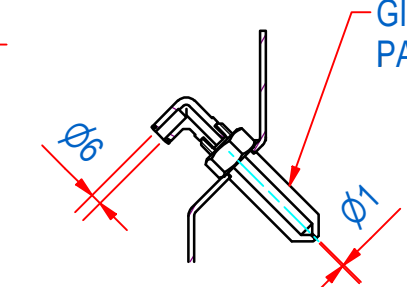

A-A

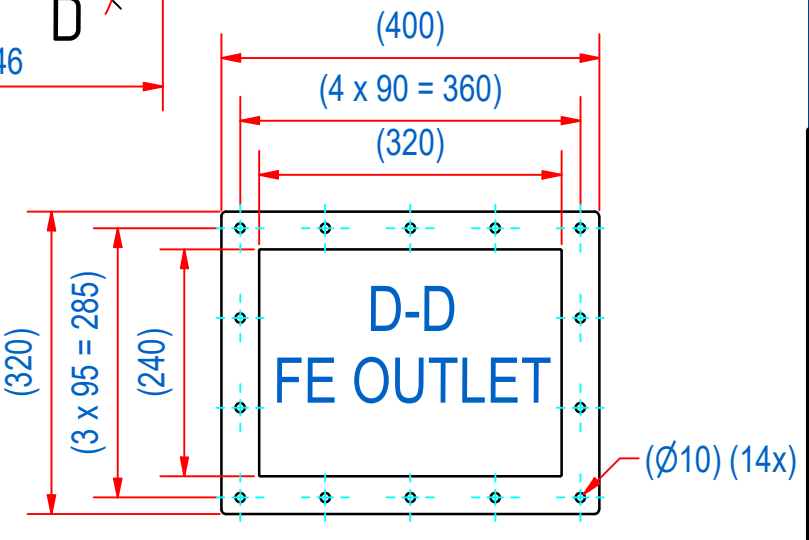
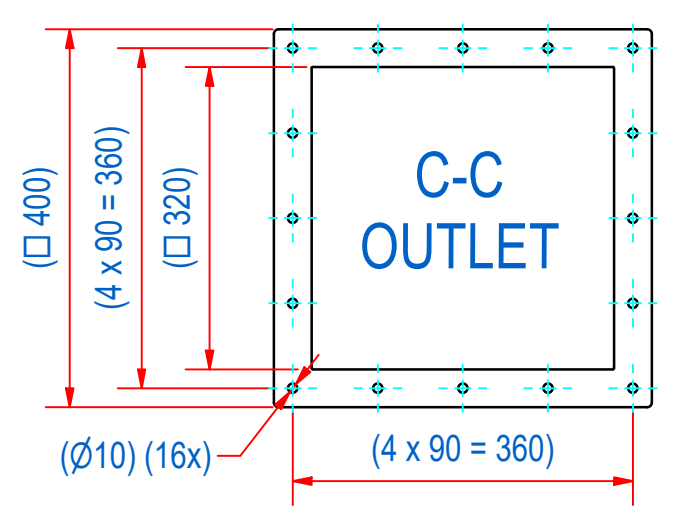
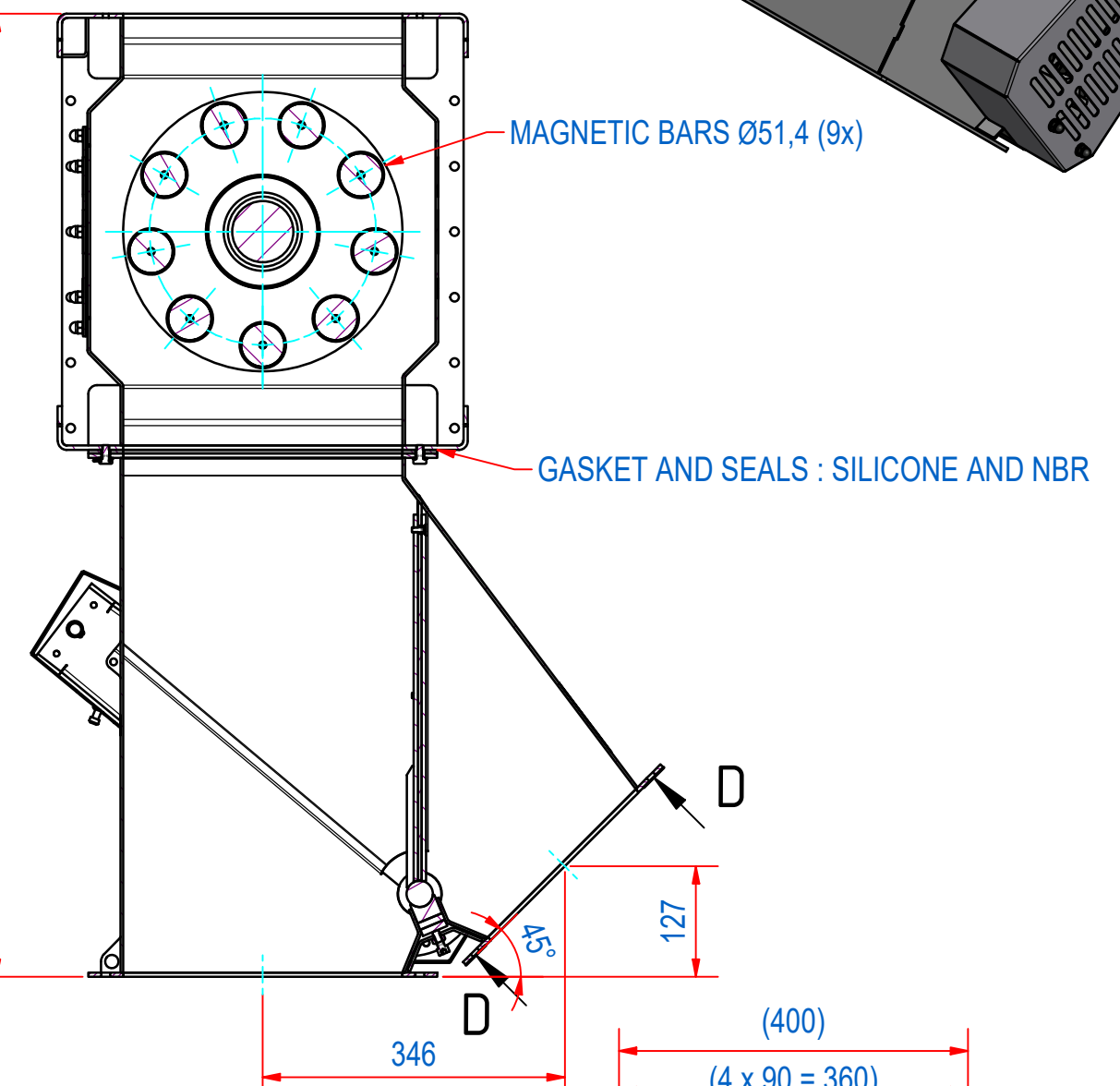

VALVE BOX CAN BE MOUNTED IN FOUR DIRECTIONS (STANDARD AS ON DRAWING)

ITEM	QTY	PART NUMBER	DESCRIPTION	Dimensions
5	1	E0154563	SRCD-000 WARNING STICKERS	
4	1	E0083890	SRCD ATEX II 3D Ex h IIIC T130°C Dc	
3	1	E0025799	SRCD/VALVE PNEUMATIC SCHEMA	
2	1	E0154211	SRCD-3232 TRANSPORT FRAME	
1	1	E0162463	SRCD-3232-09U-ES-V-S ASSY	

RAW MAT.	Quantity	Material Number	Material Description	Length (mm)	Width (mm)
1	1				

Sheet: A2	Extra info: CLEANFLOW MAGNETIC ROTATING SIGMATEK CONTROL	General tolerance: ISO 2768 - mK
Drawn: AvD	Weight (kg): 300	Drawn according: ISO286; ISO1101; ISO2553
Date: 9-11-2023	Source: MC-C	Status: Standard
Spare part: False	Quick search: SRCD-3232	Customer reference number:
Description: SRCD-3232-09U-ES-F1H-V-S-B-F-S-X3	Document number: E0162462	Doc.Rev: A
	Part number: E0162462	Rev: A