

DOC.NR.	REV	DATE	BY	DESCRIPTION
E0164144	-	1-3-2024	AvD	ORIGINAL DRAWING

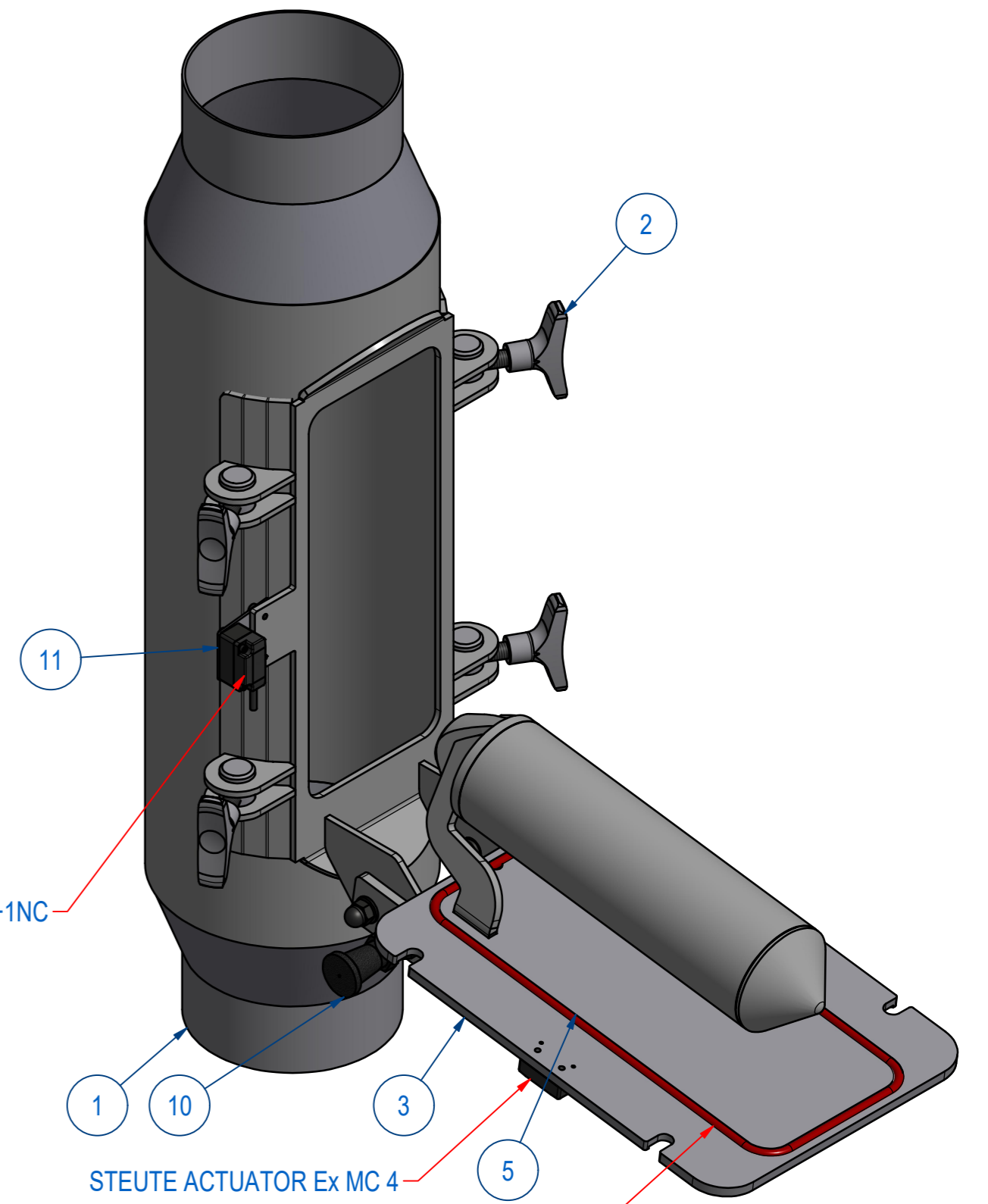
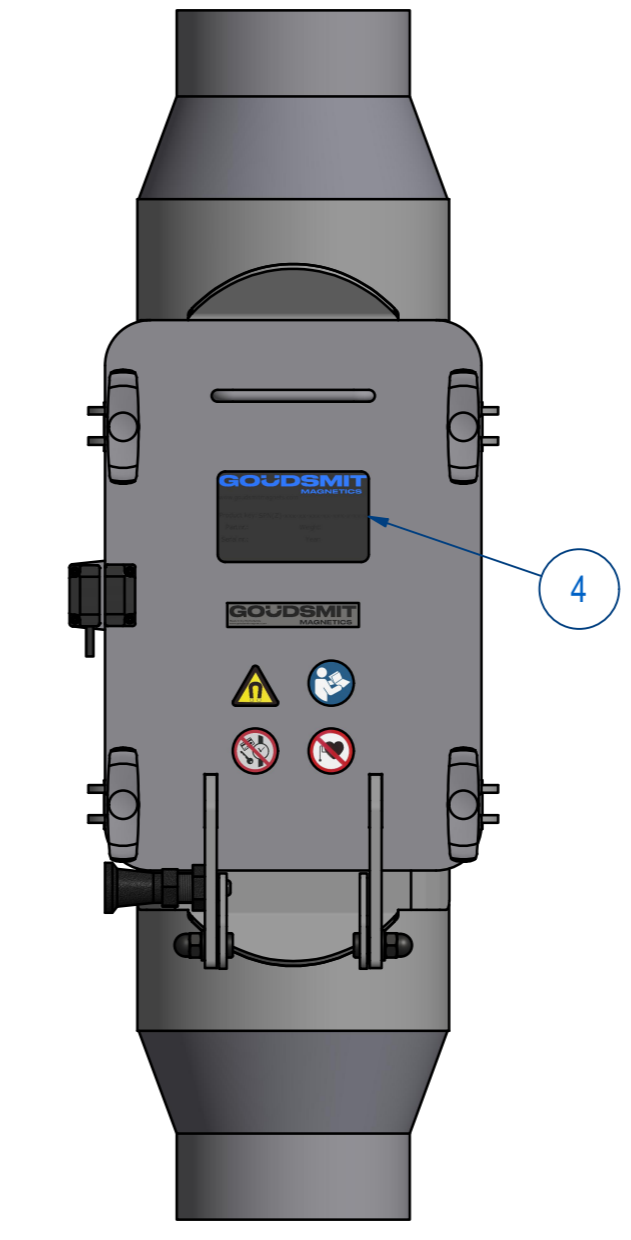
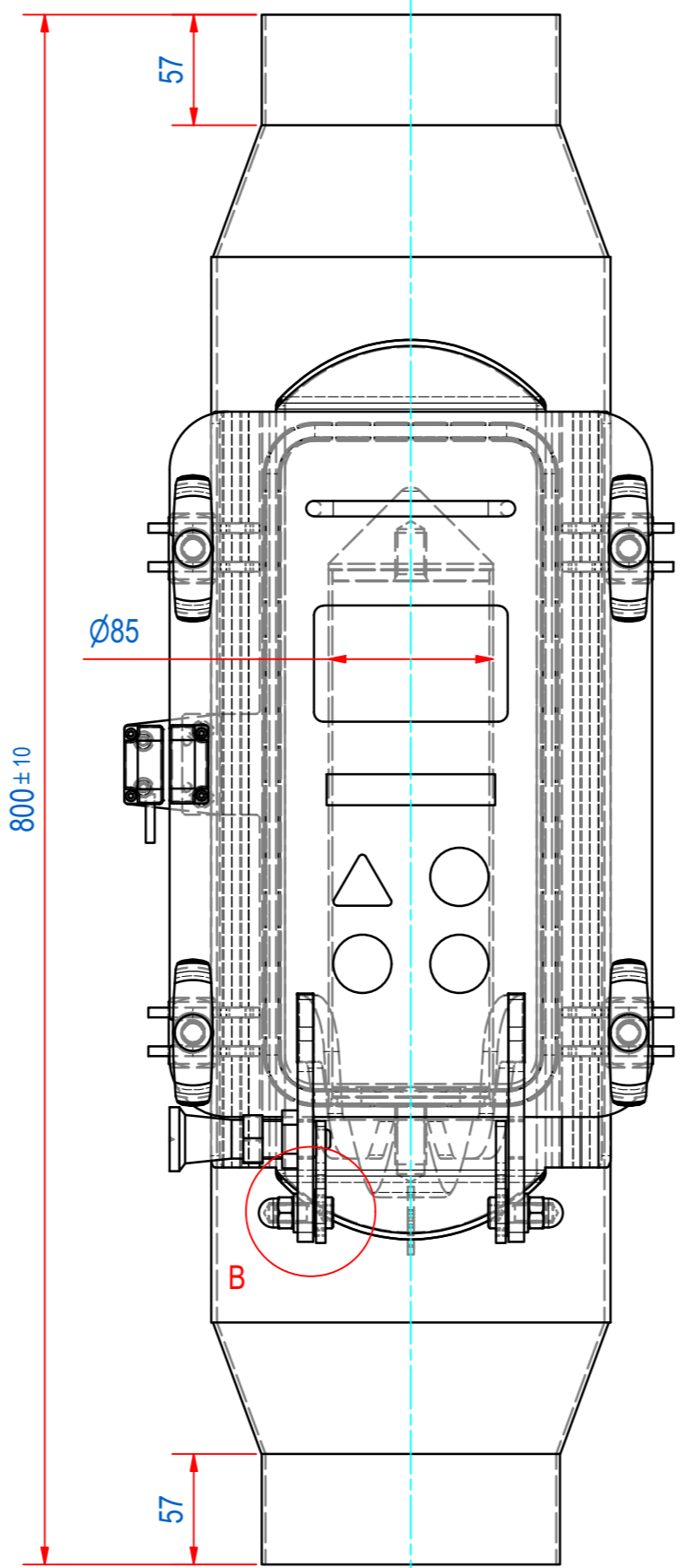
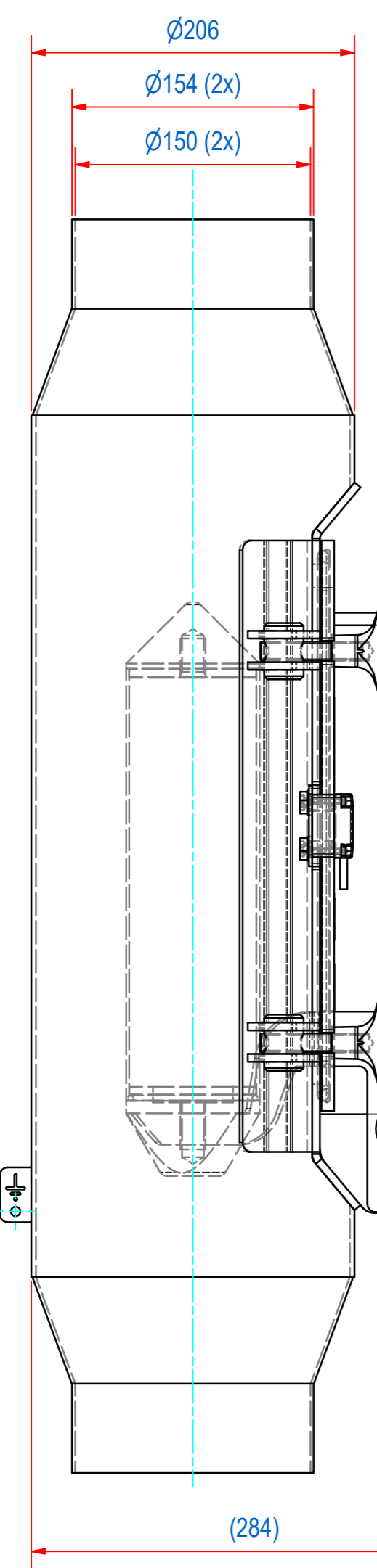
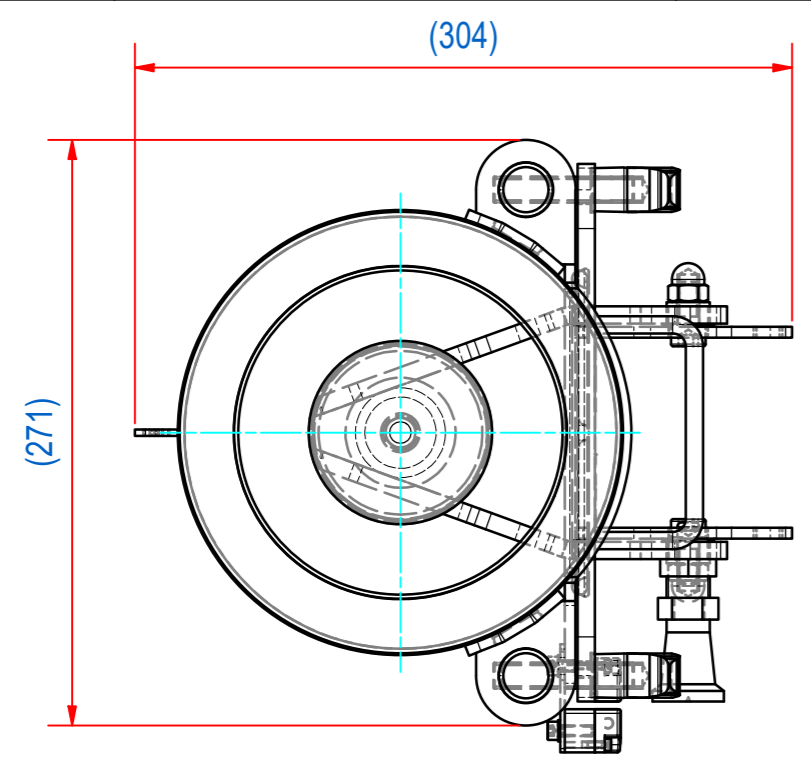

SAFETY SENSOR STEUTE Ex HS-Si-4 1NO+1NC

STEUTE ACTUATOR Ex MC 4

SEAL: O-RING SILICONE RED EC1935/2004

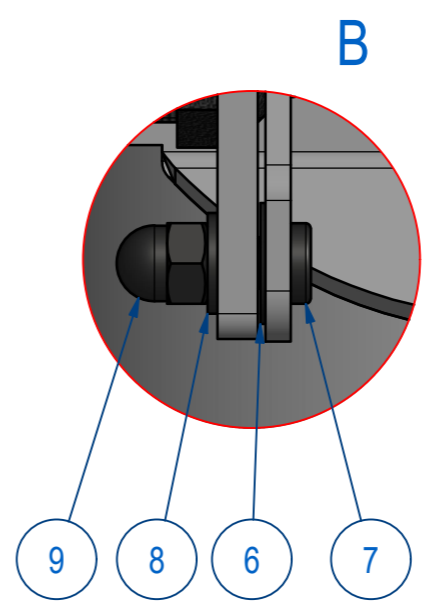

ITEM	QTY	PART NUMBER	DESCRIPTION	Dimensions
11	1	E0158569	SPN-000-STEUTE HS Si 4 Ex UNIT	
10	1	1005.90003	INDEXING PLUNGER D10 M20x1,5SS	
9	2	60.3300010	NUT, HEX CAP M10 - A4	M10
8	2	70.0300010	WASHER M10 - A4	M10
7	2	51.0310020	SCREW, HEX SH M10x20-A4	M10 x 20
6	2	15.0011618	BEARING IGLIDUR GFM-1618-06	
5	1	E0153787	SPN-S-O-RING SILIC. RED	
4	1	E0153785	SPN-000-TYPE PLATE+STICKERS	
3	1	E0153700	SPN-S-000-DOOR MAGNET INSERT	
2	4	E0153767	SPN-000 TOGGLE M12	
1	1	E0164145	SPN-150-T1-HOUSE	

RAW MAT.	Quantity	Material Number	Material Description	Length (mm)	Width (mm)
⊕	1				

Sheet: A2	Extra info: Bullet Magnet	General tolerance: ISO 2768 - mK
Drawn: AvD	Weight (kg): 34	Drawn according: ISO286; ISO1101; ISO2553
Date: 27-2-2024		Status: Released
Spare part: False	Source:	Customer reference number:
Quick search: SPN-150		
Description: SPN-150-T1-01K-HT-F1m-S-T2-B	Document number: E0164144	Doc.Rev: -
	Part number: E0164144	Rev: -