

DOC.NR.	REV	DATE	BY	DESCRIPTION
E0164680	-	23-4-2024	LH	REFERENCE DRAWING E0104918
E0164680	A	10-10-2024	LH	PRODUCT KEY UPDATED

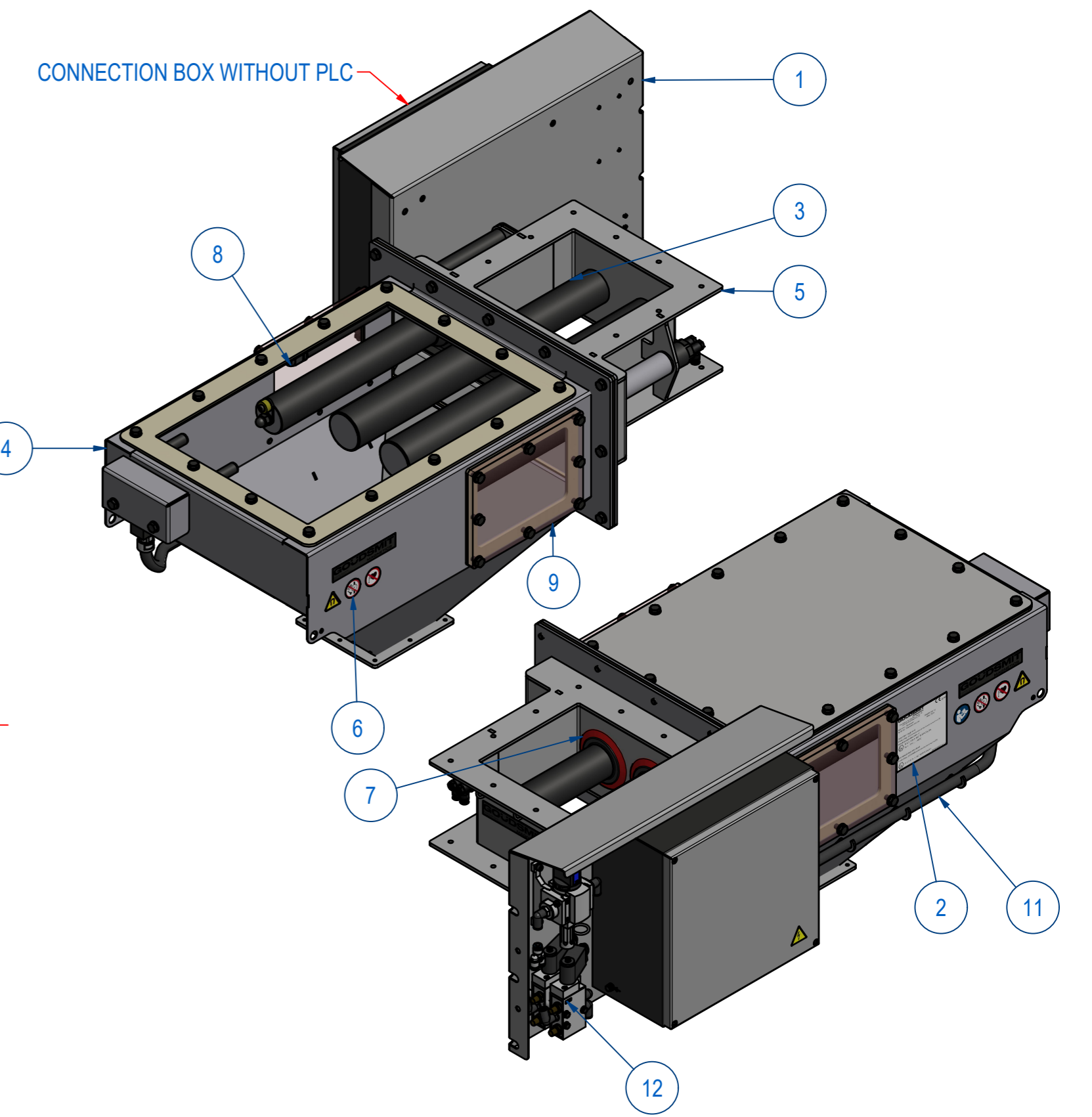
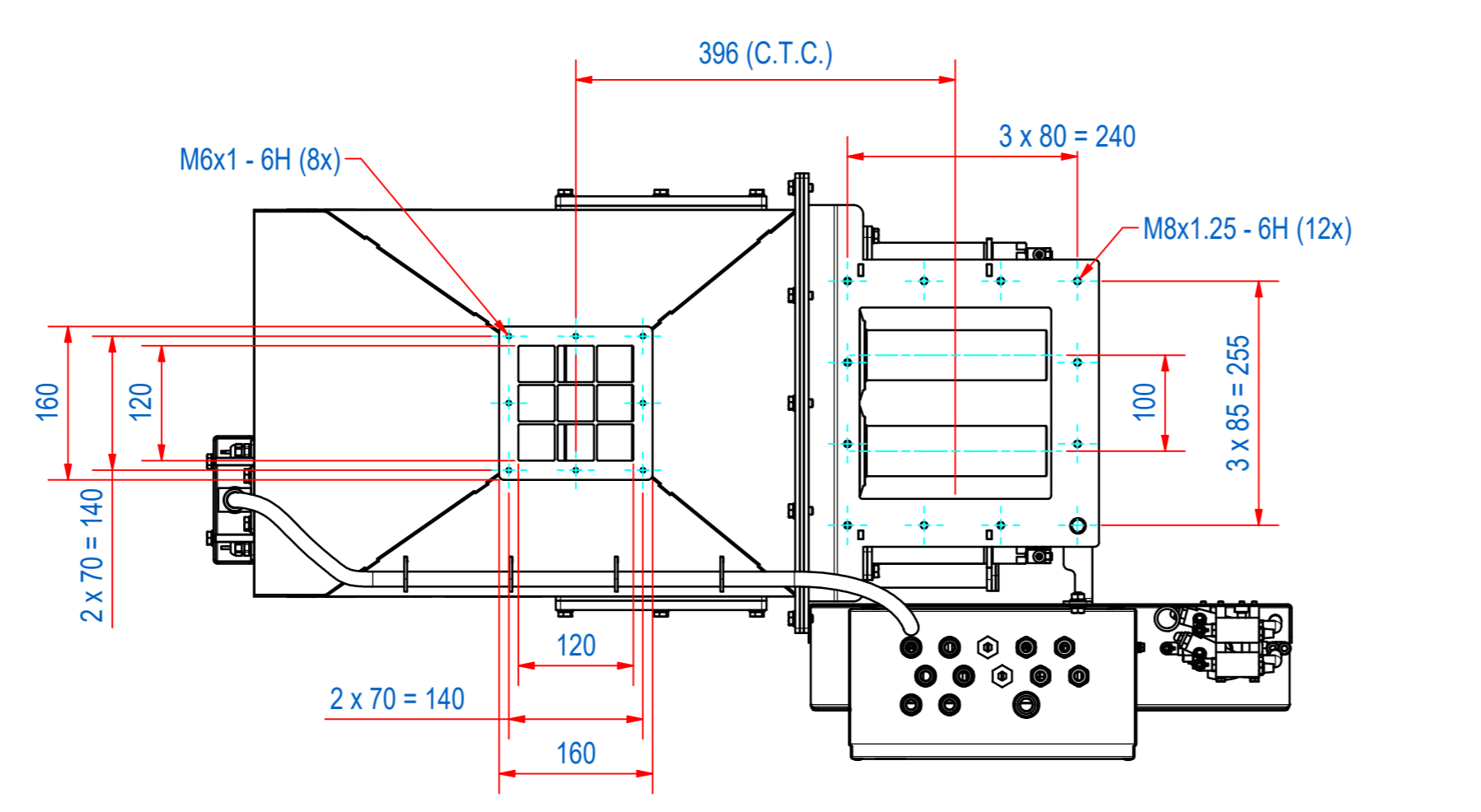
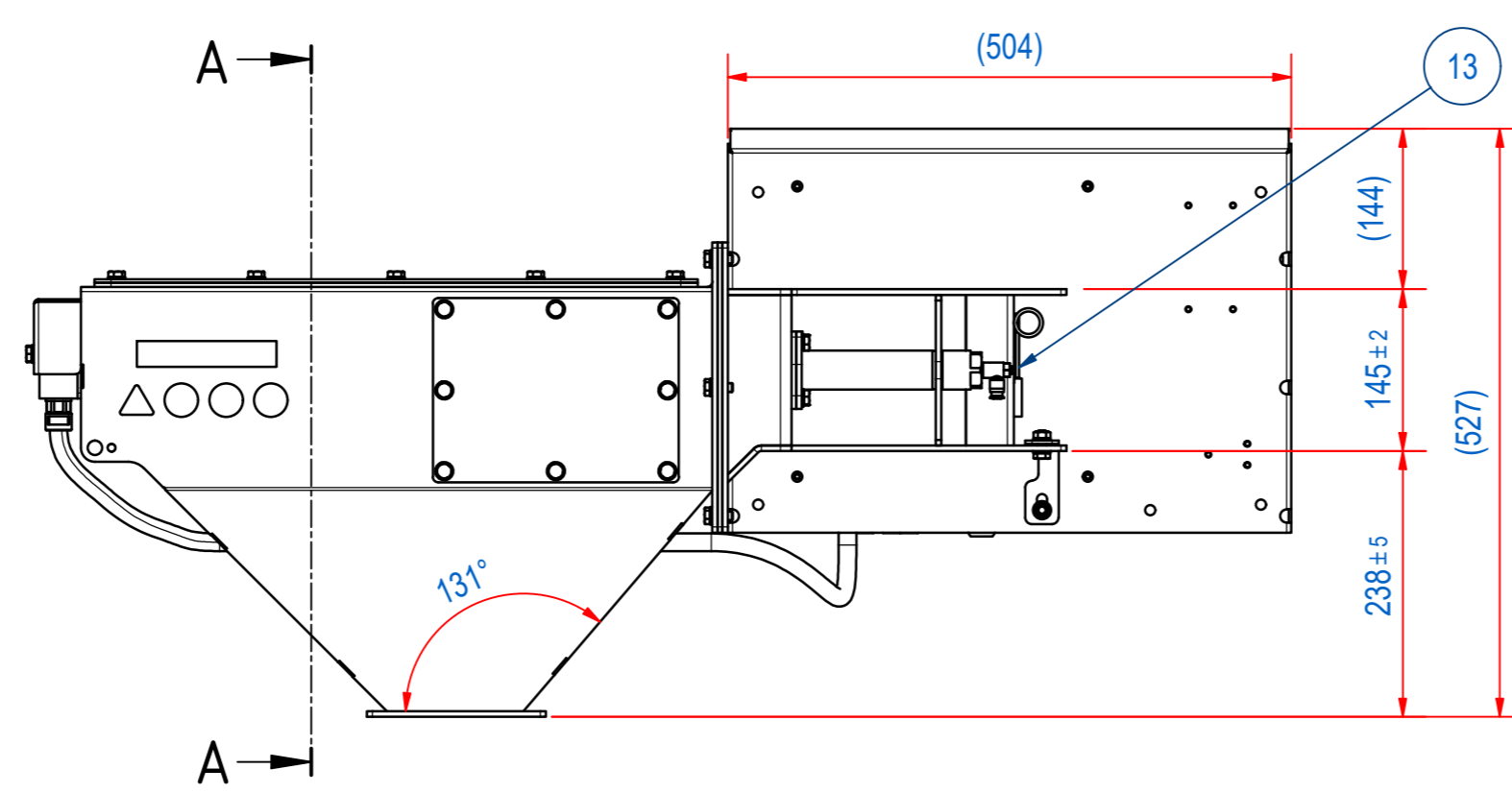
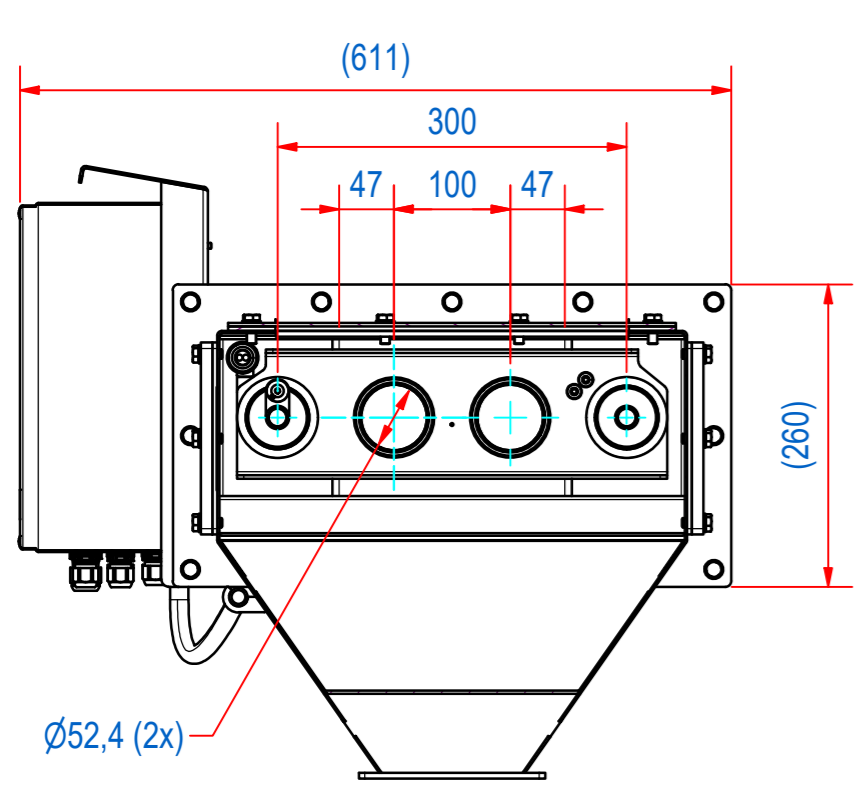
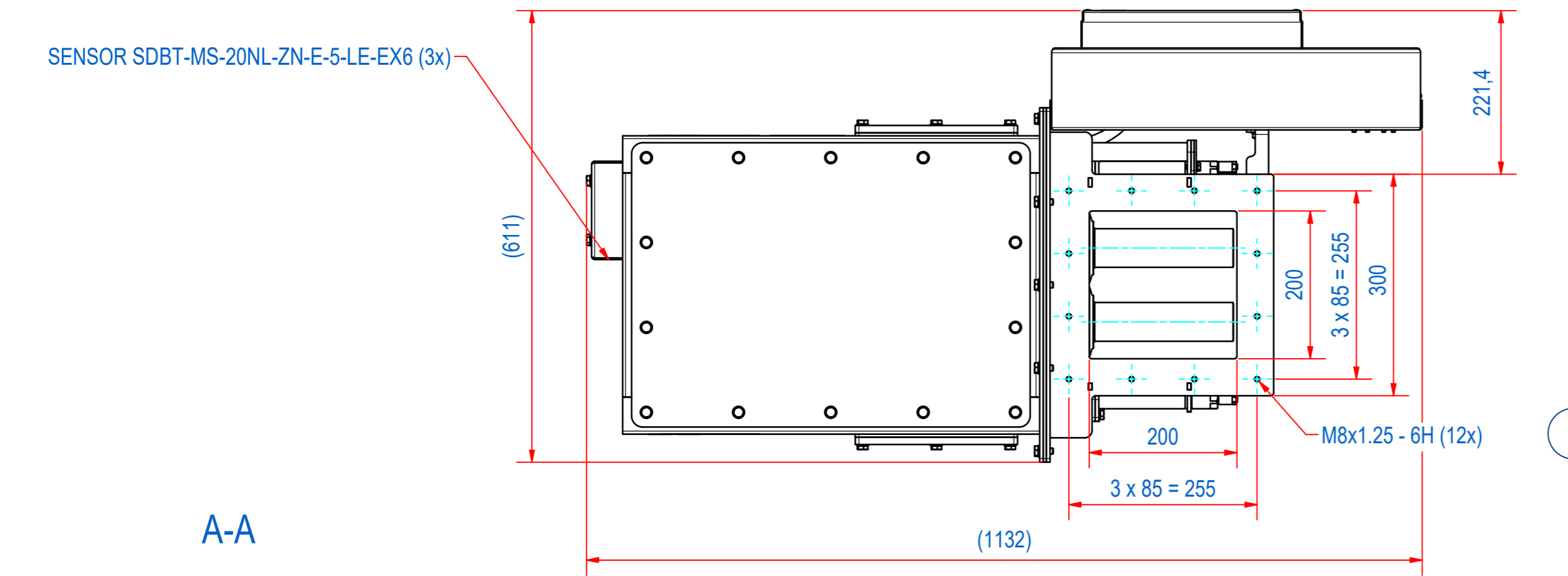

NO PRODUCT FLOW DURING CLEANING CYCLES OF MAGNETS

THIS DRAWING CORRESPONDS WITH ATEX DRAWING E0141563 (MECHANICAL ASSEMBLY)

ITEM	QTY	PART NUMBER	DESCRIPTION	Dimensions
13	3	83.9900058	SENSOR SDBT-MS-20NL-ZN-E-5-LE-EX6	
12	1	E0105723	SECA PNEUMATIC DIAGRAM	
11	1	E0106375	FLEX. HOSE PA11 AD15.8 Ex L900	
10	1	E0106204	SECA-2020-TOP COVER 316L	
9	2	E0104184	SECA-SIDE COVER GRIPHEN EC1935	
8	1	EIYR392001	CABLE GL HSK-M-MULTI-EXM20x1.5	
7	3	E0049709	SECE-S-SEAL Ø75 SIL RED EC1935	
6	1	E0103549	SECA-000-STICKERS	
5	1	E0106176	SECA-2020-HOUSE-B	
4	1	E0106178	SECA-2020-DISPOSAL HOUSING-S	
3	1	E0106206	SECA-S-2020-02V-ES MAGNET INSERT	
2	1	E0135057	SECA-TYPE PLATE ATEX Ex-X4-G1-G4-Y-Y4	
1	1	E0164668	SECA-000-PNEU-EX CONTROL UNIT	

RAW MAT.	Quantity	Material Number	Material Description	Length (mm)	Width (mm)
1	1				

Sheet: A2	Extra info: CLEANFLOW MAGNET STATIC AUTOMATIC CLEANING Ex - ATEX	General tolerance: ISO 2768 - mK
Drawn: LH	Weight (kg): 75	Drawn according: ISO286; ISO1101; ISO2553
Date: 26-3-2024	Source: MC-C	Status: Released
Spare part: False	Quick search: SECA-2020	Customer reference number:
Description: SECA-2020-02V-ES-F1m-B-P-ST-B-SR-B-S-B-C-Ex	Document number: E0164680	Doc.Rev: A
	Part number: E0164680	Rev: A



© All rights reserved. Reproduction is not permitted without written permission of GOUDSMIT Magnetic Systems BV