

3	2	1		
DOC.NR.	REV	DATE	BY	DESCRIPTION
E0168602	-	29-10-2024	LH	ORIGINAL DRAWING

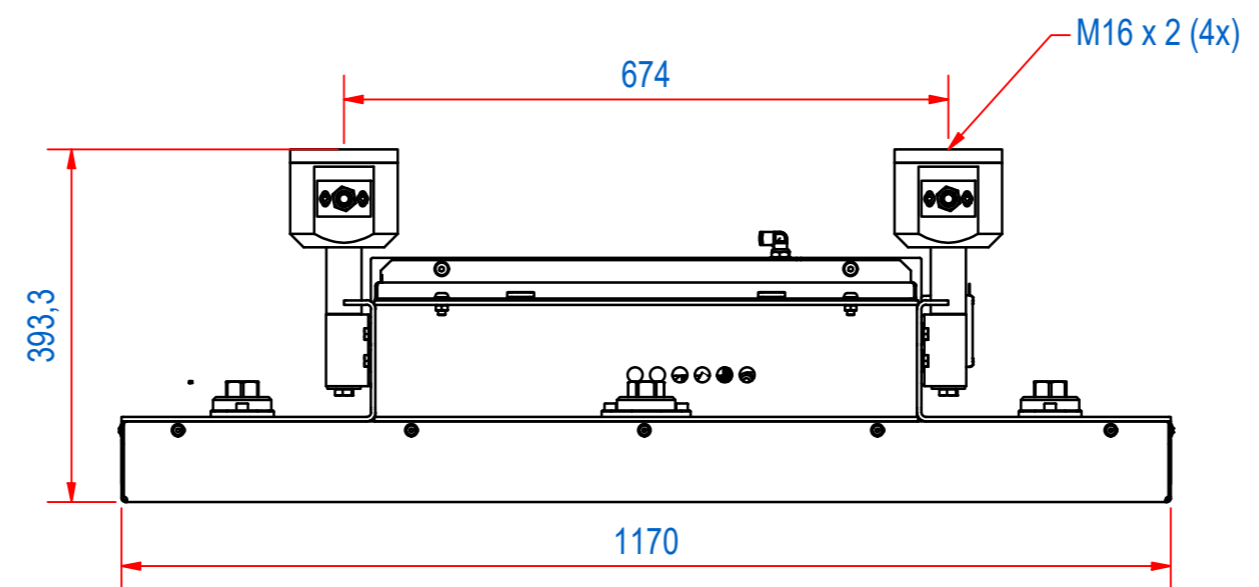
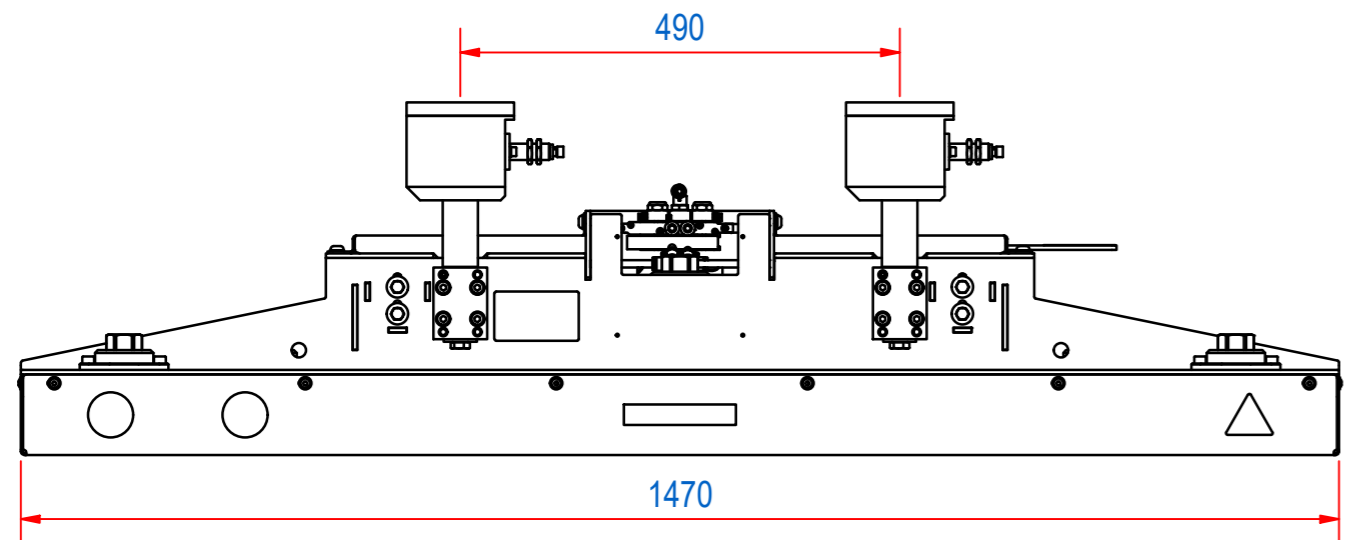
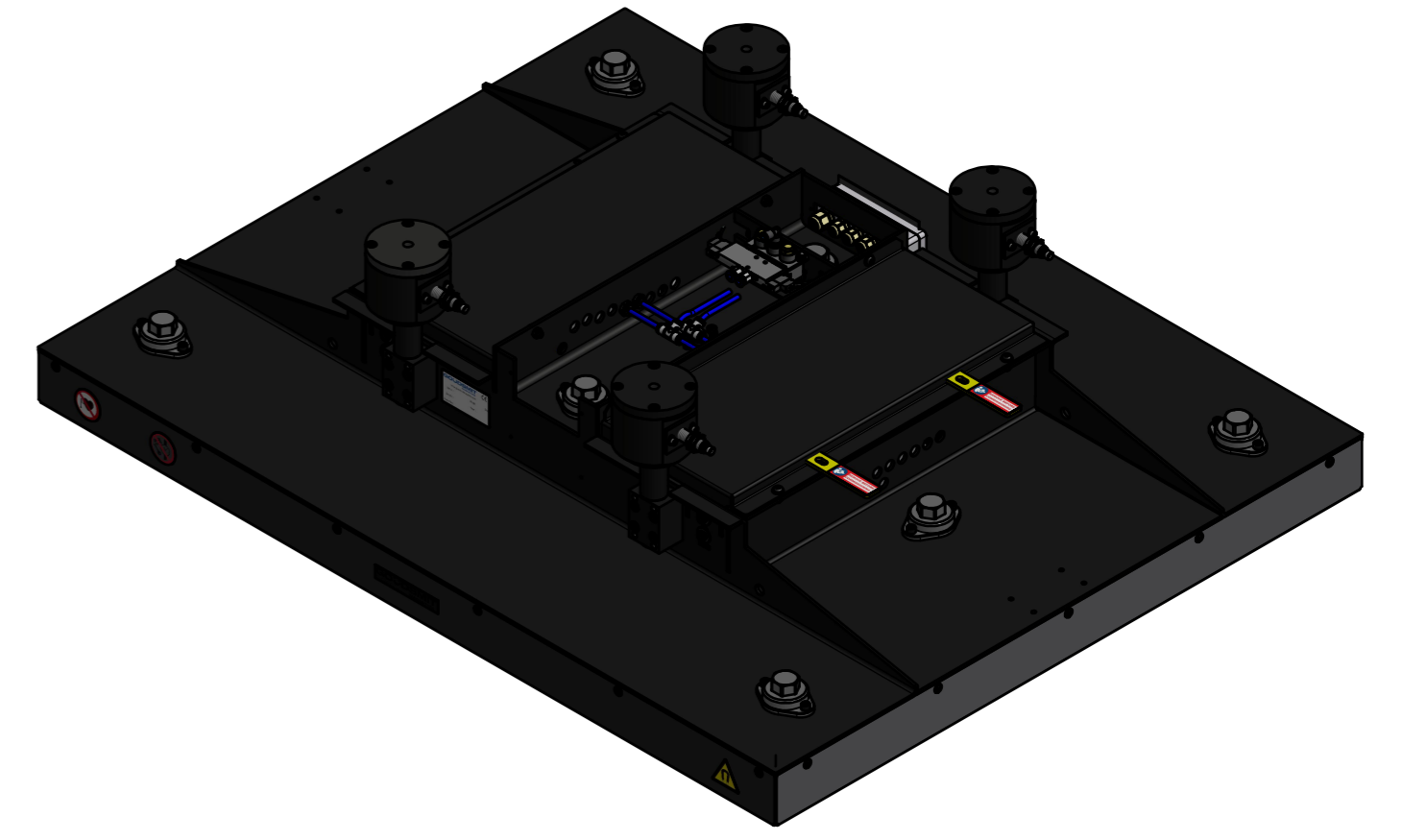
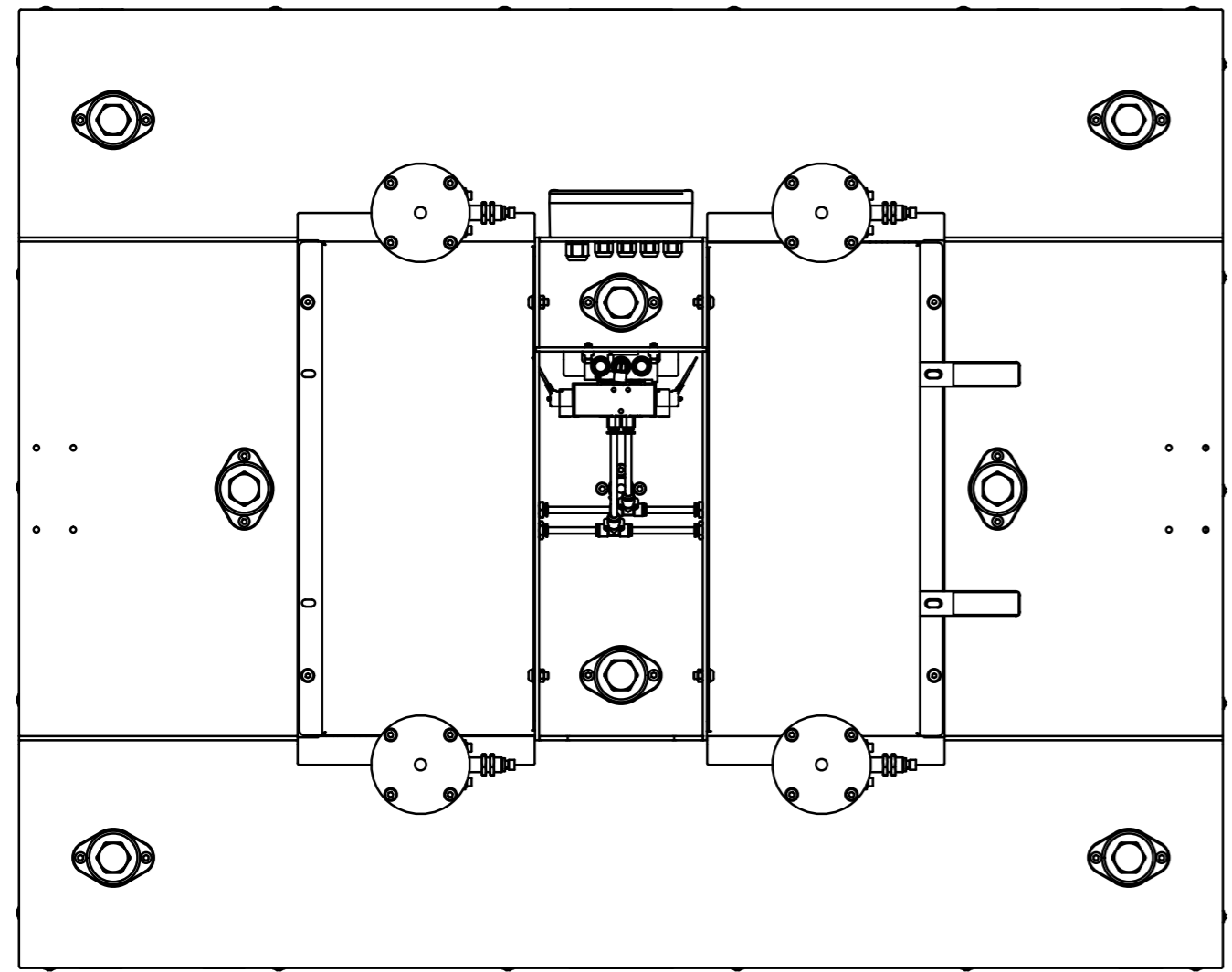

ITEM	QTY	PART NUMBER	DESCRIPTION	Dimensions
8	1	E0161413	HPA-SU-7	
7	1	E0160602	HPA-FR-1470x1170-SS	
6	8	E0159811	HPA-CO	
5	1	E0160257	HPA-E-TB-NA-N-HW	
4	1	E0164202	HPA-STICKER SET	
3	1	E0161182	HPA-PNEUMATIC MAGNET PLATE MODULE	
2	1	E0160412	HPA-CENTRAL PART	
1	1	E0160341	HPA-MP-1470x1170-M10	

RAW MAT.	Quantity	Material Number	Material Description	Length (mm)	Width (mm)
	1				

Sheet: A2	Extra info:	General tolerance: ISO 2768 - mK
Drawn: LH	Weight (kg): 320	Drawn according: ISO286; ISO1101; ISO2553
Date: 29-10-2024		Status: Released
Spare part: False	Source:	Customer reference number:
Quick search:		Document number: E0168602 Doc.Rev: -
Description: HPA-N-IM-SS-1470-1170-S7		Part number: E0168602 Rev: -



© All rights reserved. Reproduction is not permitted without written permission of GOUDSMIT Magnetic Systems BV