

3	2	1		
DOC.NR.	REV	DATE	BY	DESCRIPTION
E0168606	-	29-10-2024	LH	ORIGINAL DRAWING

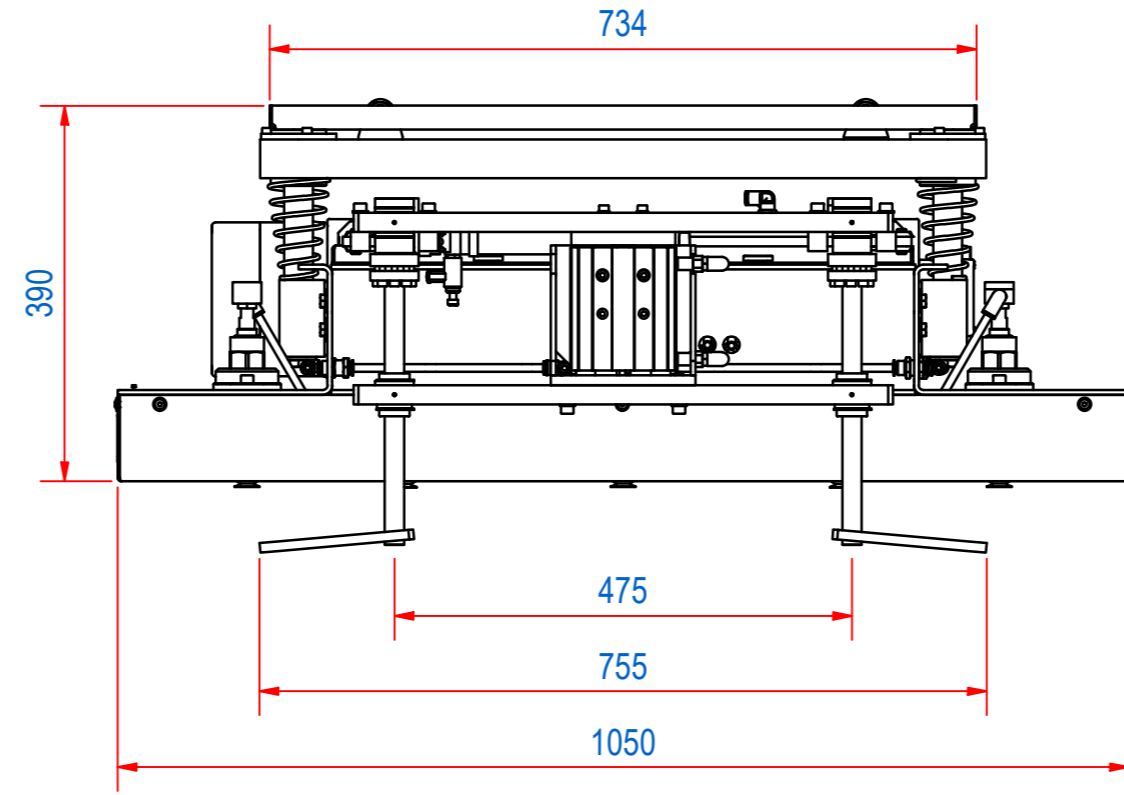
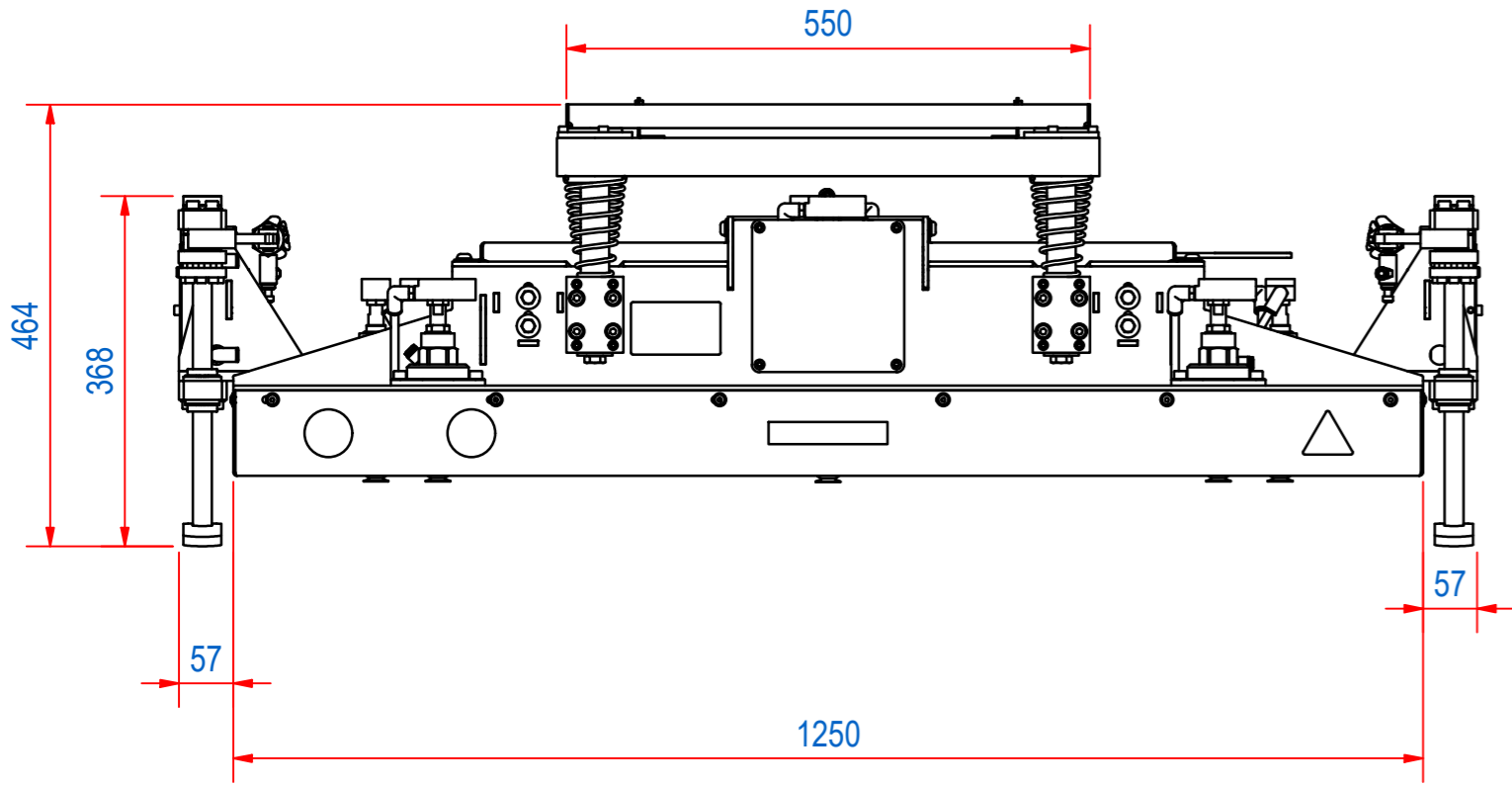
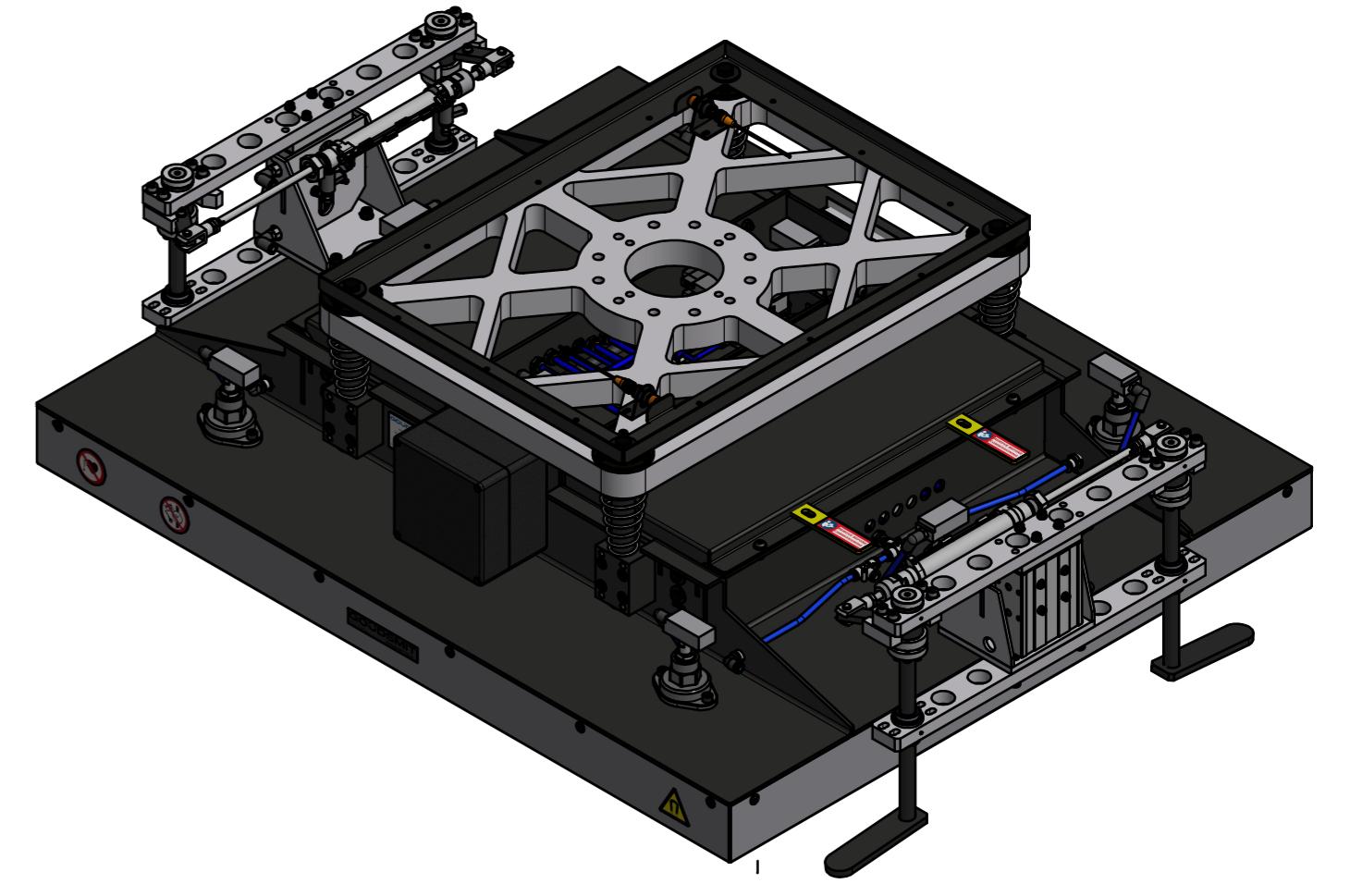
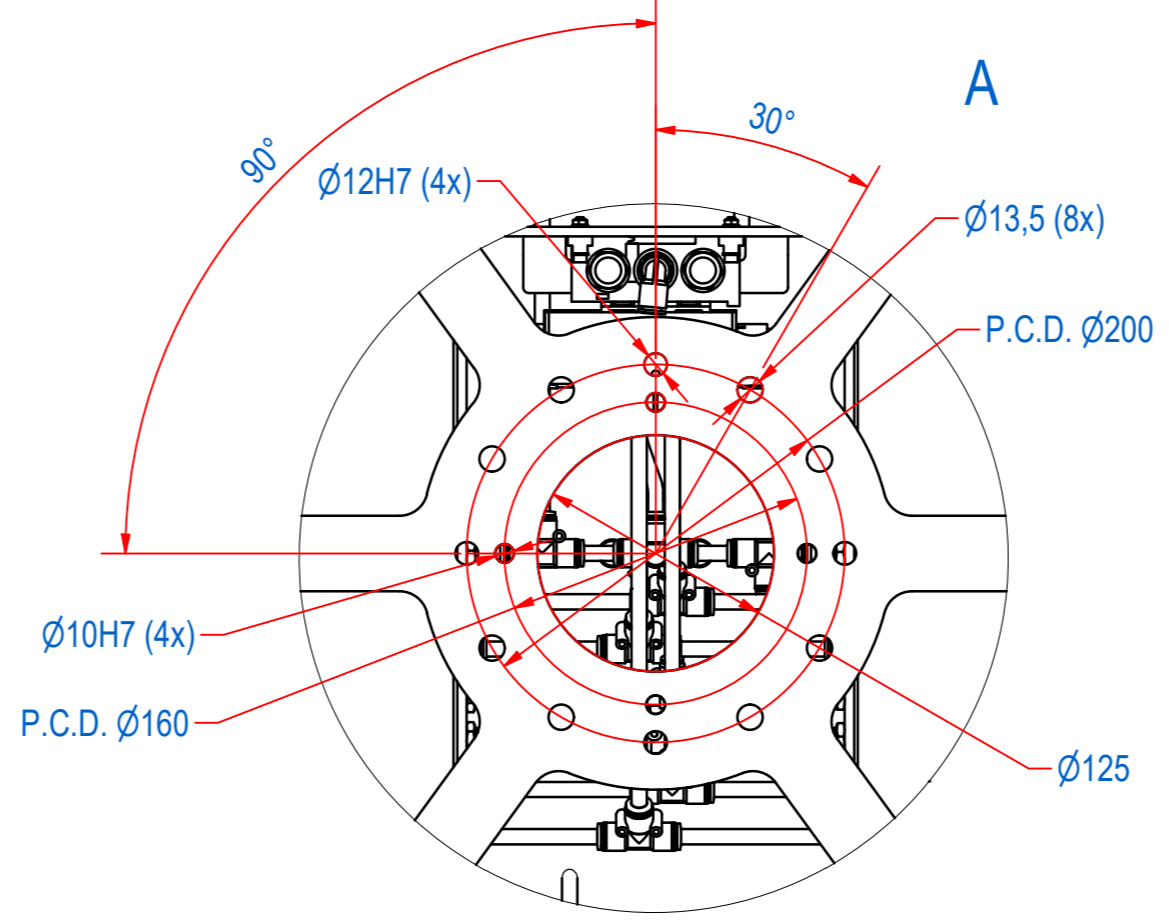
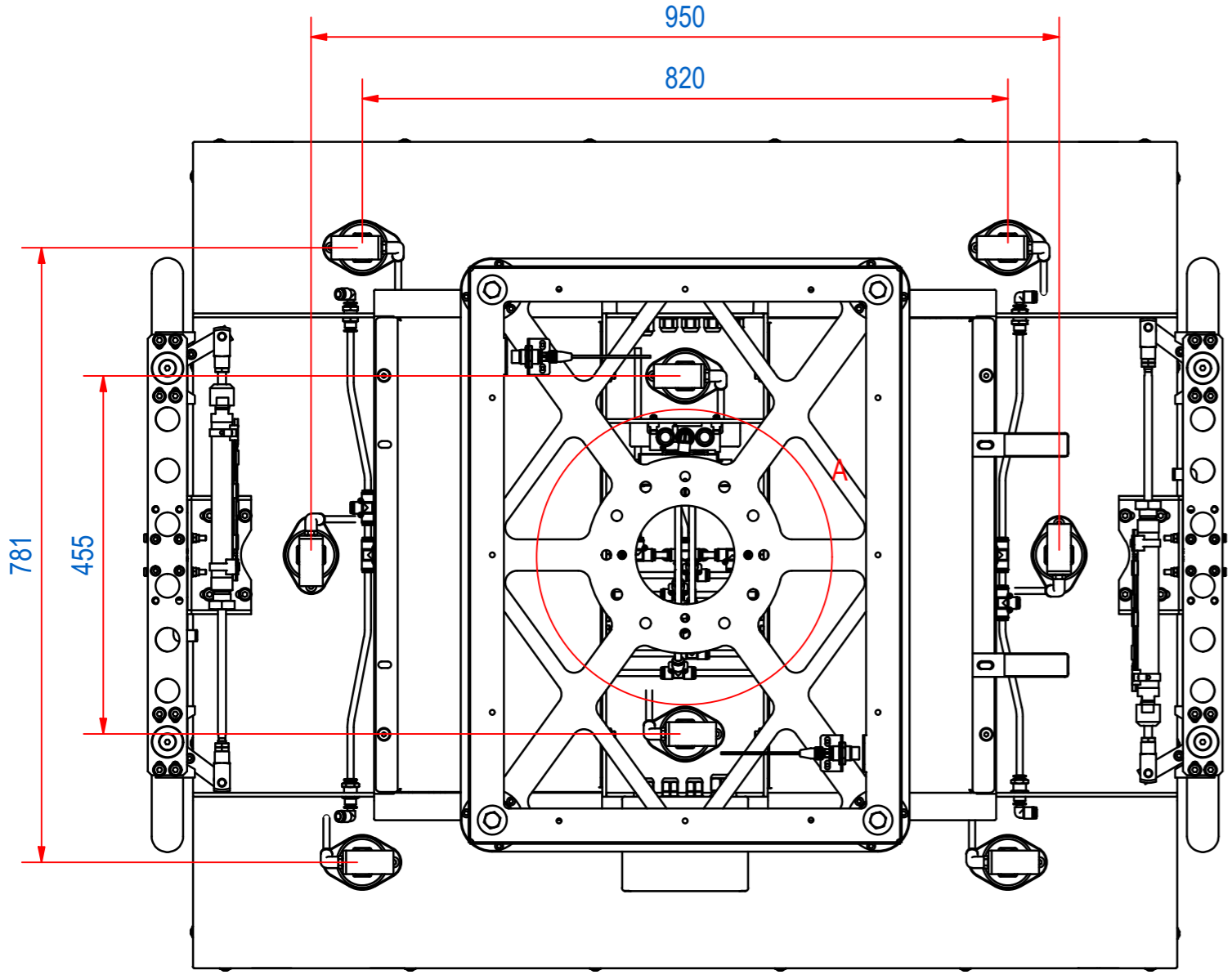

13	2	E0161076	HPA-VG-H	
12	6	E0161075	HPA-VG-L	
11	1	E0160603	HPA-FR-1250x1050-SS	
10	1	E0161183	HPA-PNEUMATIC VACUUM MODULE	
9	1	E0160174	HPA-E-TB-NA-N-HW	
8	1	E0161184	HPA- PNEUMATIC PALLET GRAB UNIT MODULE	
7	2	E0160163	HPA-PG	
6	1	E0161267	HPA-SU-3	
5	1	E0160257	HPA-E-TB-NA-N-HW	
4	1	E0164202	HPA-STICKER SET	
3	1	E0161182	HPA-PNEUMATIC MAGNET PLATE MODULE	
2	1	E0160412	HPA-CENTRAL PART	
1	1	E0159641	HPA-MP-1250x1050-F	
ITEM	QTY	PART NUMBER	DESCRIPTION	Dimensions

RAW MAT.	Quantity	Material Number	Material Description	Length (mm)	Width (mm)
⊕	Sheet:	A2	Extra info:	General tolerance: ISO 2768 - mK	
Drawn:	Weight (kg):	LH	315	Drawn according: ISO286; ISO1101; ISO2553	
Date:	29-10-2024			Status: Released	
Spare part:	Source:	False			Customer reference number:
Quick search:	GOUDSMIT MAGNETICS			Document number:	Doc.Rev:
Description:	HPA-N-IF-SS-1250-1050-VS3P			Part number:	Rev:
				E0168606	-