

DOC.NR.	REV	DATE	BY	DESCRIPTION
EHSQ090000	A	21-6-2023	GS	connector + cable + PCB changed+flange added
EHSQ090000	B	19-8-2024	GS	REVISED STICKER AND CORE BUSH; NEW COIL
EHSQ090000	C	13-11-2024	GS	added safety sticker; changed E0143799

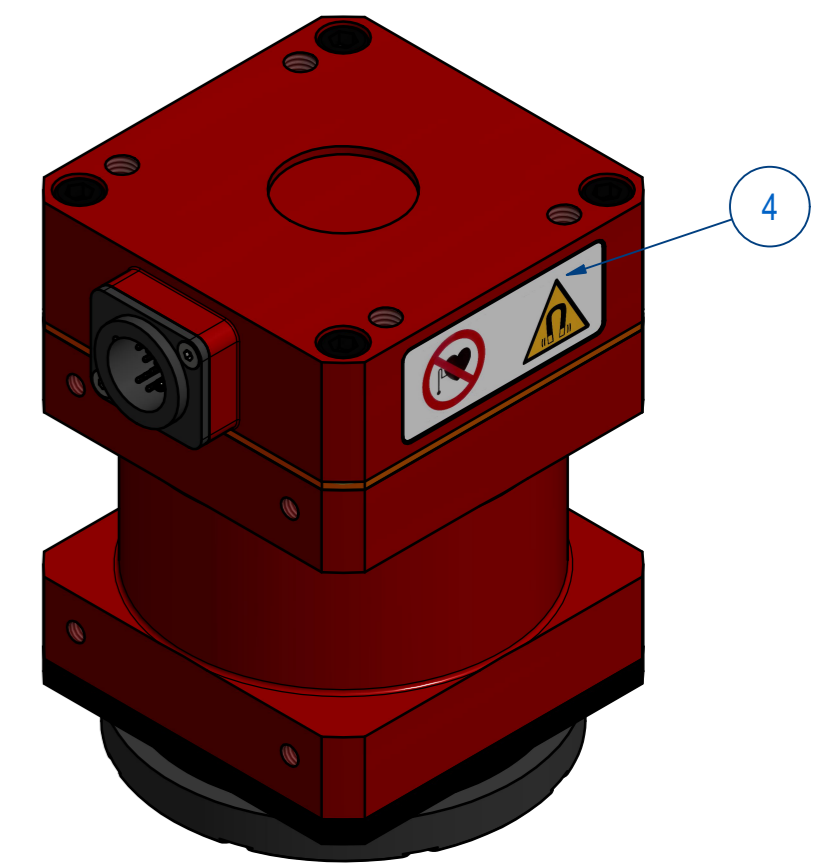
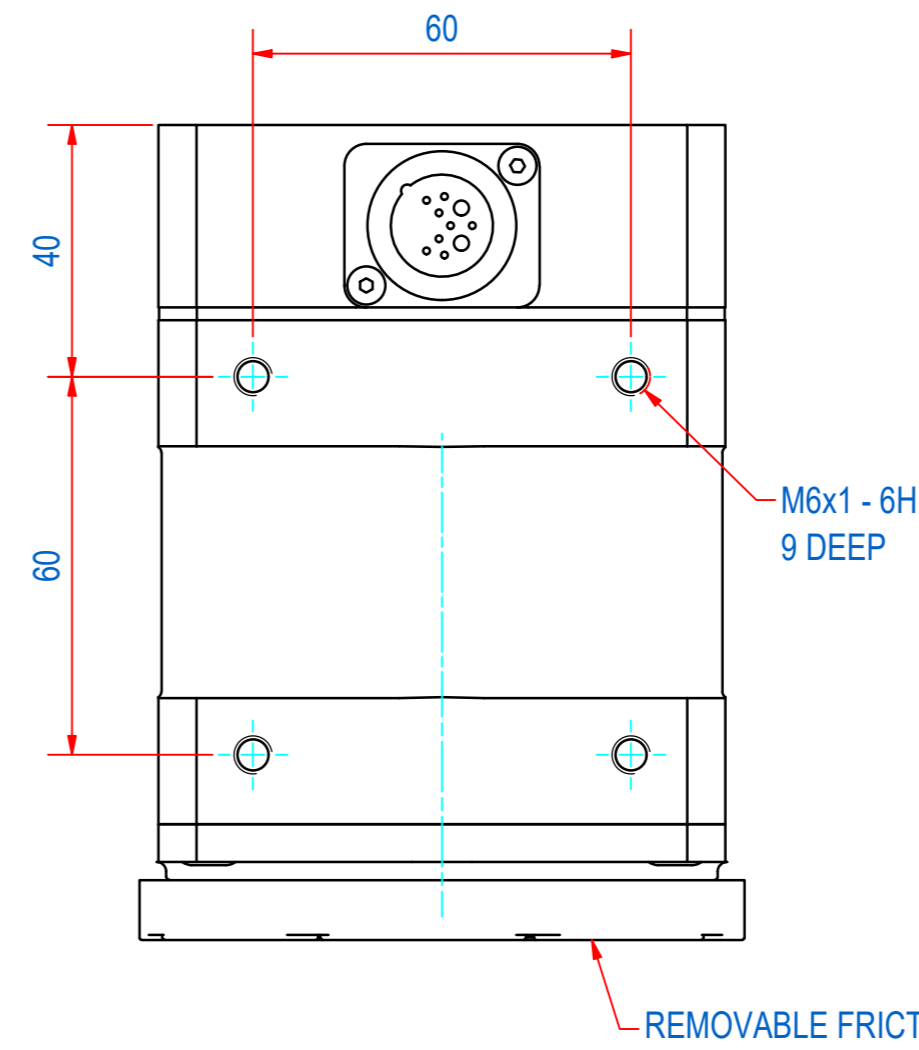
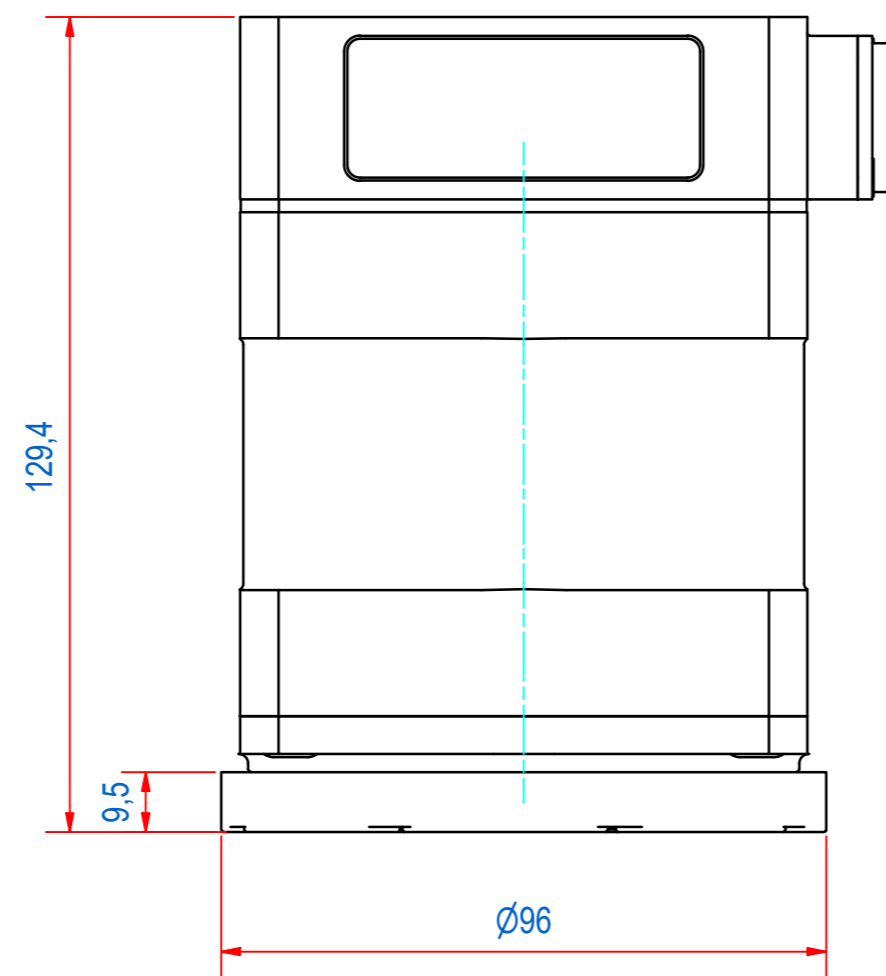
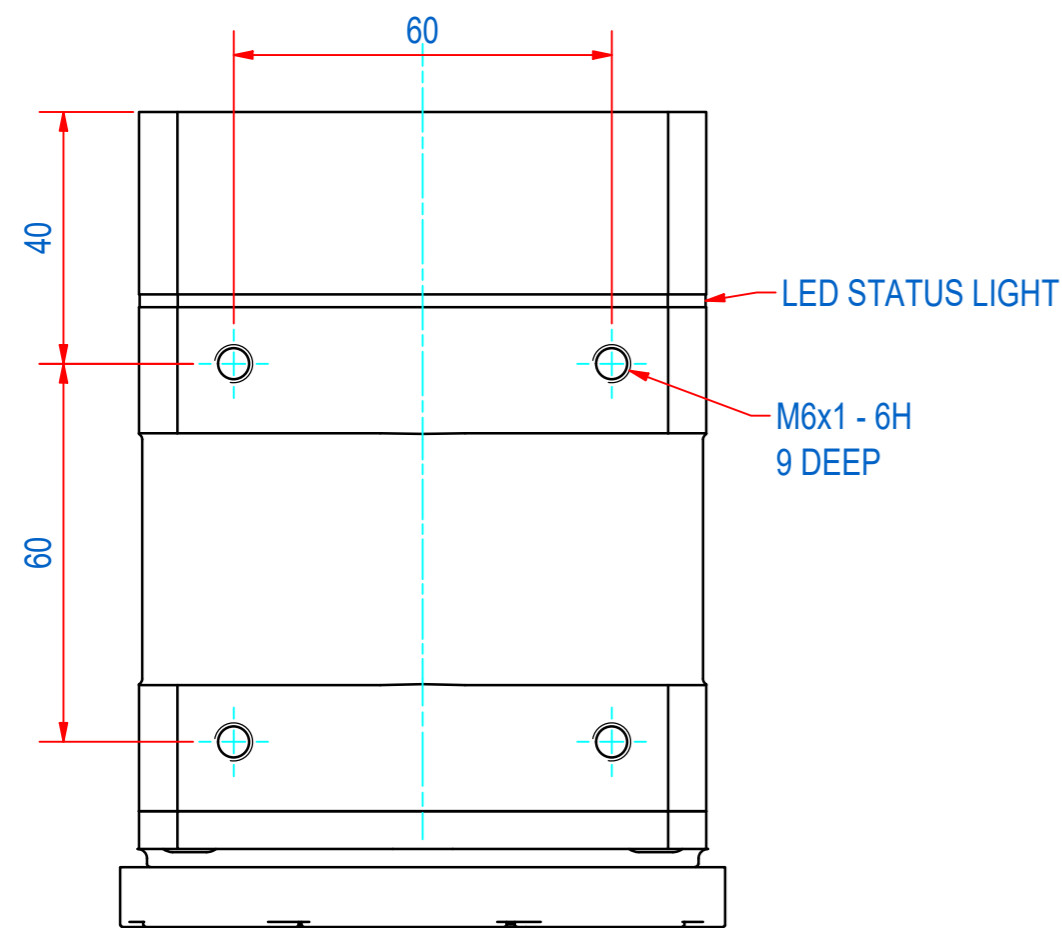
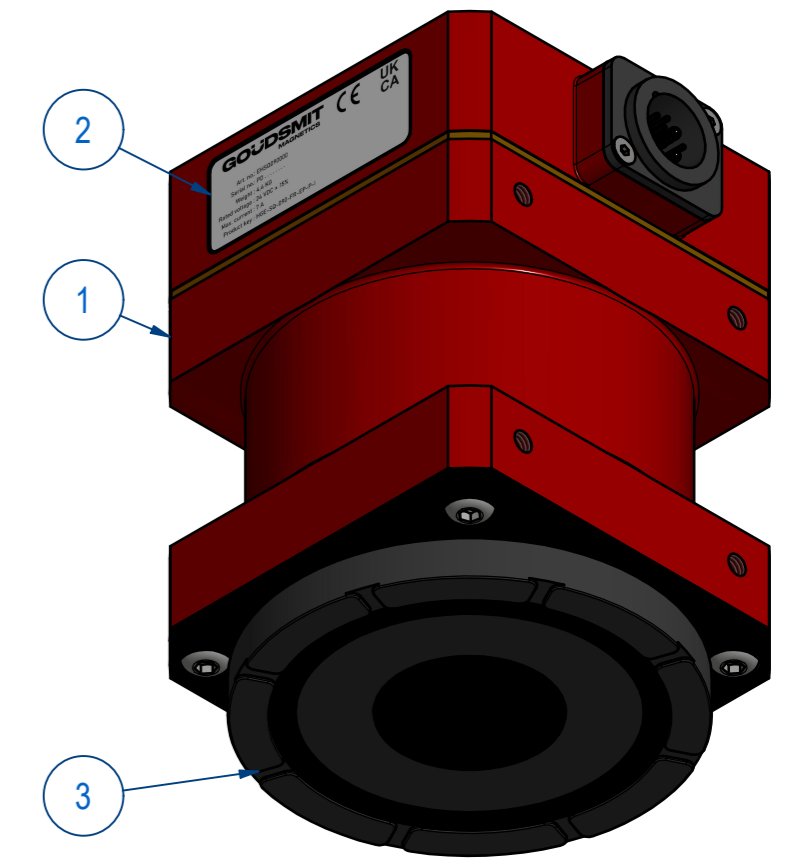
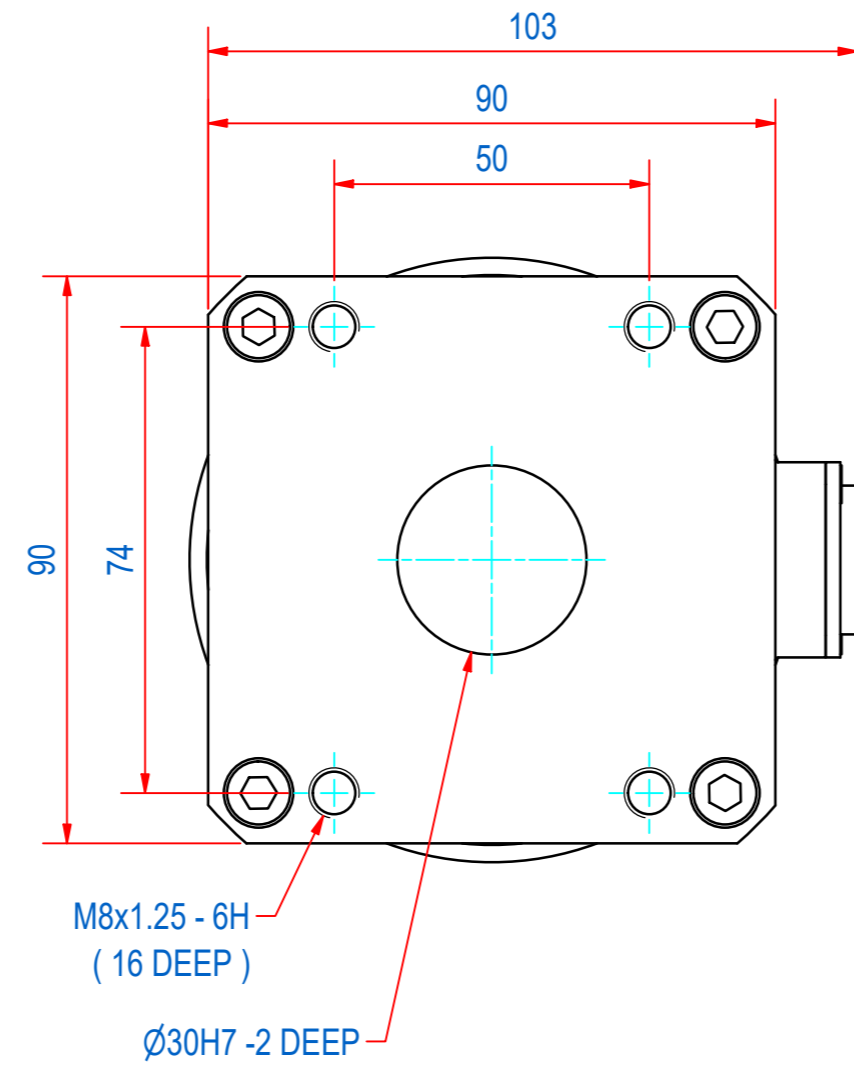

4	1	E0168975	HGE-SAFETY STICKER 56x22	
3	1	E0154864	HEPM-FRICTION RING 90	
2	1	E0158467	HGE-090 STICKER	
1	1	E0143798	HGE-090 MAIN ASSY	
ITEM	QTY	PART NUMBER	DESCRIPTION	Dimensions
RAW MAT.	1			
	Quantity	Material Number	Material Description	Length (mm) Width (mm)
⌀	Sheet: A2	Extra info: RATED VOLTAGE = 24 V DC MAX. CURRENT POWER = 7 A	General tolerance: ISO 2768 - mK	
Drawn: GS	Weight (kg): 4,4		Drawn according: ISO286; ISO1101; ISO2553	
Date: 22-6-2021			Status: Released	
Spare part: False	Source:	GOUDSMIT MAGNETICS	Customer reference number:	
Quick search: HGE090		© All rights reserved. Reproduction is not permitted without written permission of GOUDSMIT Magnetic Systems BV	Document number: EHSQ090000	Doc.Rev: C
Description: HGE-SQ-090-FR-EP-P-I			Part number: EHSQ090000	Rev: C