

3	2	1		
DOC.NR.	REV	DATE	BY	DESCRIPTION
	-	26-6-2014	PB	NEW VAULT, NEW REVISION. E0018256 WAS M36364
TRBD400114	A	17-7-2024	PB	ADDED d107x9.5 (2x) (NEXUS MB)

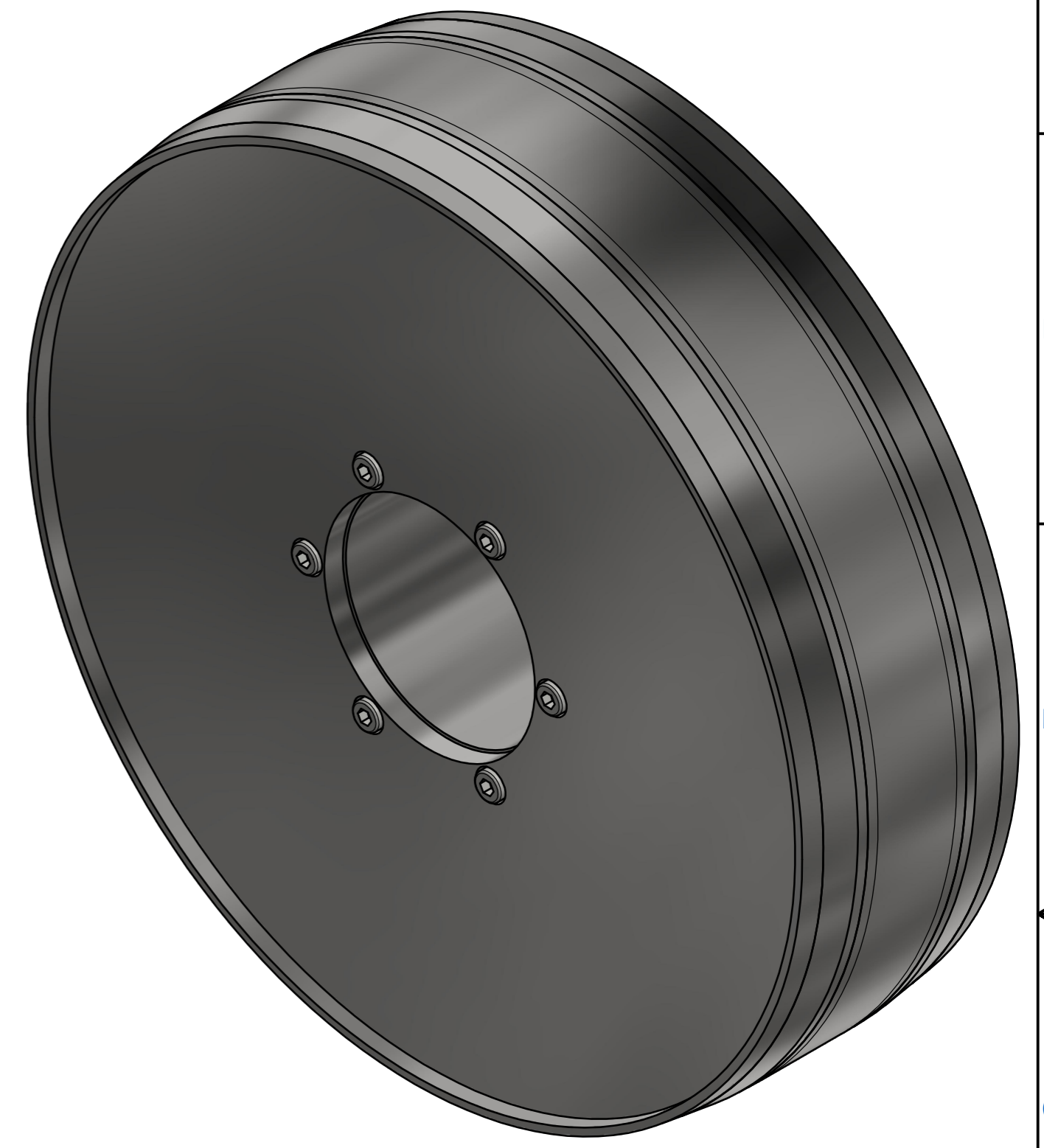
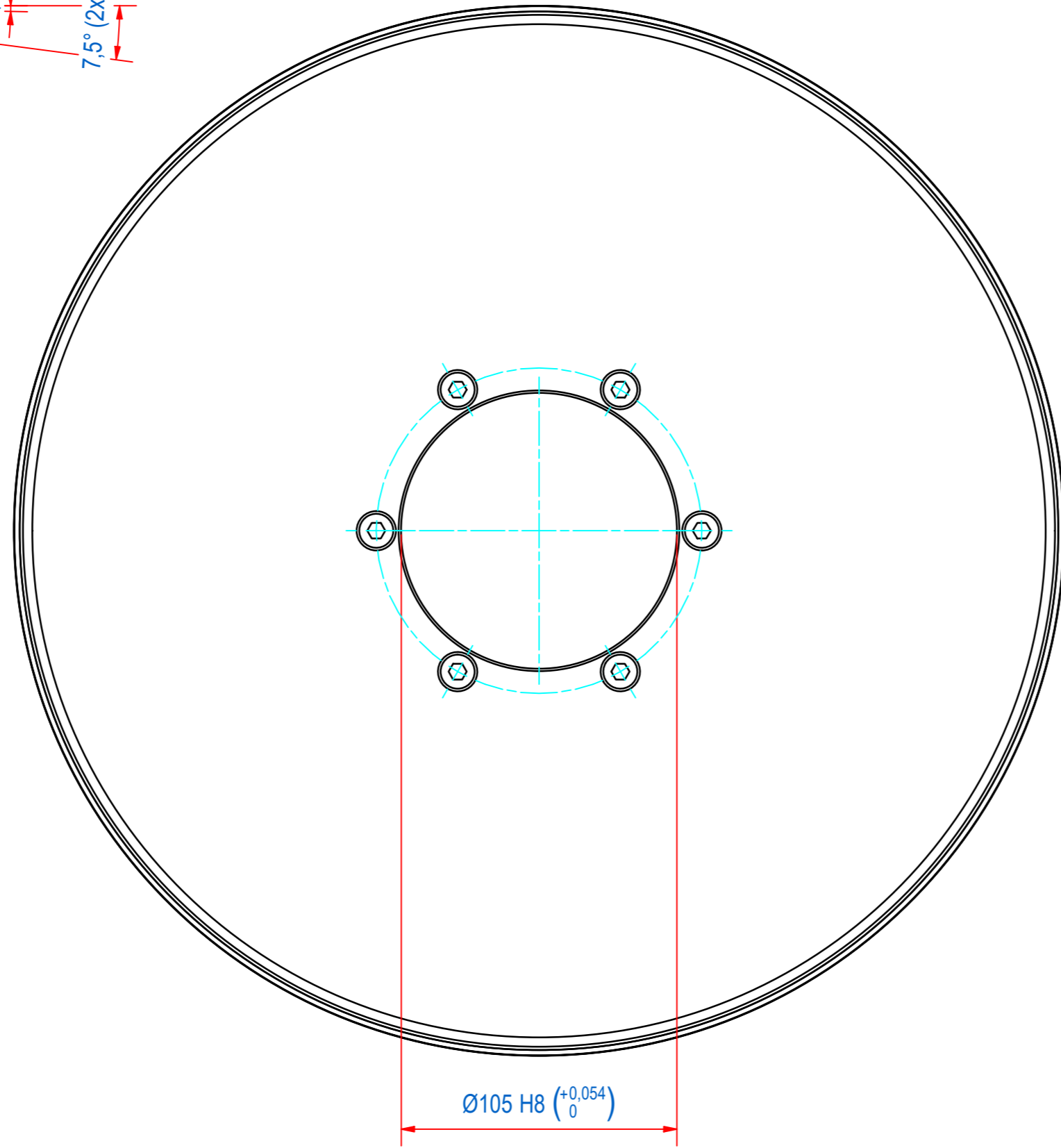
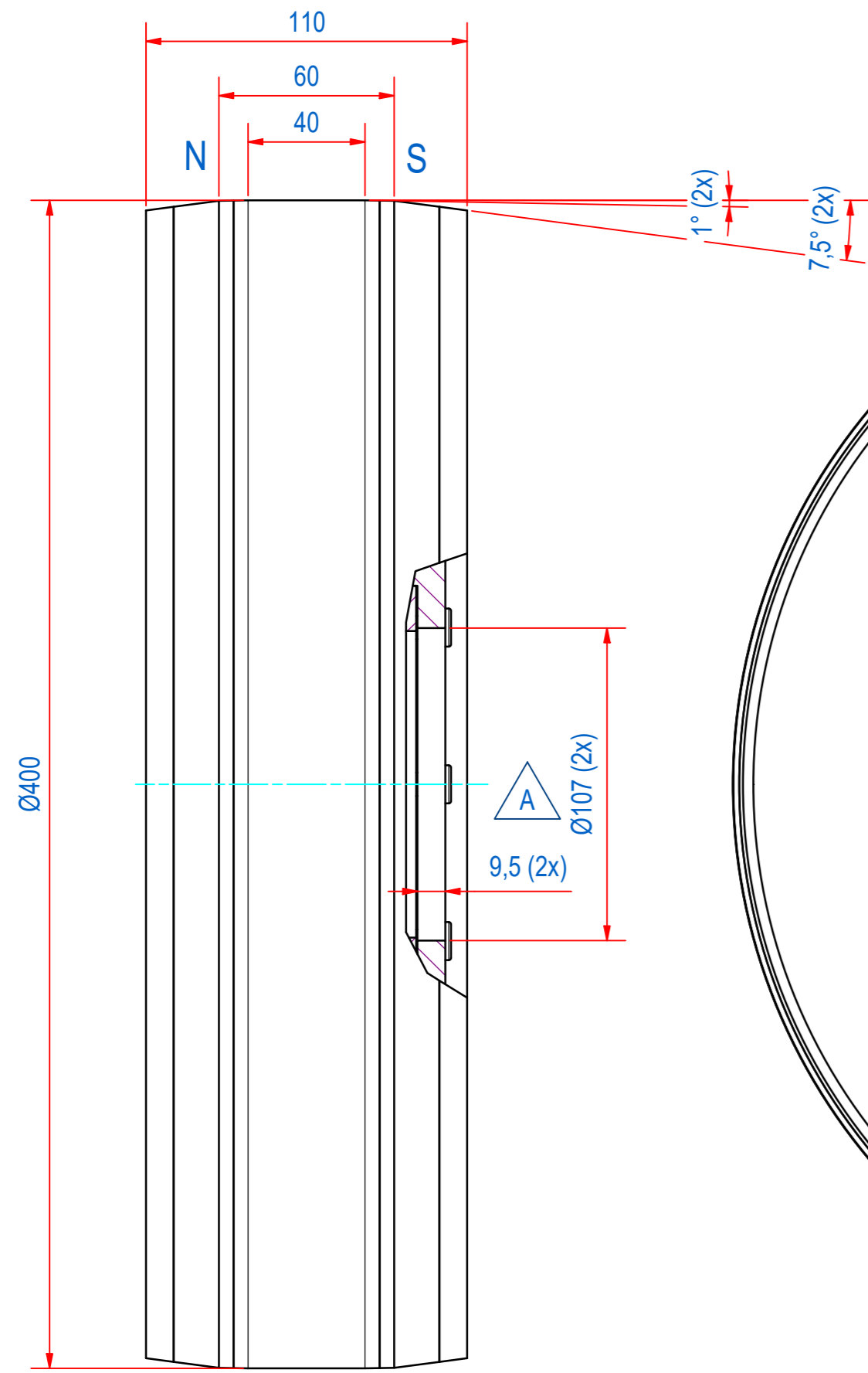

CHEMICAL NICKEL PLATING 20-25 µm BEFORE MAGNETIZING ROLLER
TOLERANCES EN FITS TO BE APPLIED AFTER PLATING

VOOR MAGNETISEREN CHEMISCH VERNIKKELEN 20-25 µm
TOLERANTIES EN PASSINGEN GELDEN NA VERNIKKELEN

1	1	E0018256	ASSEMBLY DRAWING	
ITEM	QTY	PART NUMBER	DESCRIPTION	Dimensions
RAW MAT.	1			
Quantity	Material Number	Material Description	Length (mm)	Width (mm)
Sheet:	A2	Extra info: MAGNETIC ROLLER SPLASH & SPRAY WATER PROOF NICKEL PLATED (ST/AISI)	General tolerance: ISO 2768- mK	
Drawn:	PB	Weight (kg): 54	Drawn according: ISO286; ISO1101; ISO2553	
Date:	26-6-2014		Status: Standard	
Spare part:	False		Customer reference number:	
Quick search:	TRBD110		Document number: TRBD400114	Doc.Rev: A
Description:	HRC-F-D400-d105-110-MR-N		Part number: TRBD400114	Rev: A