

| DOC.NR.    | REV | DATE       | BY | DESCRIPTION    |
|------------|-----|------------|----|----------------|
| TRUS010002 | -   | 21-12-2018 | GS | COPY FROM ACAD |
| TRUS010002 | A   | 18-12-2024 | PB | STICKERS ADDED |

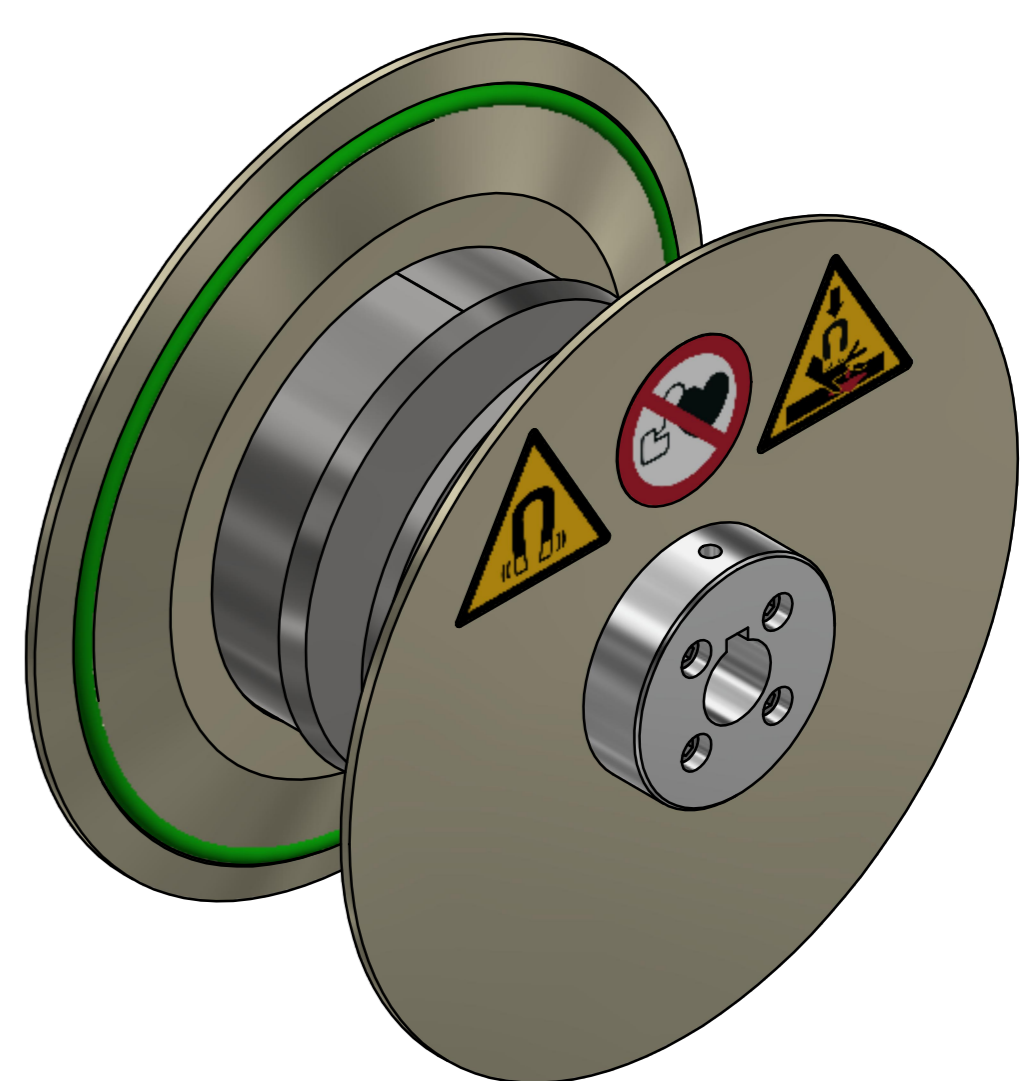
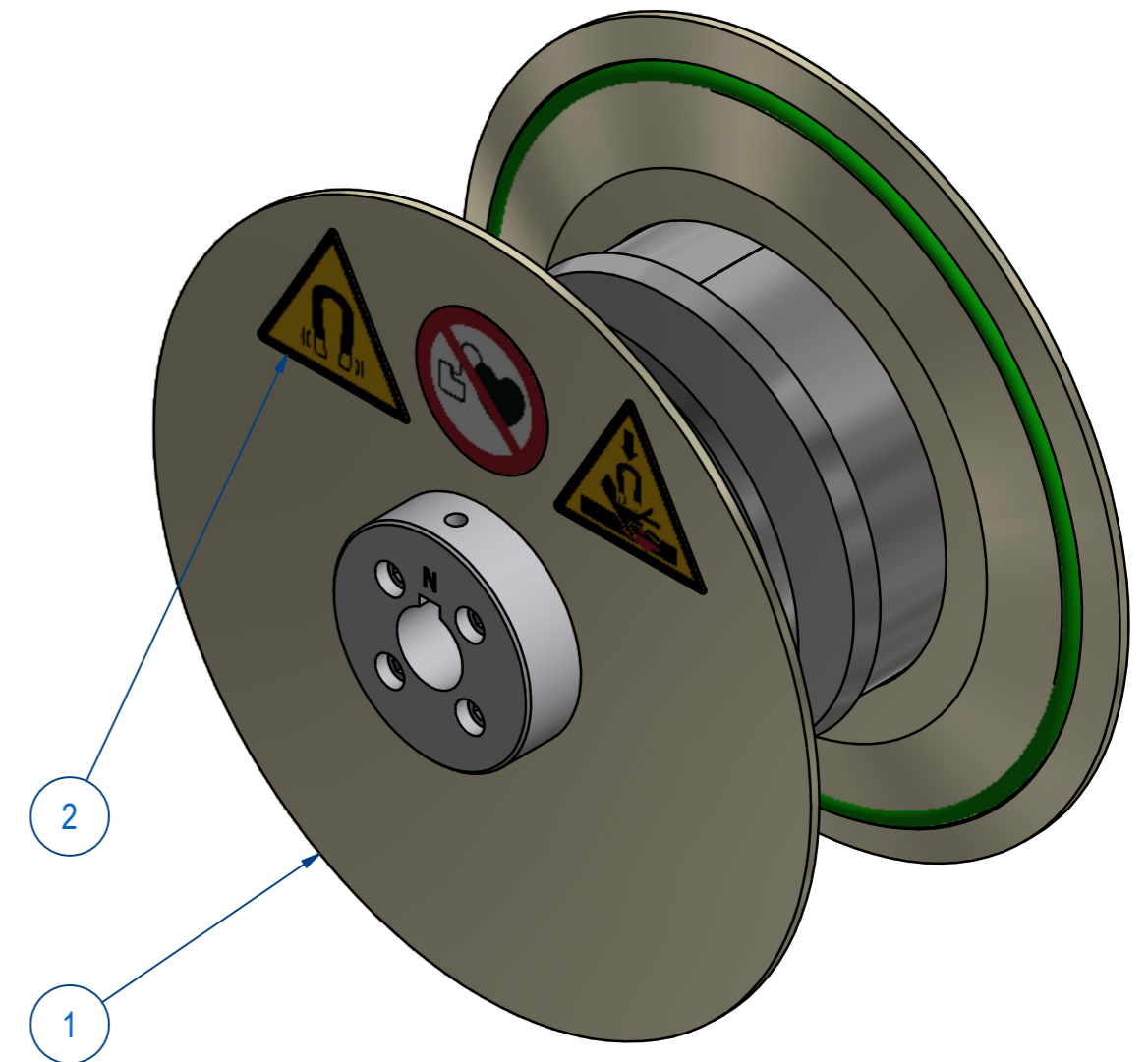
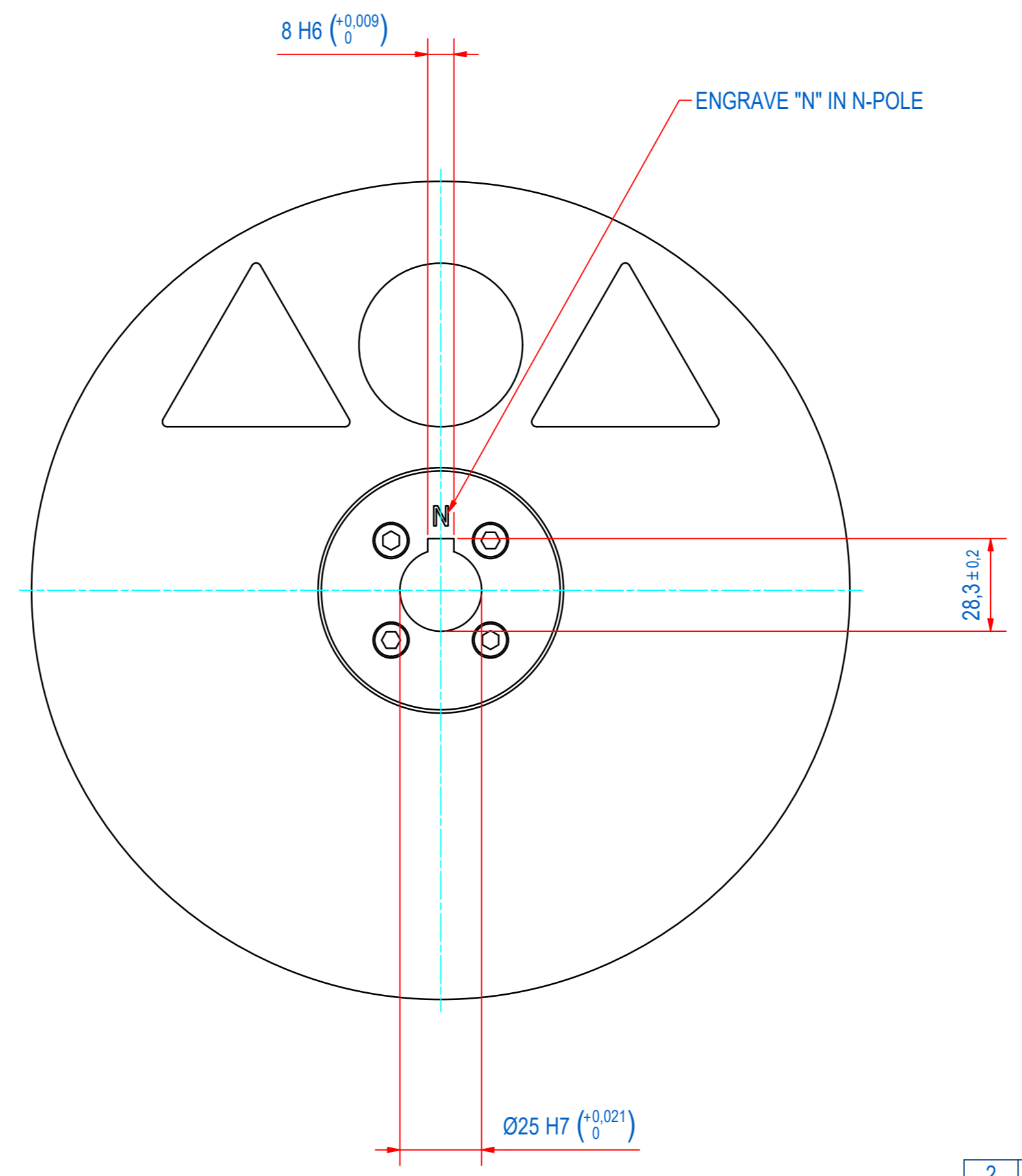
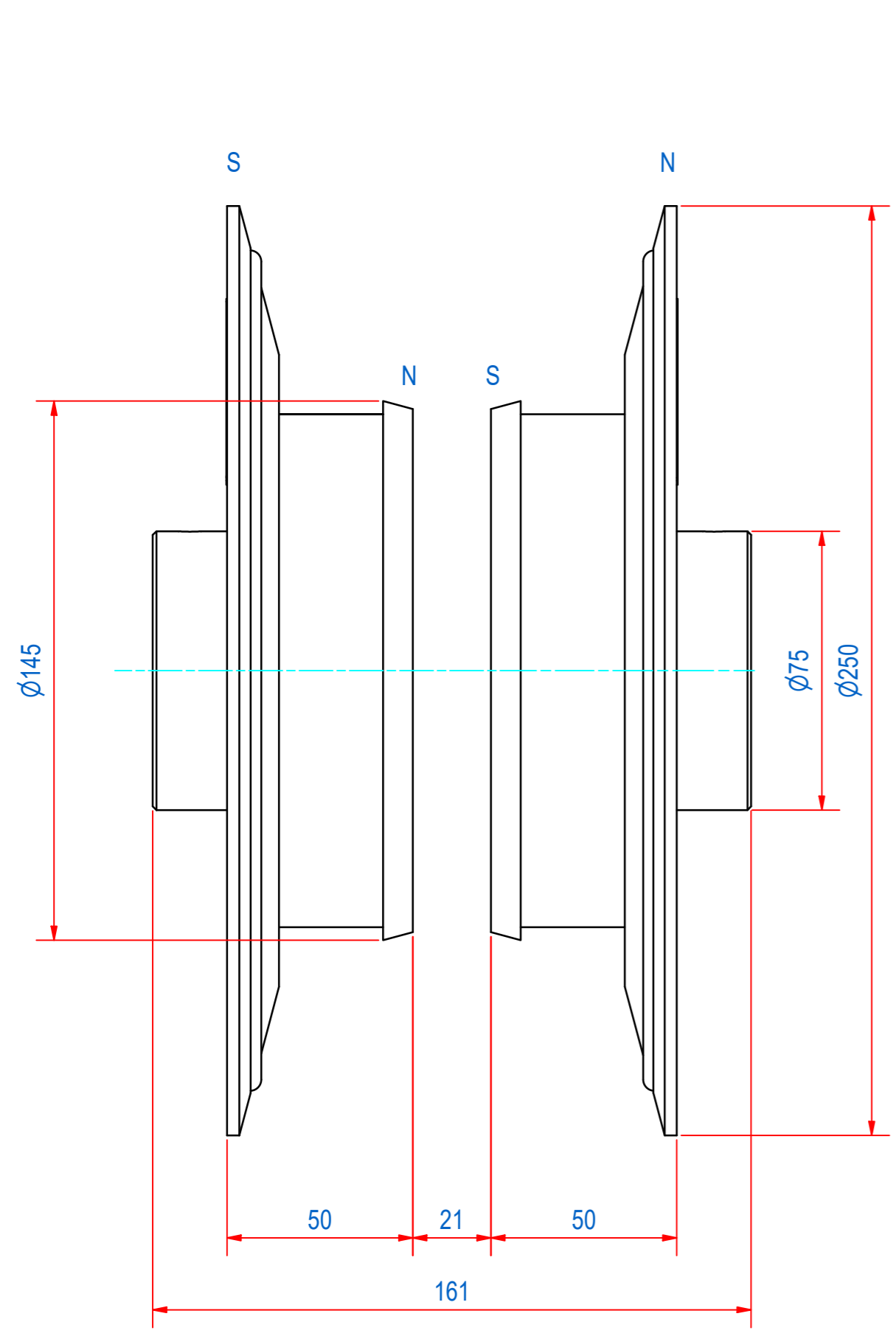

| ITEM          | QTY                    | PART NUMBER     | DESCRIPTION                    | Dimensions                                |
|---------------|------------------------|-----------------|--------------------------------|-------------------------------------------|
| 2             | 2                      | 1000.20173      | GEN-STICKER 3 WARNINGS 50mm ST |                                           |
| 1             | 1                      | E0107584        | HRL-TURNING + MILLING ASSEMBLY |                                           |
| RAW MAT.      | 1                      |                 |                                |                                           |
| Quantity      |                        | Material Number | Material Description           | Length (mm) Width (mm)                    |
| Sheet:        | A2                     | Extra info:     | MAGNETIC ROLLER LID STACK      | General tolerance: ISO 2768- mK           |
| Drawn:        | GS                     | Weight (kg):    | 14                             | Drawn according: ISO286; ISO1101; ISO2553 |
| Date:         | 21-12-2018             | Status:         | Standard                       |                                           |
| Spare part:   | False                  | Source:         |                                | Customer reference number:                |
| Quick search: | TRUS                   |                 |                                | Document number: TRUS010002 Doc.Rev: A    |
| Description:  | HRL-F-090/130-d025-B-F |                 |                                | Part number: TRUS010002 Rev: A            |