

REV	DATE	BY	DESCRIPTION
-	4-9-2014	AvD	REFERENCE DRAWING E0014903
A	23-2-2016	CR	EHDG LOGO AND NAME PLATE ADDED O-RING CHANGED: EPDM WAS SILICONE

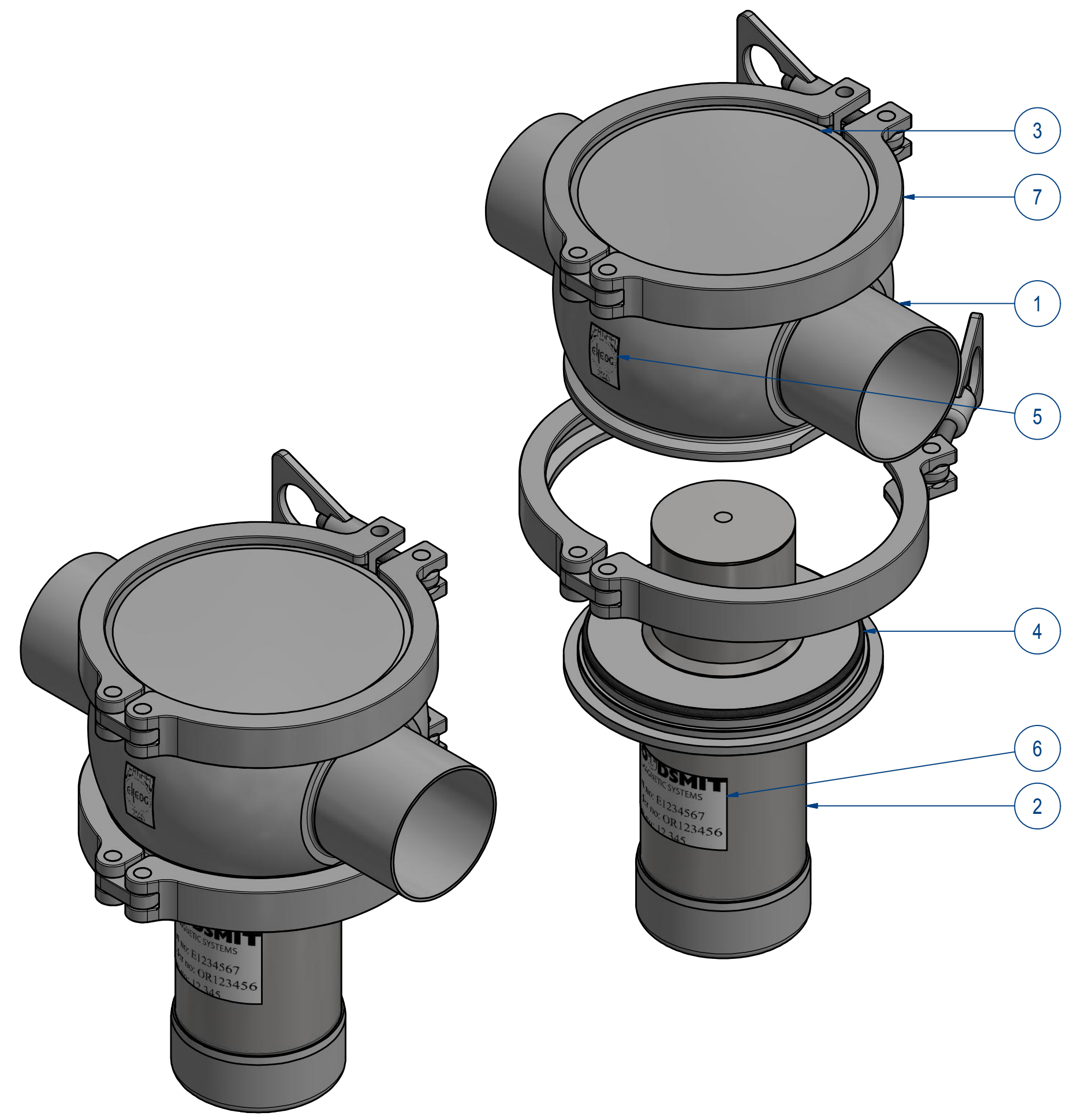
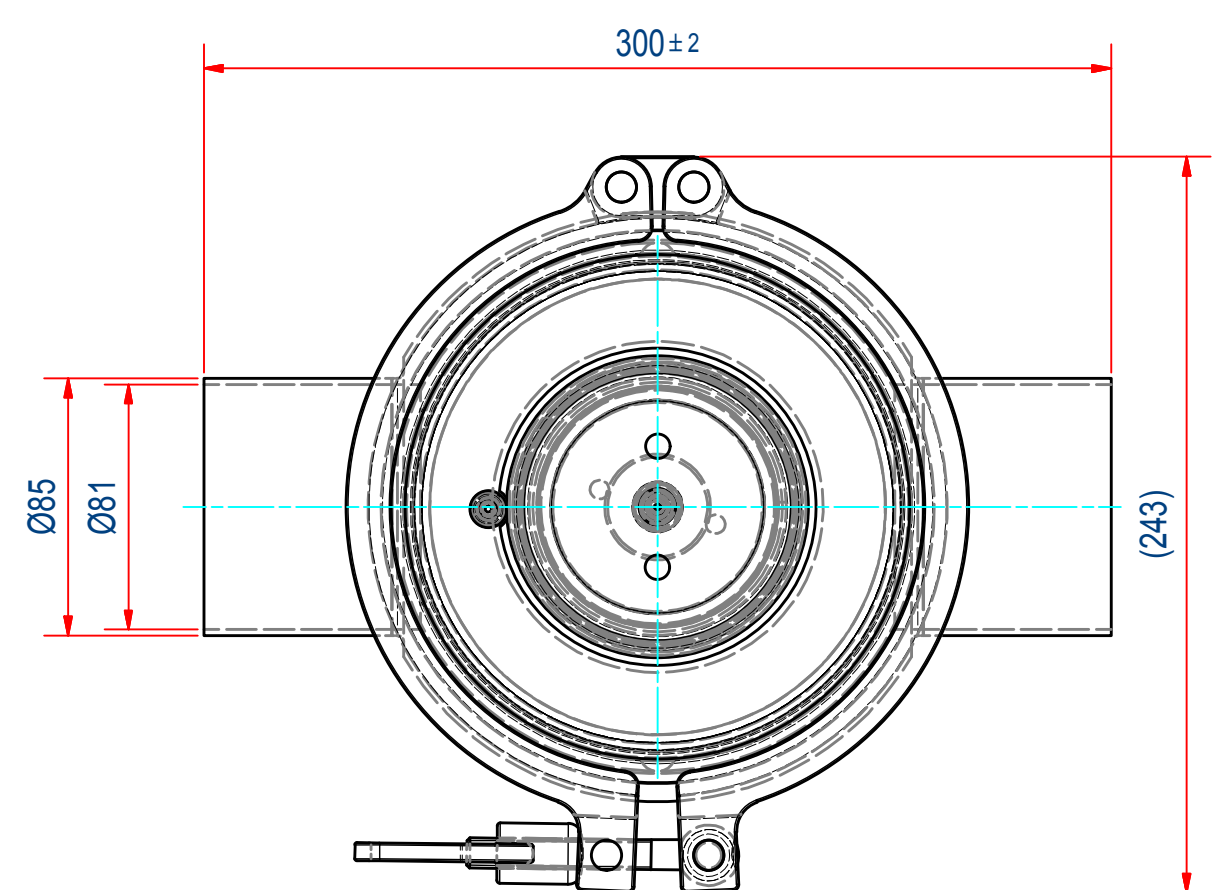
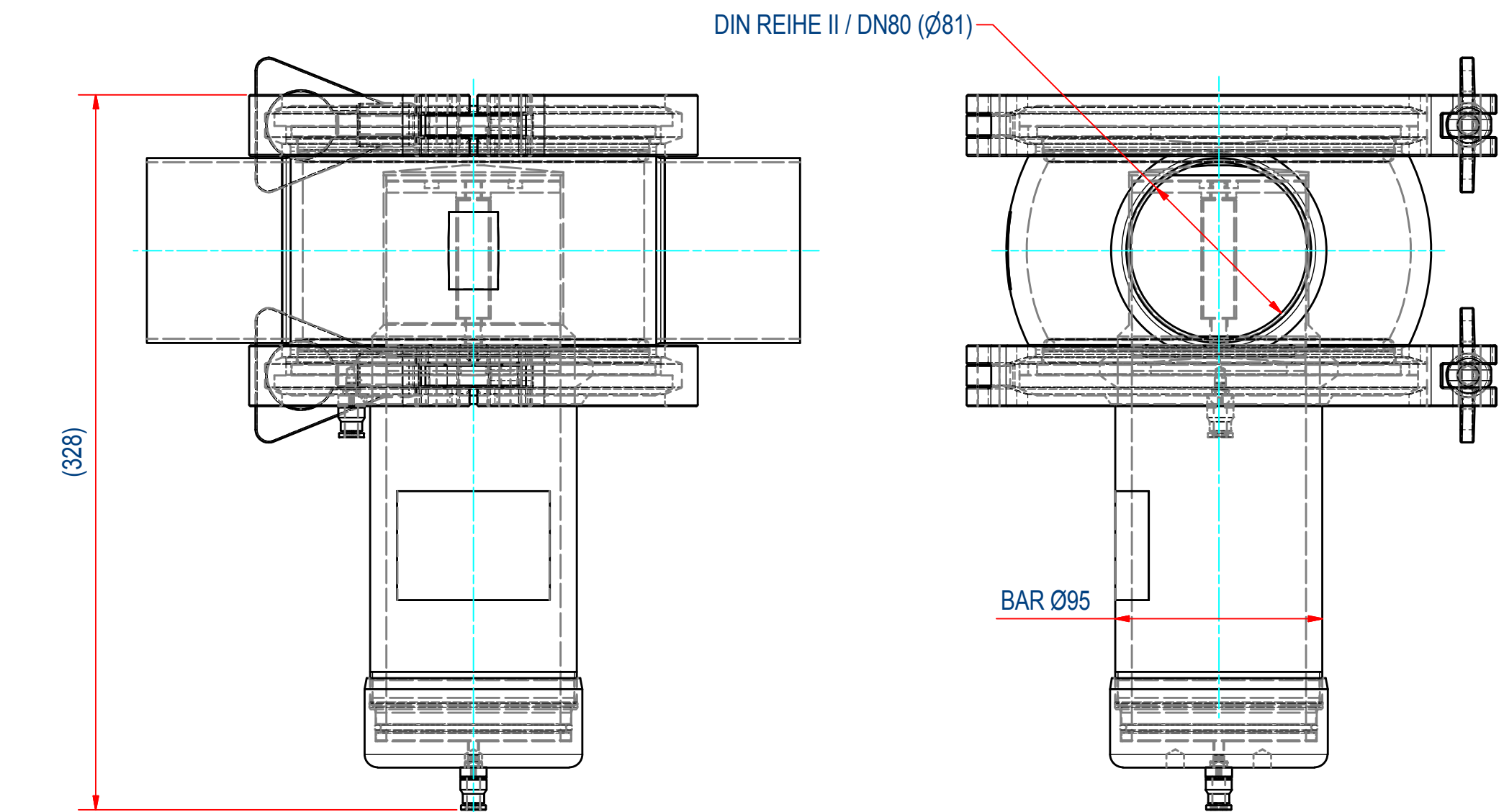

SYSTEM IS SUITABLE FOR CIP CLEANING

ITEM	QTY	PART NUMBER	DESCRIPTION	Dimensions
6	1	E0043423	STICK SFH ORNR+PARTNR+TESTNR	
5	1	E0043420	STICKER EHDG FILTER	
4	2	E0024419	O-RING 142,24x5,33 EC1935 EPDM	
3	1	E0016733	SFH-000 BOTTOM PLATE 316L	
2	1	E0020396	SFH-80 PNEUMATIC MAGNET BAR	
7	2	77.9630140	TRI-CLAMP DIN/ISO DN150 Ø183	
1	1	E0015744	HOUSE SFH-80-T1 316L	

RAW MAT.	QTY	MAT. NUMBER	MAT. DESCRIPTION	LENGTH (mm)	WIDTH (mm)
⊕	1				

Sheet: <b>A2</b>	Extra info:	General tolerance: <b>ISO 2768- mK</b>
Drawn: <b>AVD</b>	Weight (kg): <b>23,5</b>	Drawn according: <b>ISO268; ISO1101; ISO2553</b>
Date: <b>18-4-2014</b>		Status: <b>Standard</b>
Spare part: <b>False</b>		Customer reference number:
Quick search: <b>SFH-080</b>	<p>© All rights reserved. Reproduction is not permitted without written permission of GOUDSMIT Magnetic Systems BV</p>	File number: <b>E0015988</b>
Description: <b>SFH-080-T1-01R-HT-F5M-E-B-B</b>		Rev: <b>A</b>
		Part number: <b>E0015988</b>
		Rev: <b>A</b>