

REV	DATE	BY	DESCRIPTION
-	8-7-2014	AvD	REFERENCE DRAWING E0011932
A	9-7-2015	CR	NOTHING CHANGED

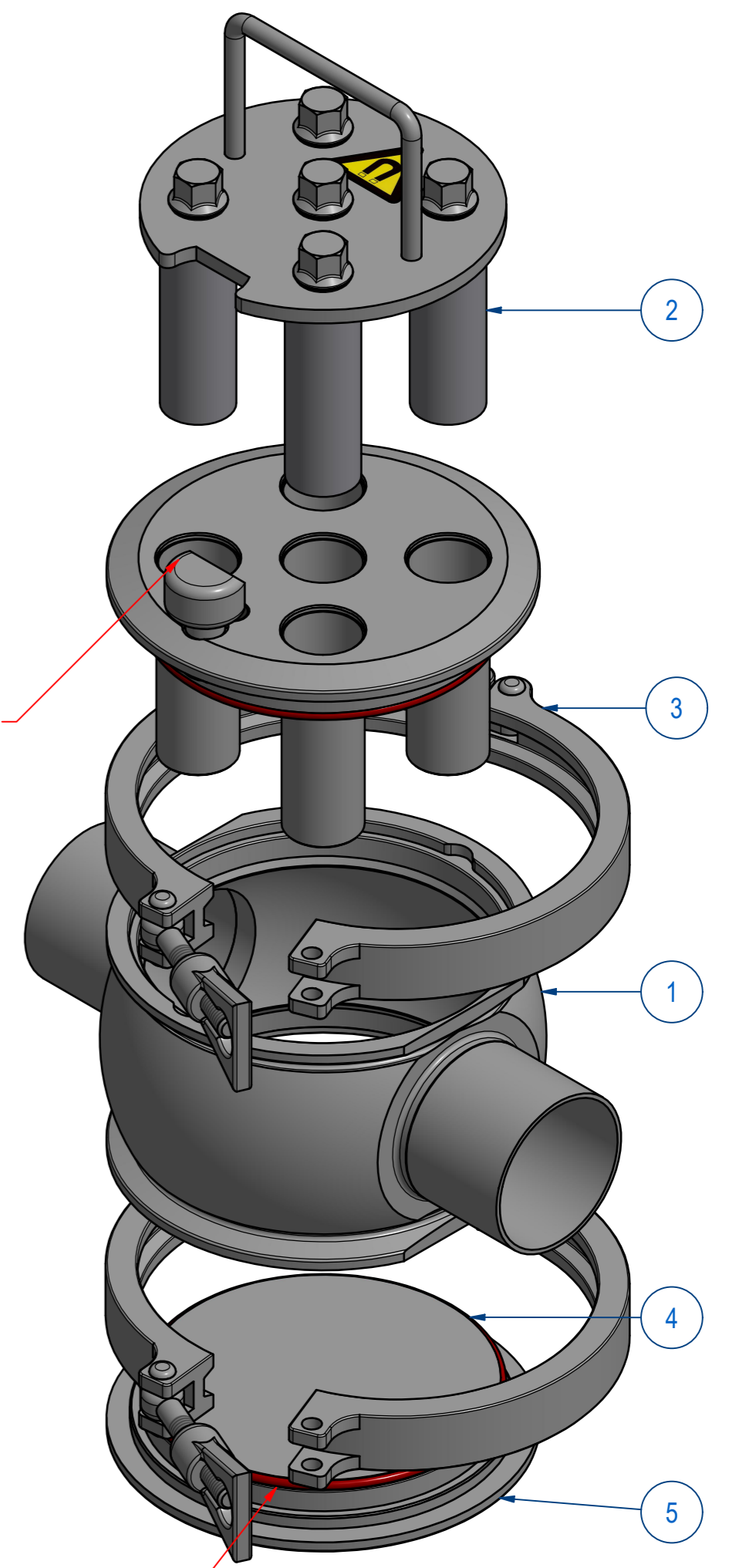

CLEANING PROTECTION

SEAL CONFORM TO HYGIENIC DESIGN

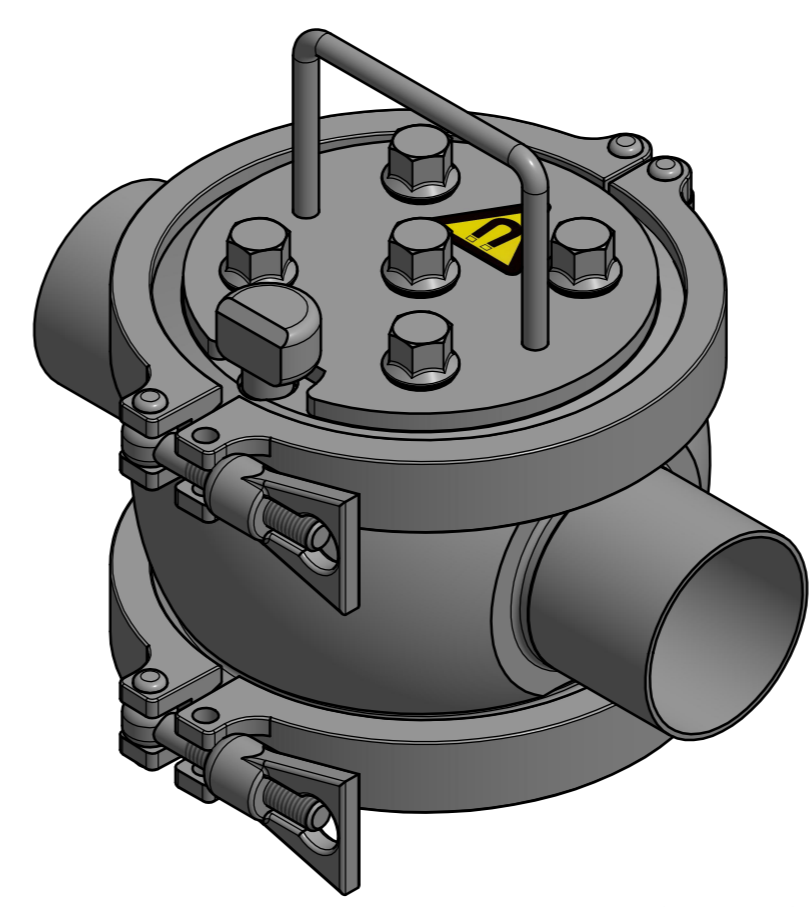
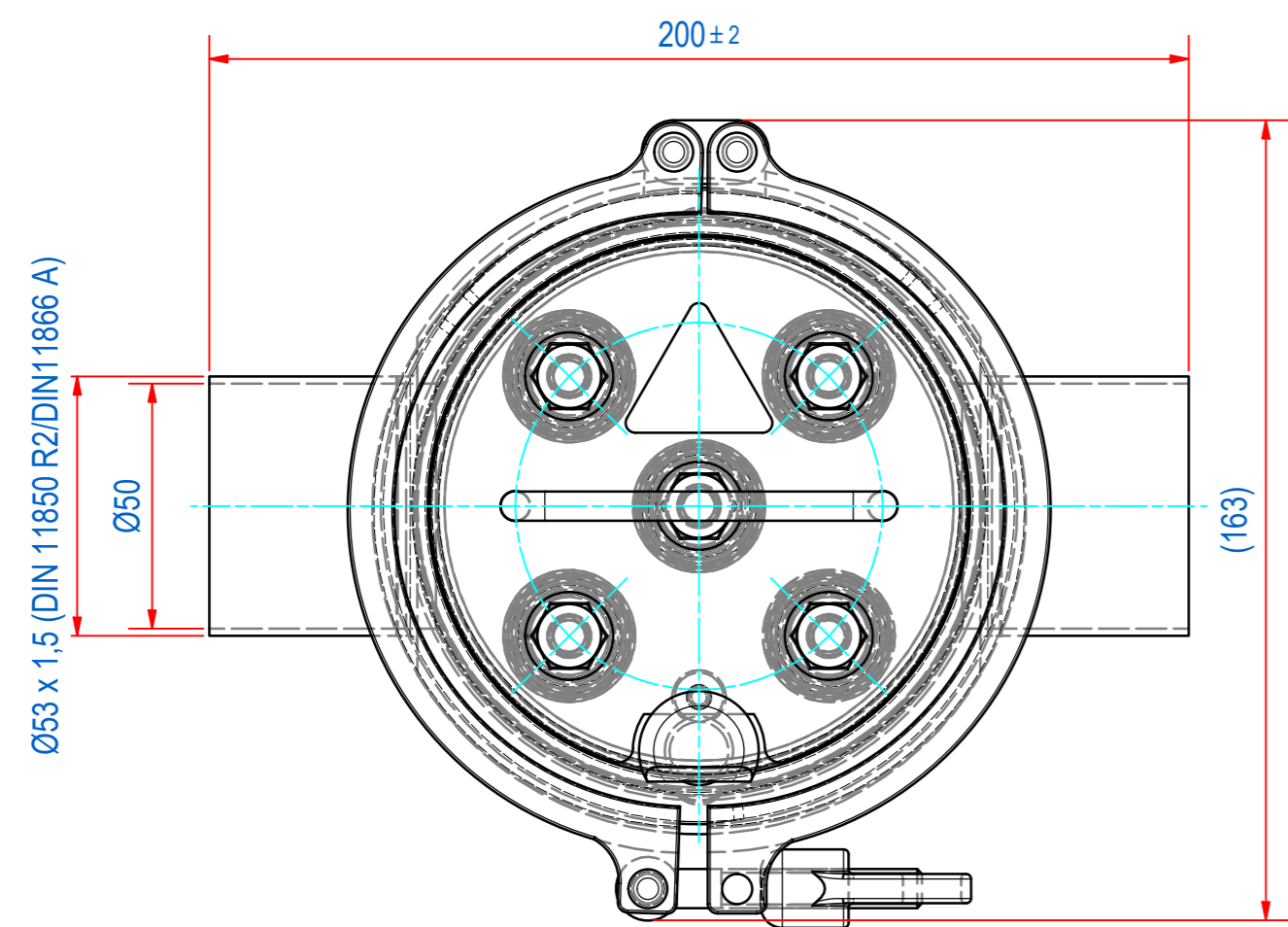
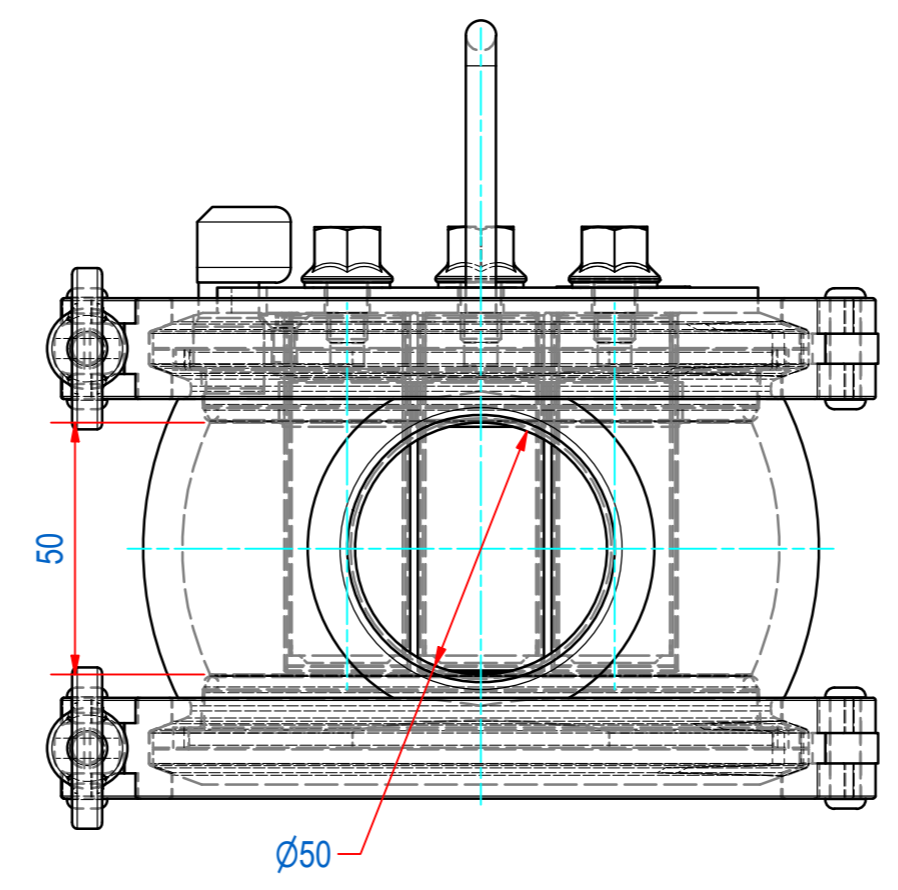
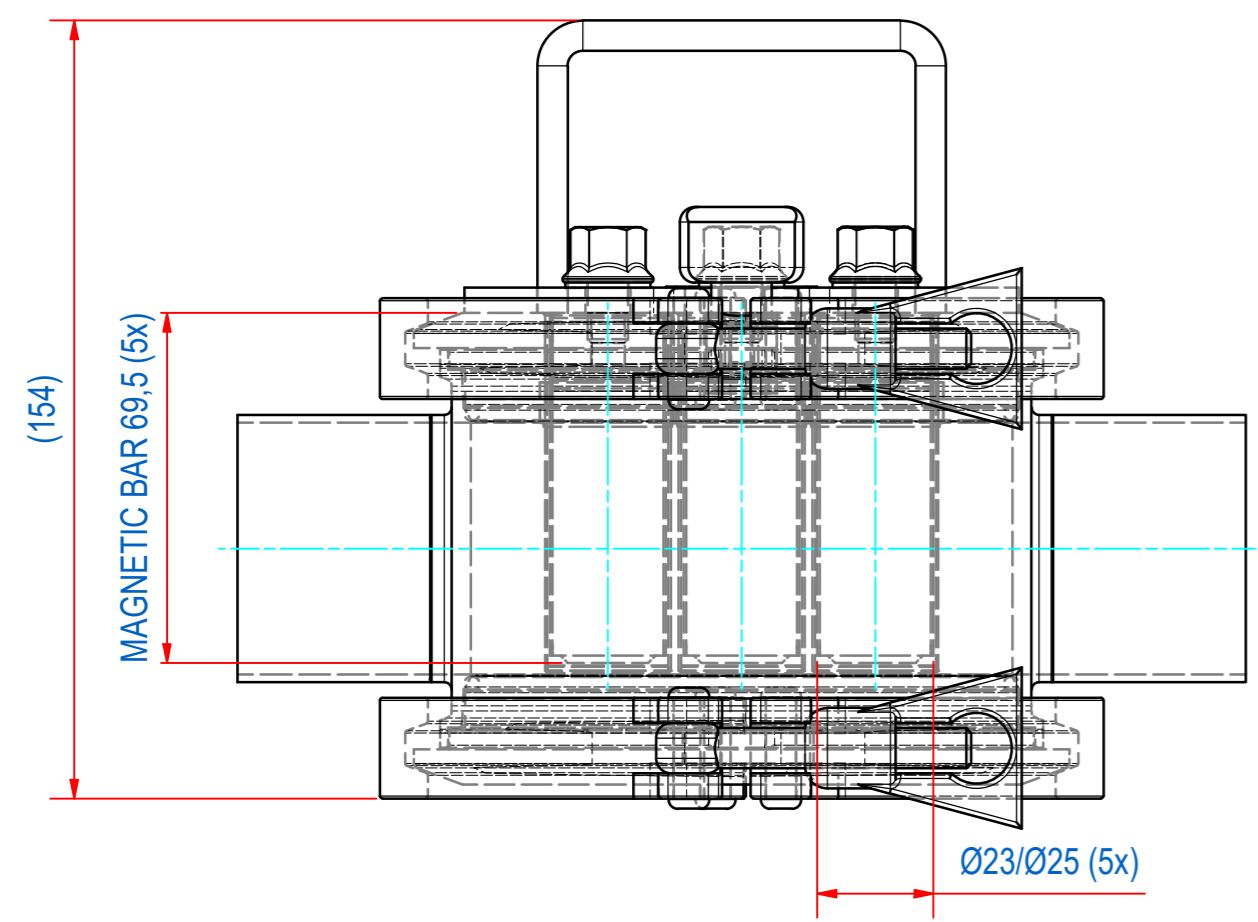

ITEM	QTY	PART NUMBER	DESCRIPTION	Dimensions
5	1	E0014904	SFH-000 BOTTOM PLATE 316L	
4	2	E0017388	SFH-S-000-S O-RING RED EC1935	
3	2	77.9630092	GPFI-TRI CLAMP D130	
2	1	E0012550	SFH-S-050-05E-HT INSERT	
1	1	E0013305	SFH-050-T1 HOUSE 316L	

RAW MAT.	Quantity	Material Number	Material Description	Length (mm)	Width (mm)
⊕	1				

Sheet: A2	Extra info:	General tolerance: ISO 2768 - mK
Drawn: AVD	Weight (kg): 7,8	Drawn according: ISO286; ISO1101; ISO2553
Date: 19-5-2014		Status: Standard
Spare part: False	Source:	Customer reference number:
Quick search: SFH-050		Document number: E0016970
Description: SFH-050-T1-05E-HT-F5M-S-B-B-B		Doc.Rev: A
		Part number: E0016970
		Rev: A



© All rights reserved. Reproduction is not permitted without written permission of GOUDSMIT Magnetic Systems BV