

REV	DATE	BY	DESCRIPTION
-	8-7-2014	AvD	REFERENCE DRAWING E0014903
A	12-8-2016	CR	GASKETS CHANGED: EPDM WAS SILICONE AND EHEDGE AND TYPE PLATE ADDED
B	30-11-2017	AvD	DESIGN OF MAGNETIC BAR CHANGED

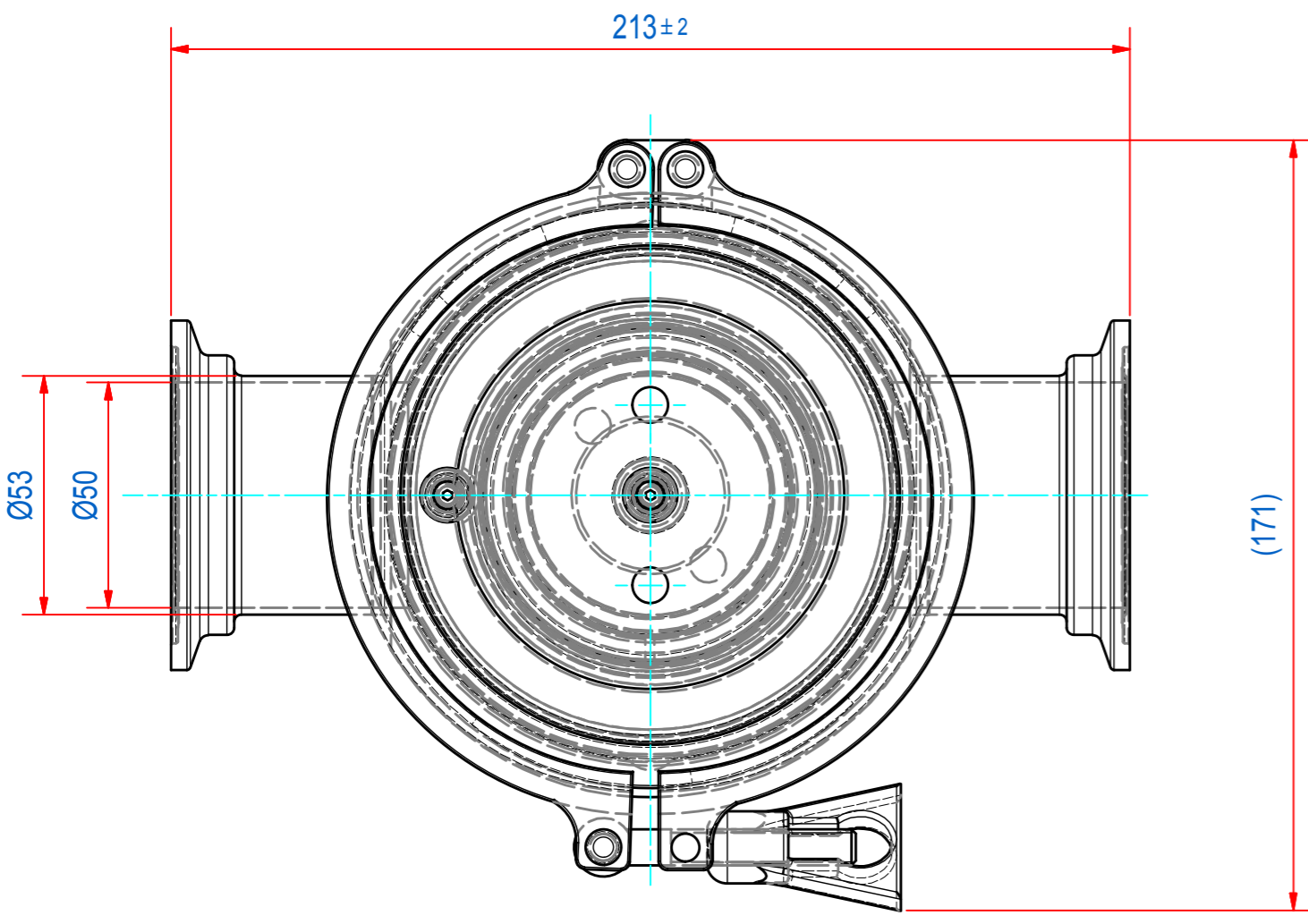
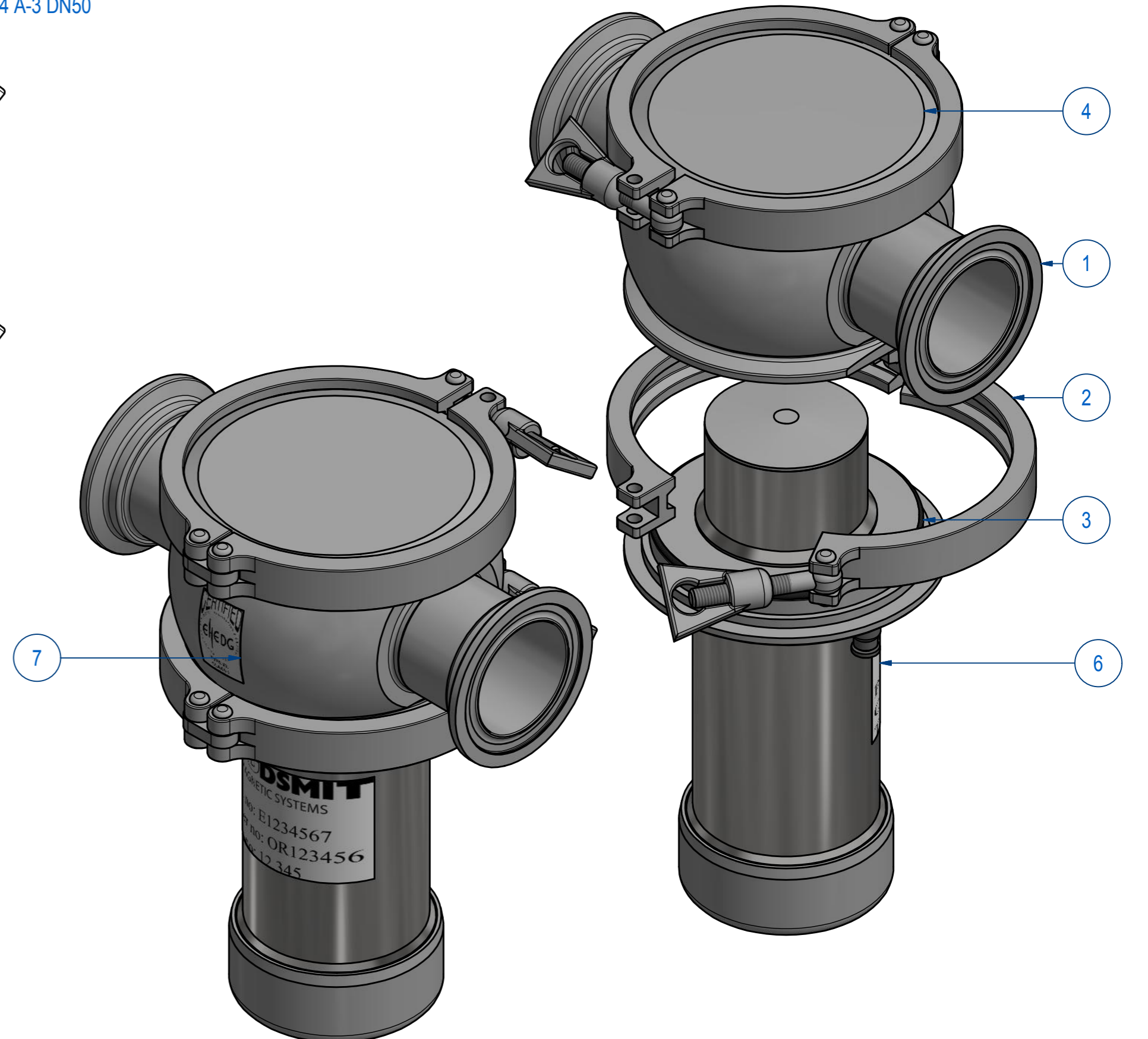
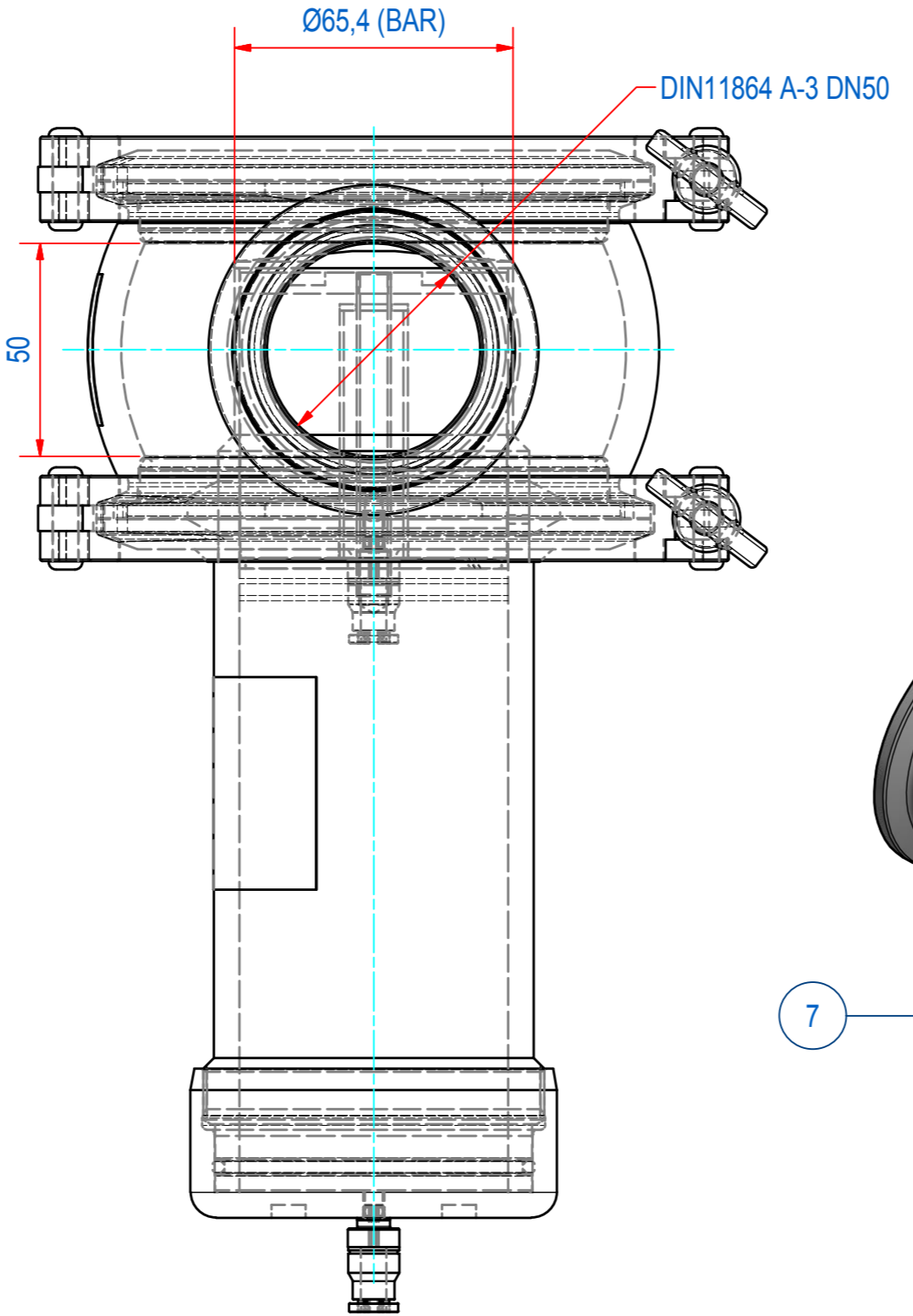
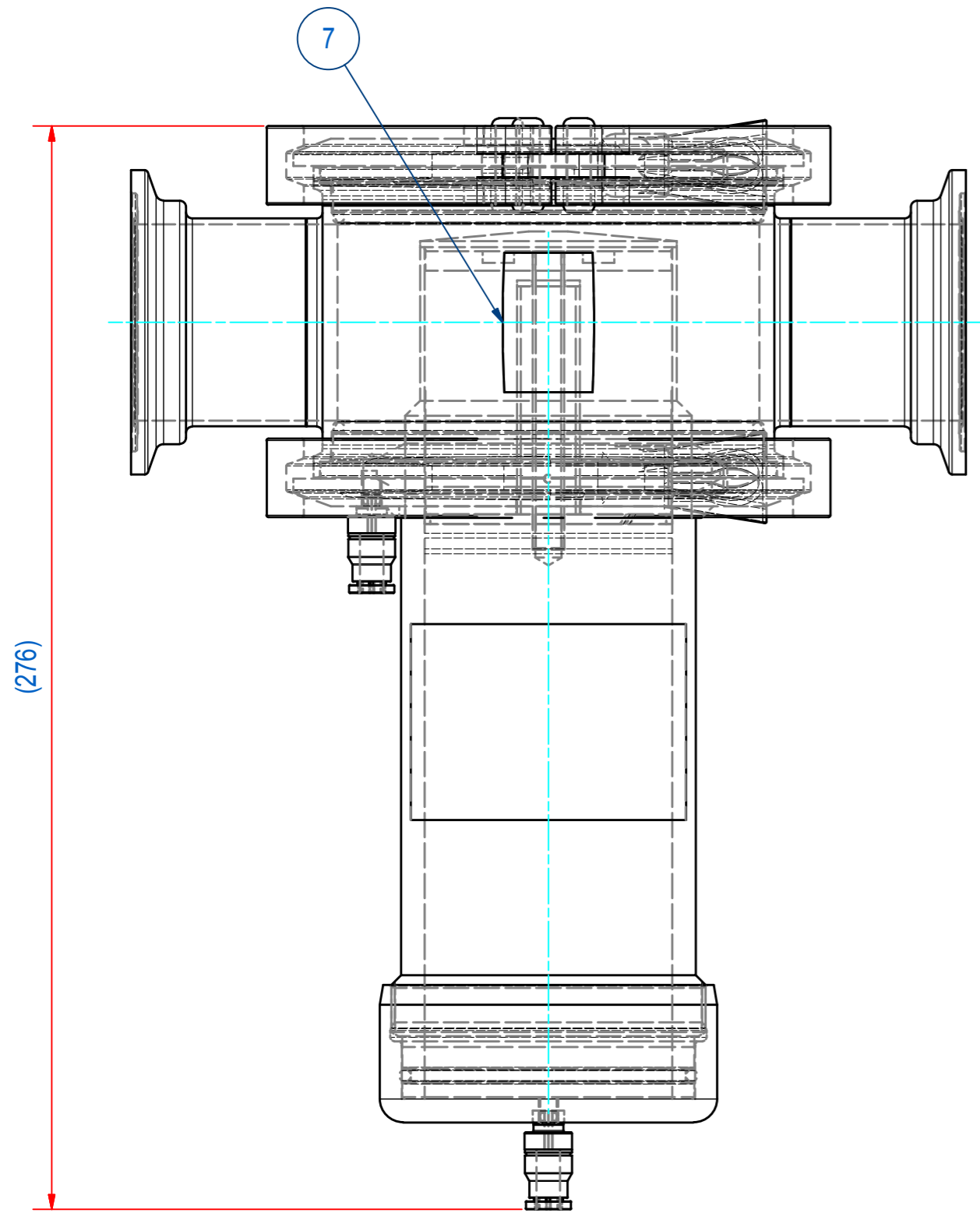

SYSTEM IS SUITABLE FOR CIP CLEANING

ITEM	QTY	PART NUMBER	DESCRIPTION	Dimensions
7	1	E0043358	STICKER EHEDG FILTER	
6	1	E0043413	STICK SFH ORNR+PARTNR+TESTNR	
5	1	E0017054	SFH-50 PNEUMATIC MAGNET BAR	
4	1	E0014904	SFH-50 BOTTOM PLATE 316L	
3	2	E0024248	O-RING Ø96xØ3 EC1935 EPDM	
2	2	77.9630092	CLAMP LIGHT ISO-2852 4.5"	
1	1	E0011836	SFH-50-HOUSE-PC 316L	

RAW MAT.	QTY	MAT. NUMBER	MAT. DESCRIPTION	LENGTH (mm)	WIDTH (mm)
Sheet:	A2	Extra info:	MAGNETIC FILTER	General tolerance:	ISO 2768- mK
Drawn:	AVD	Weight (kg):	10,3	Drawn according:	ISO268; ISO1101; ISO2553
Date:	5-6-2014	Status:	Standard	Customer reference number:	
Spare part:	False	File number:	E0086701	Rev:	B
Quick search:	SFH-050	Description:	SFH-050-PC-01R-HT-F5M-E-B-B	Part number:	E0017392
				Rev:	B



© All rights reserved. Reproduction is not permitted without written permission of GOUDSMIT Magnetic Systems BV