

REV	DATE	BY	DESCRIPTION
-	21-8-2014	AvD	REFERENCE DRAWING E0011932

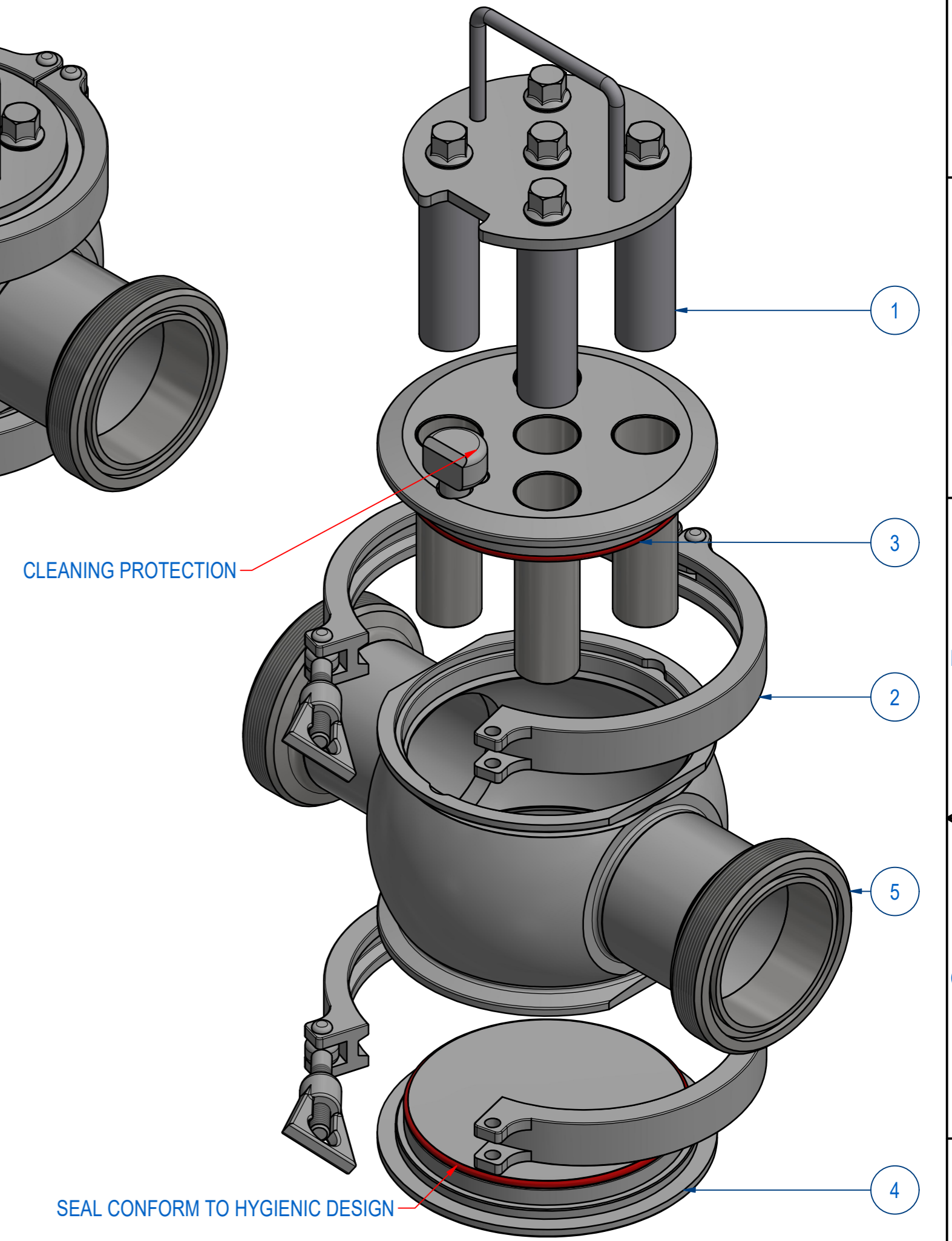
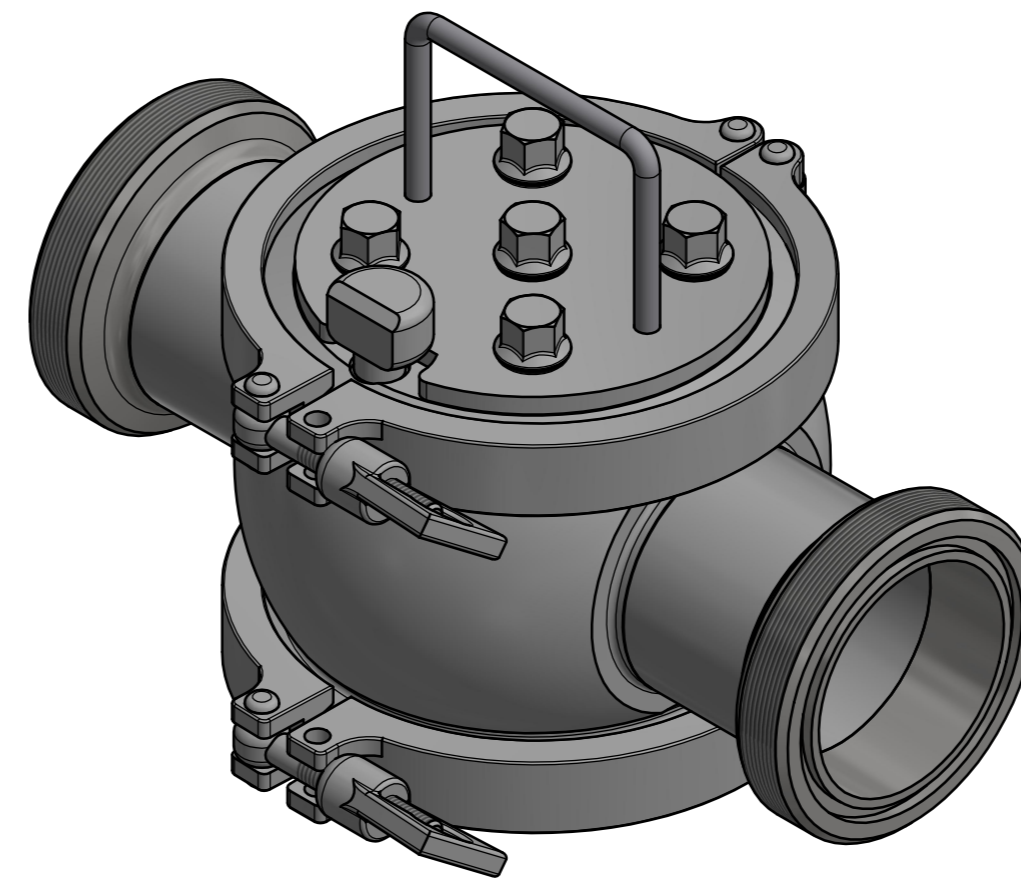
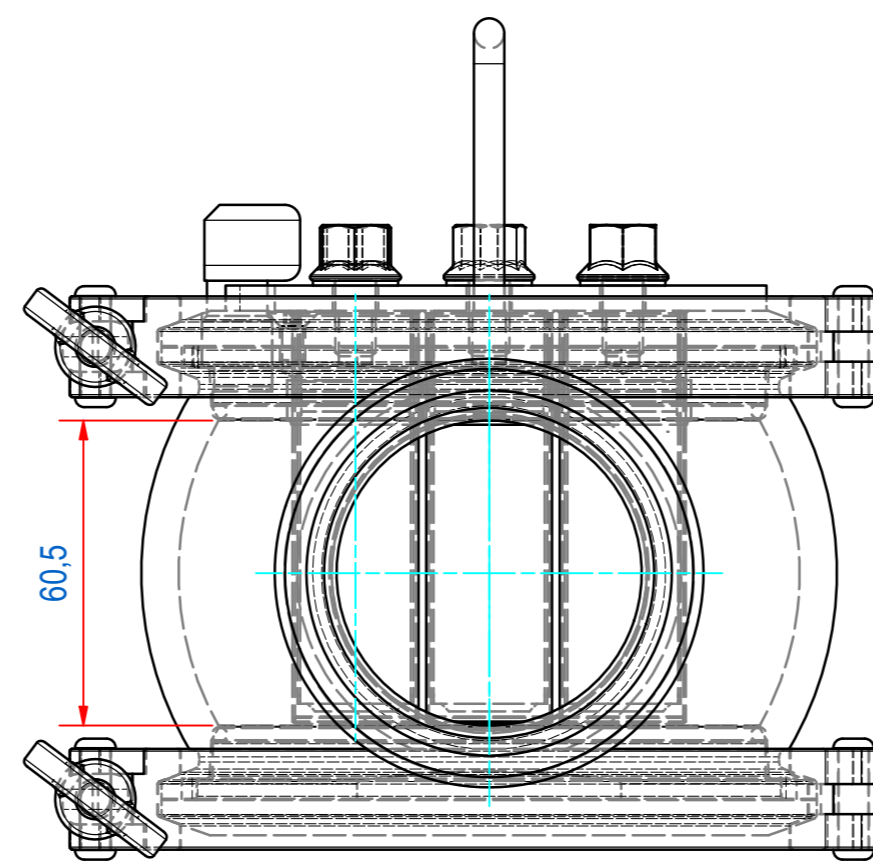
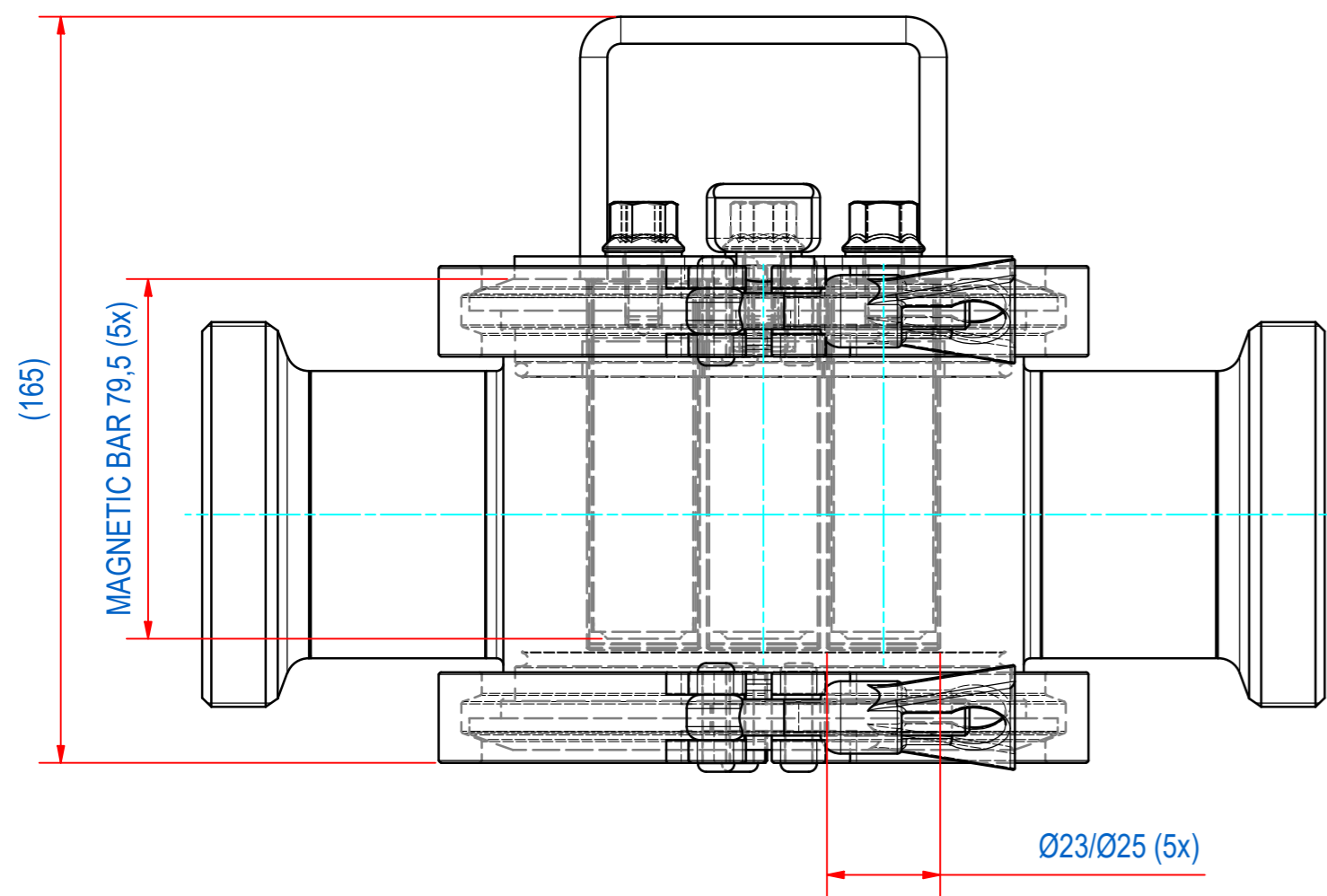
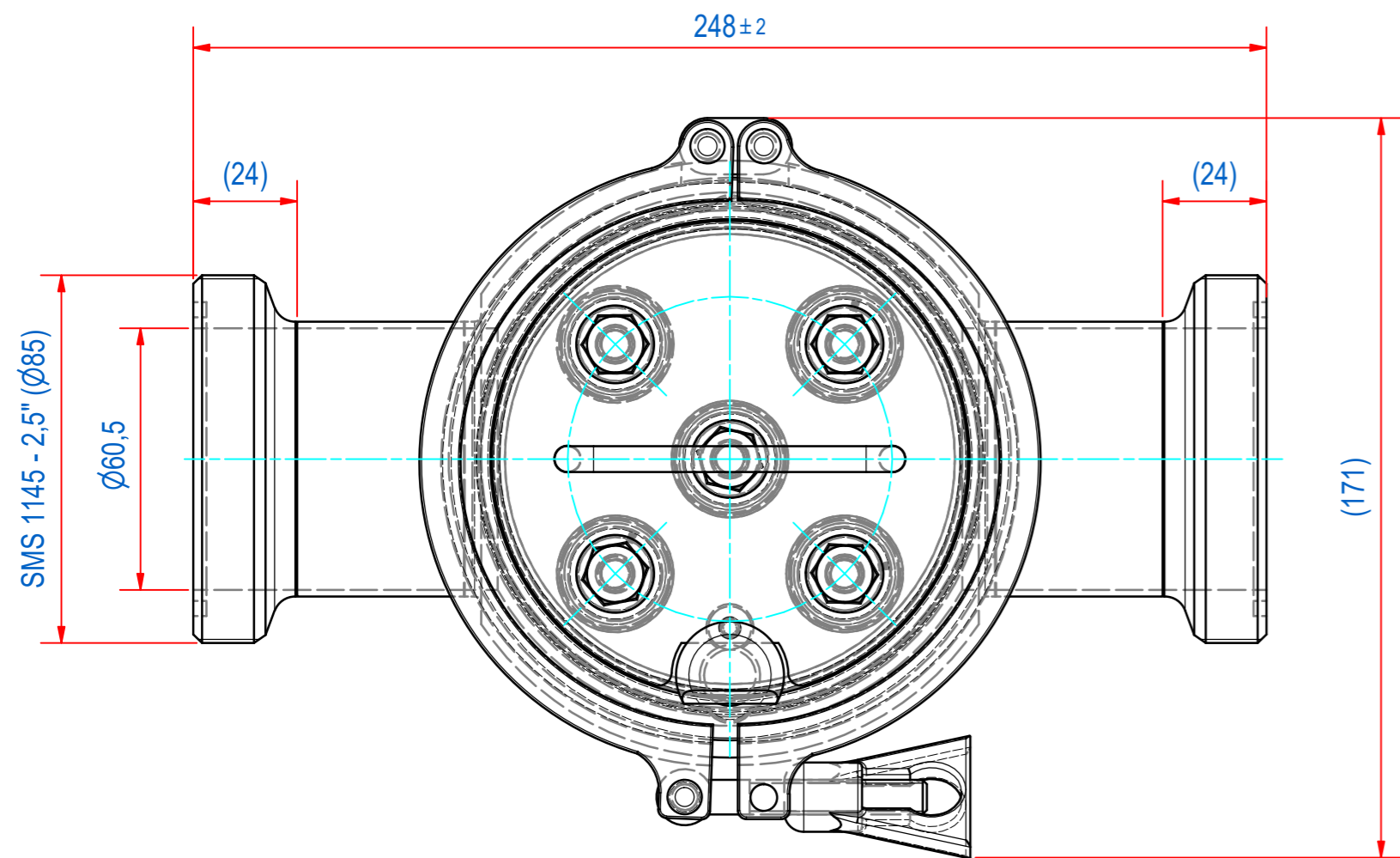

ITEM	QTY	PART NUMBER	DESCRIPTION	Dimensions
5	1	E0020361	SFH-2.5" SMS1145 HOUSE 316L	
4	1	E0014904	SFH-50 BOTTOM PLATE 316L	
3	2	E0017388	O-RING Ø104x3 EC1935 SILIC. RED	
2	2	77.9630092	CLAMP LIGHT ISO-2852 4.5"	
1	1	E0020375	SFH-SPARE-2.5"-05E-HT FILTER TOP	

RAW MAT.	Quantity	Material Number	Material Description	Length (mm)	Width (mm)
⊕	1				

Sheet:	A2	Extra info:	MAGNETIC FILTER	General tolerance:	ISO 2768 - mK
Drawn:	AVD	Weight (kg):	8,9	Drawn according:	ISO268; ISO1101; ISO2553
Date:	19-8-2014			Status:	Released
Spare part:	False			Customer reference number:	
Quick search:	SFH-2.5"			Document number:	E0020362
Description:	SFH-2.5"-ST-05E-HT-F5M-S-B-B-B			Part number:	E0020362



© All rights reserved. Reproduction is not permitted without written permission of GOUDSMIT Magnetic Systems BV