

REV	DATE	BY	DESCRIPTION
-	22-8-2014	AvD	ORIGINAL DRAWING
A	30-11-2017	AvD	DESIGN OF MAGNETIC BAR CHANGED

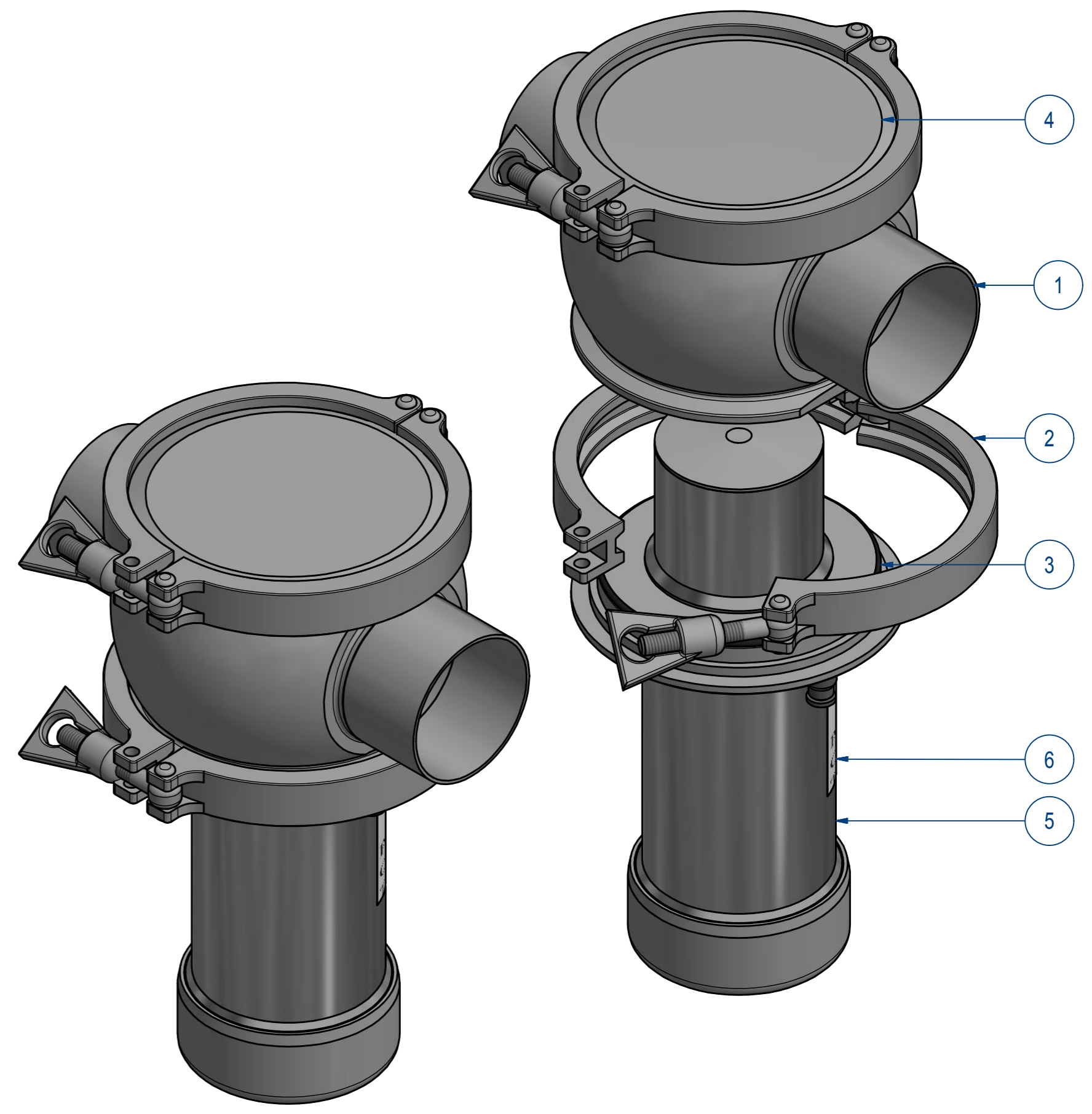
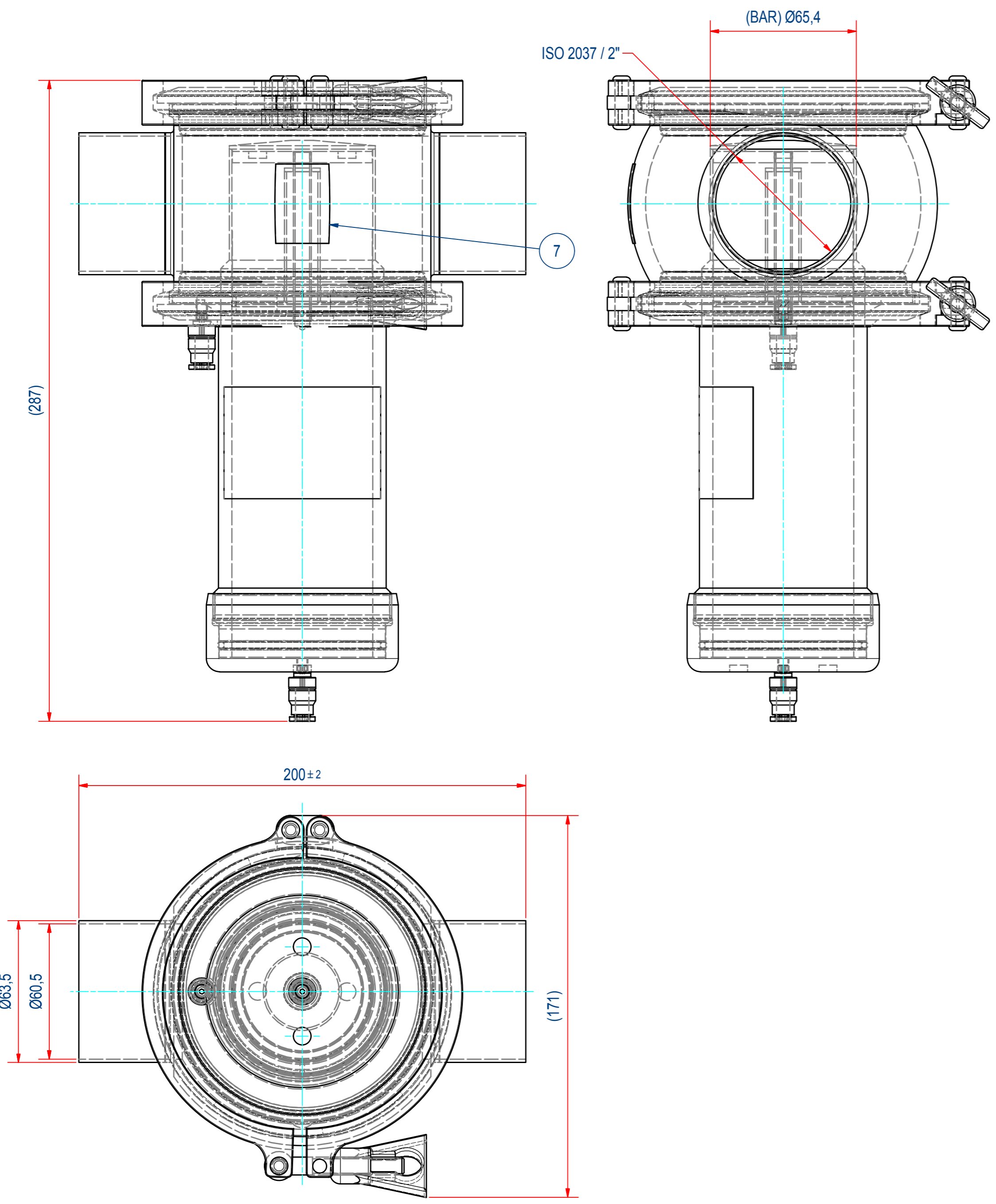

SYSTEM IS SUITABLE FOR CIP CLEANING

ITEM	QTY	PART NUMBER	DESCRIPTION	Dimensions
7	1	E0045608	STICKER EHEDG FILTER	
6	1	E0043413	STICK SFH ORNR+PARTNR+TESTNR	
5	1	E0020444	SFH-2.5" PNEUMATIC MAGNET BAR	
4	1	E0014904	SFH-50 BOTTOM PLATE 316L	
3	2	E0024248	O-RING Ø96xØ3 EC1935 EPDM	
2	2	77.9630092	CLAMP LIGHT ISO-2852 4.5"	
1	1	E0016306	SFH-2,5" Ø63,5 x 1,5 HOUSE 316L	

RAW MAT.	QTY	MAT. NUMBER	MAT. DESCRIPTION	LENGTH (mm)	WIDTH (mm)
	1				

Sheet: A2	Extra info: MAGNETIC FILTER	General tolerance: ISO 2768 - mK
Drawn: AVD	Weight (kg): 10,2	Drawn according: ISO268; ISO1101; ISO2553
Date: 22-8-2014		Status: Standard
Spare part: False		Customer reference number:
Quick search: SFH-2.5"	© All rights reserved. Reproduction is not permitted without written permission of GOUDSMIT Magnetic Systems BV	File number: E0086697
Description: SFH-2.5"-T2-01R-HT-F5M-E-B-B		Part number: E0020440