

REV	DATE	BY	DESCRIPTION
-	4-9-2014	AvD	REFERENCE DRAWING E0015988
A	5-8-2016	CR	O-RING CHANGED: EPDM WAS SILICONE

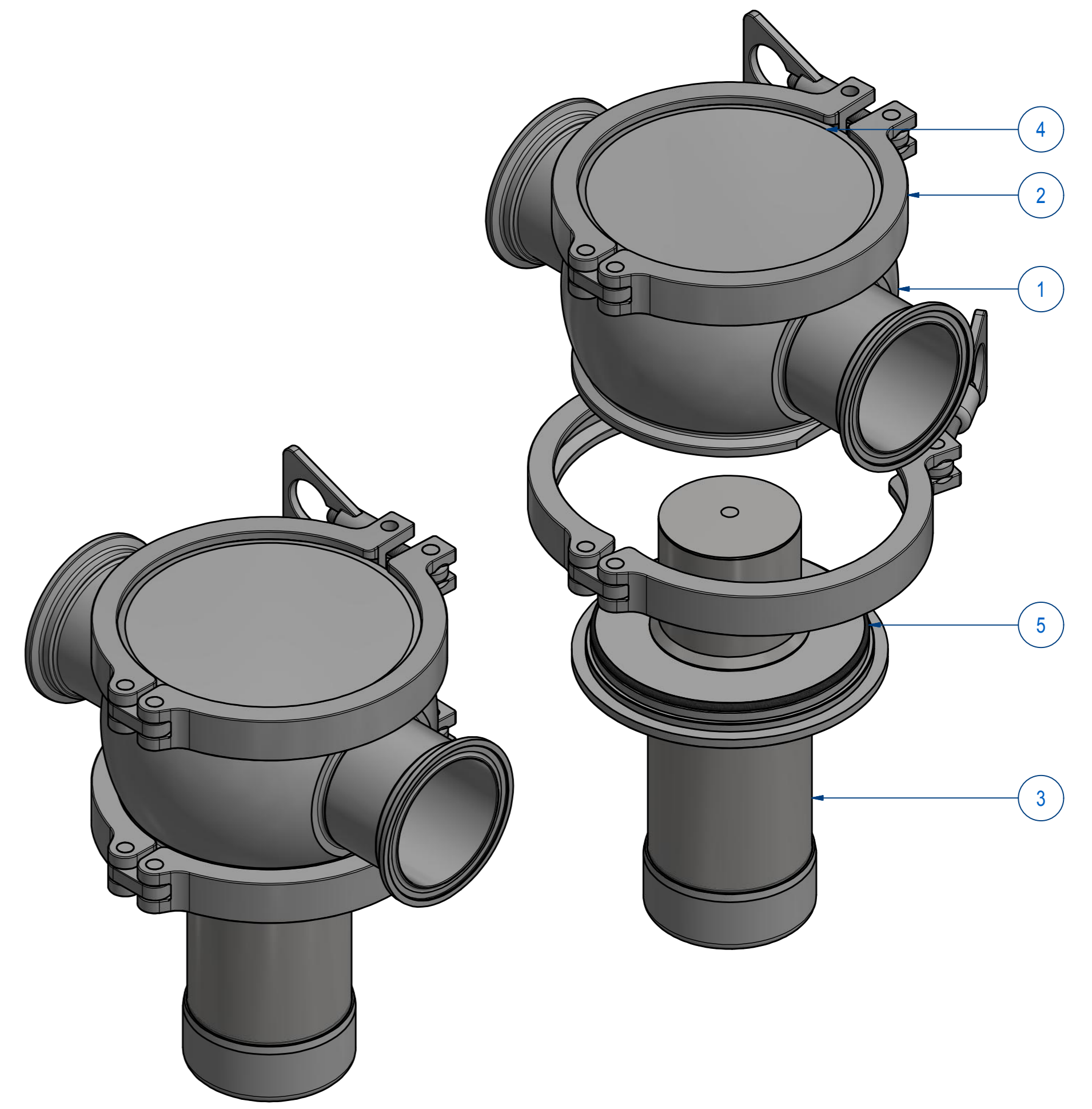
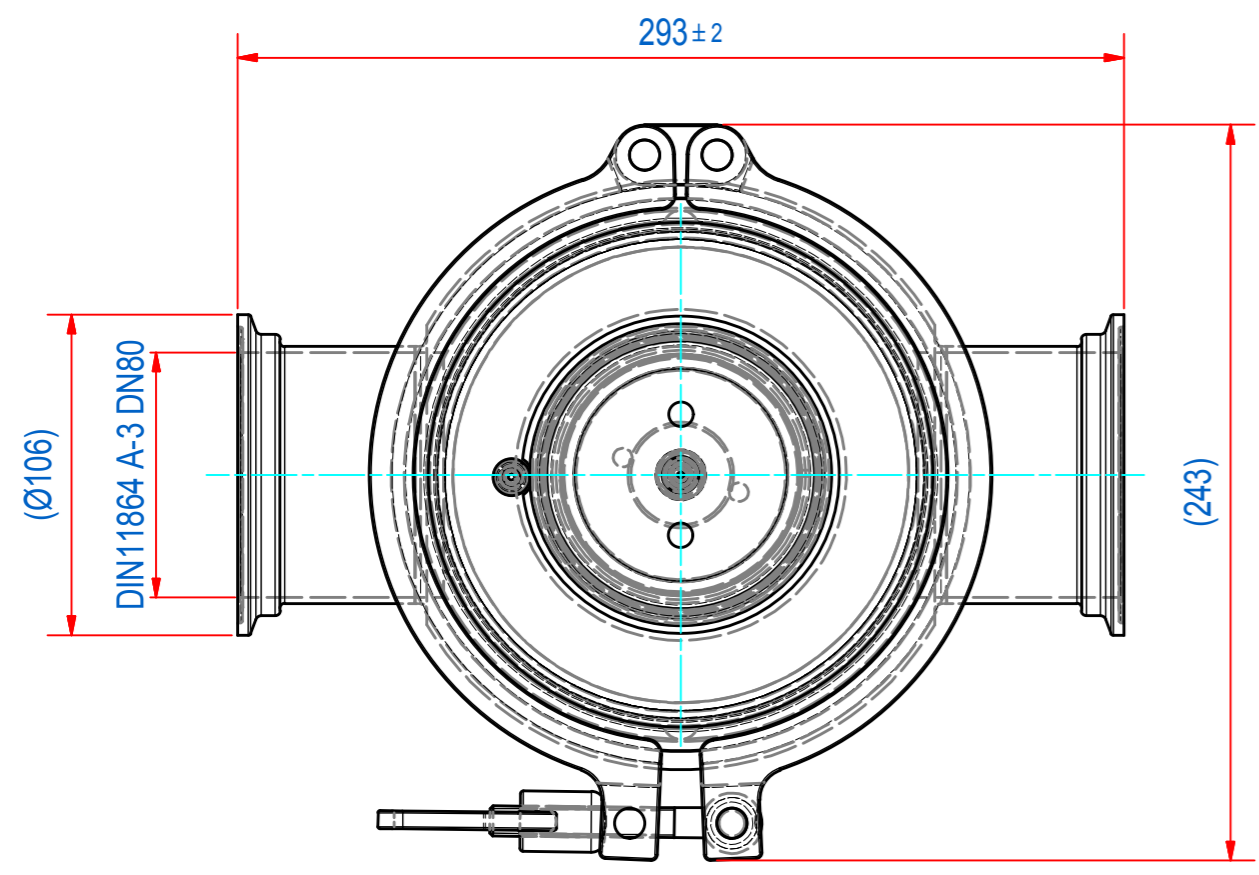
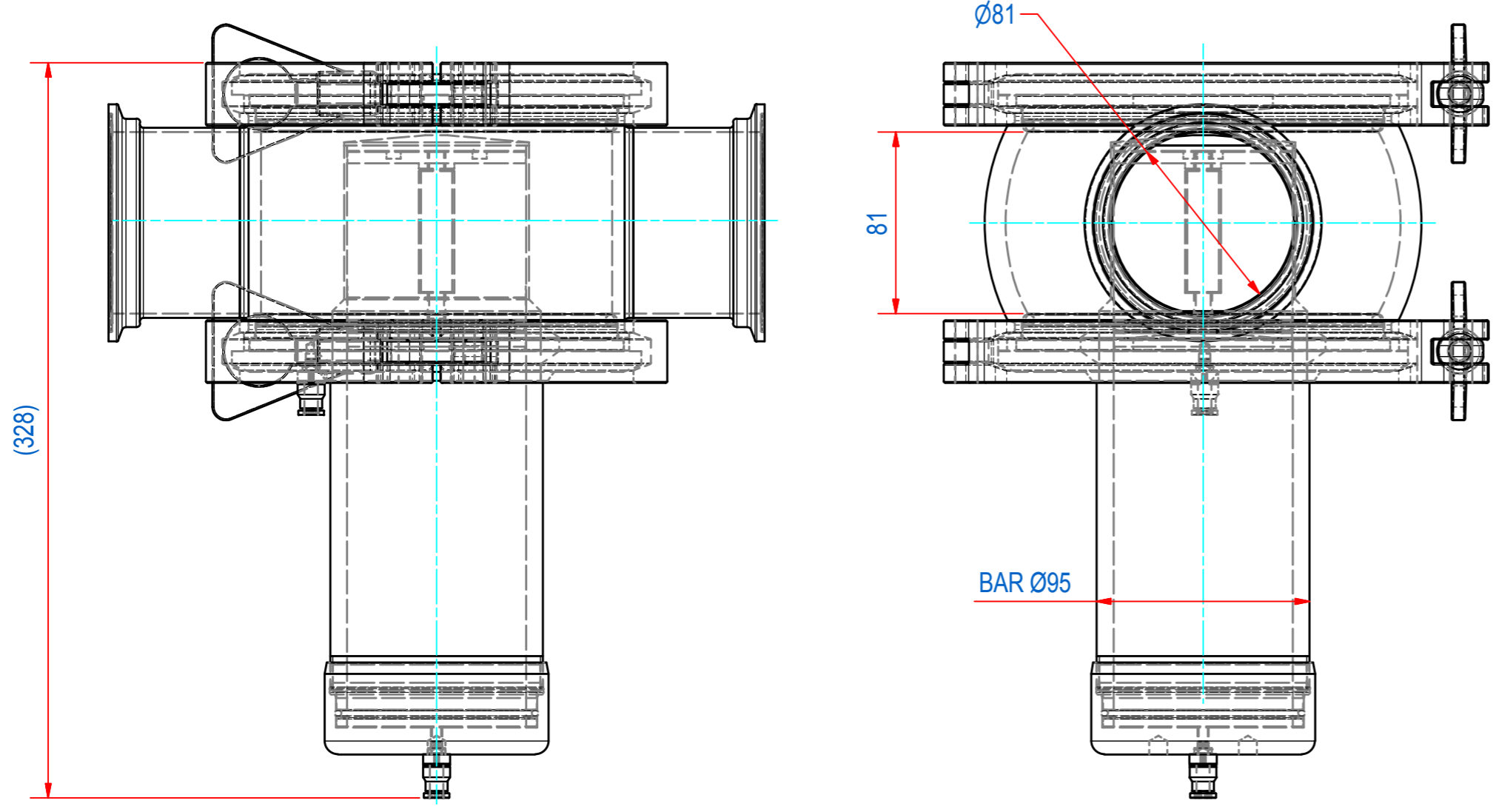

SYSTEM IS SUITABLE FOR CIP CLEANING

ITEM	QTY	PART NUMBER	DESCRIPTION	Dimensions
5	2	E0024419	O-RING 142,24x5,33 EC1935 EPDM	
4	1	E0016733	SFH-000 BOTTOM PLATE 316L	
3	1	E0020396	SFH-80 PNEUMATIC MAGNET BAR	
2	2	77.9630140	TRI-CLAMP DIN/ISO DN150 Ø183	
1	1	E0018611	SFH-80 DIN11864 A-3 HOUSE 316L	

RAW MAT.	QTY	MAT. NUMBER	MAT. DESCRIPTION	LENGTH (mm)	WIDTH (mm)
⊕	1				

Sheet: A2	Extra info:	General tolerance: ISO 2768- mK
Drawn: AVD	Weight (kg): 23,5	Drawn according: ISO268; ISO1101; ISO2553
Date: 4-9-2014		Status: Standard
Spare part: False		Customer reference number:
Quick search: SFH-080	<p>© All rights reserved. Reproduction is not permitted without written permission of GOUDSMIT Magnetic Systems BV</p>	File number: E0021040
Description: SFH-080-PC-01R-HT-F5M-S-B-B		Part number: E0021040