

REV	DATE	BY	DESCRIPTION
-	5-9-2014	AvD	REFERENCE DRAWING E0015988
A	23-2-2016	CR	EHDG LOGO AND NAME PLATE ADDED O-RING CHANGED: EPDM WAS SILICONE

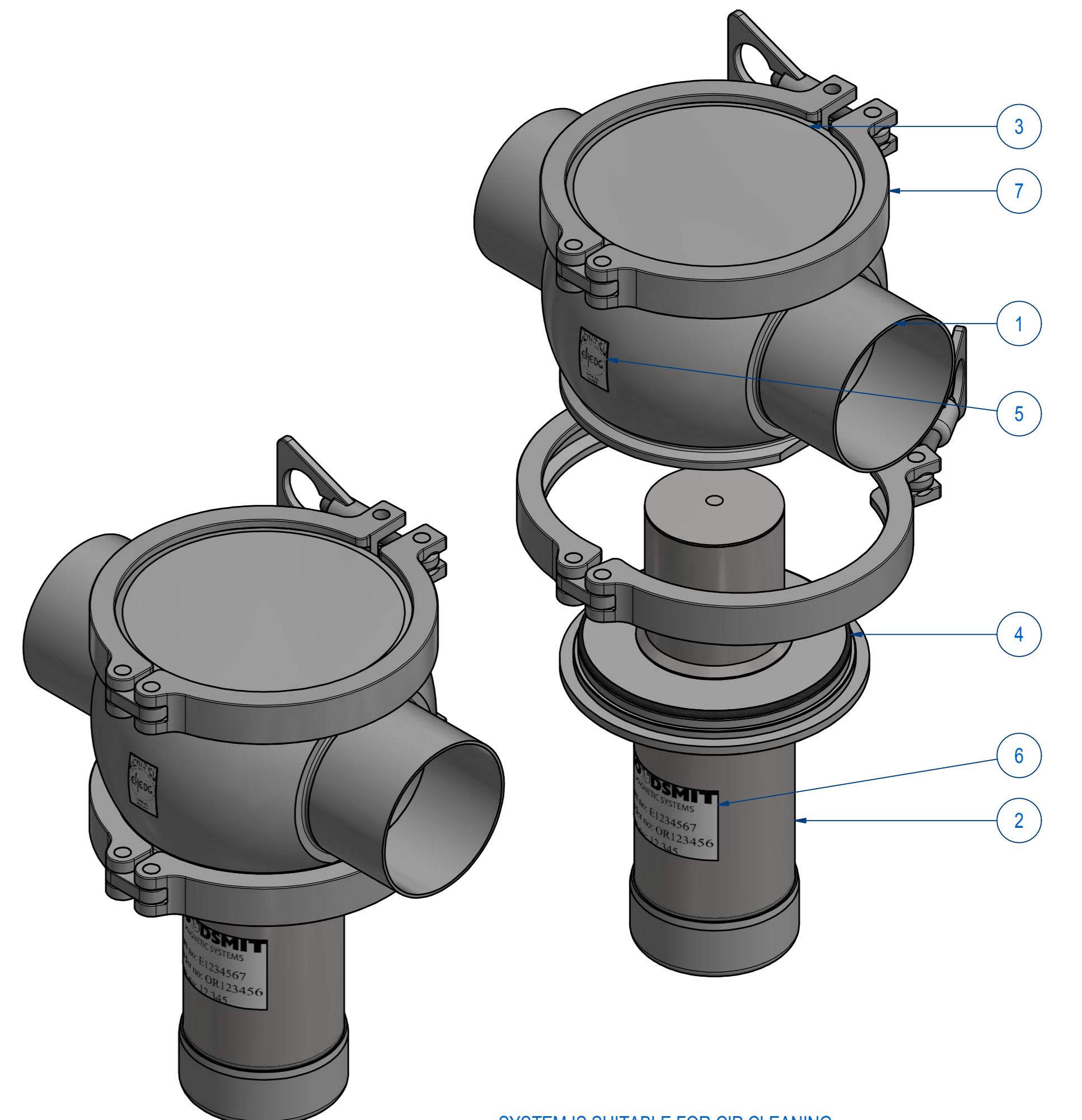
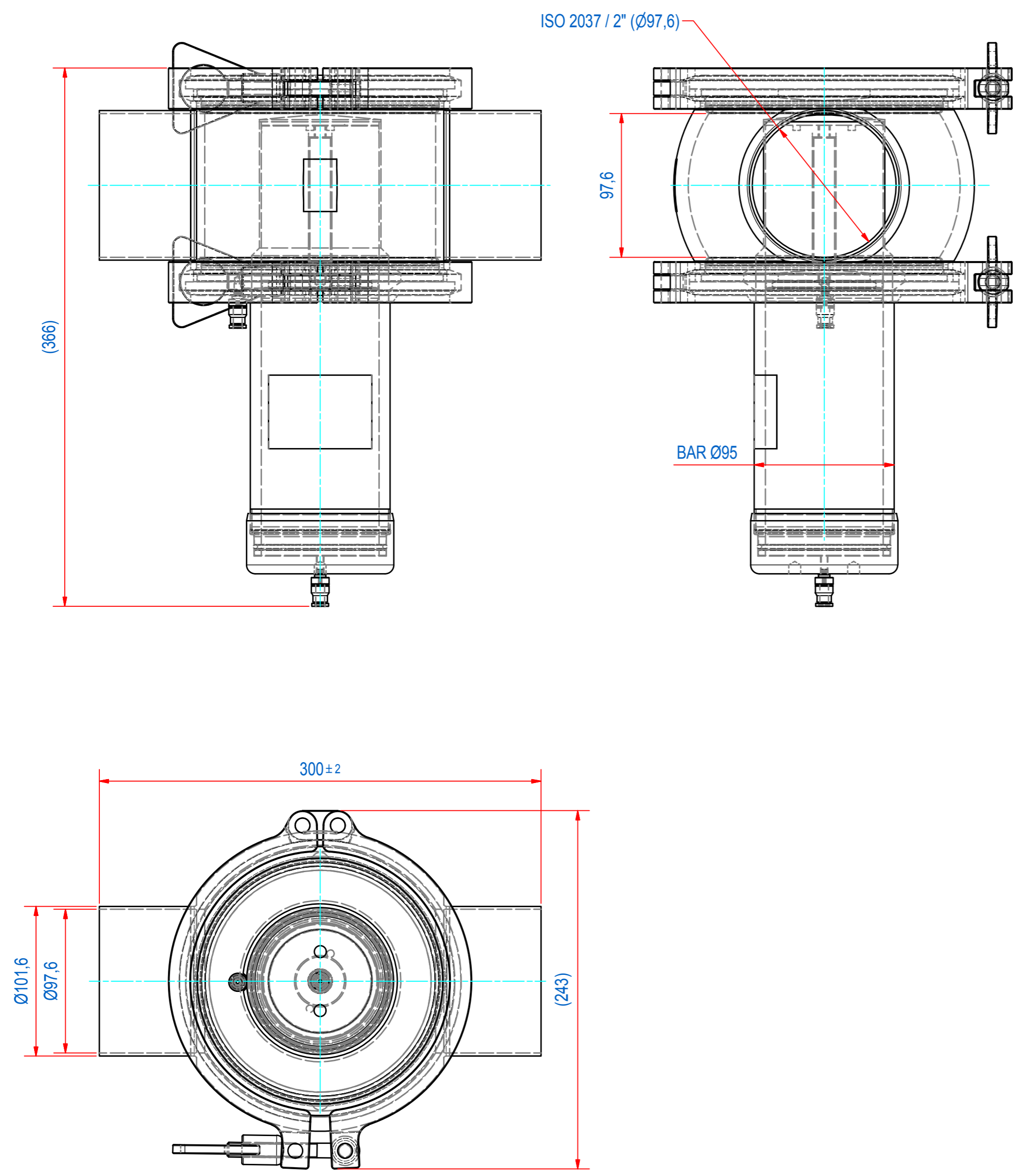

SYSTEM IS SUITABLE FOR CIP CLEANING

ITEM	QTY	PART NUMBER	DESCRIPTION	Dimensions
7	2	77.9630140	TRI-CLAMP DIN/ISO DN150 Ø183	
6	1	E0043423	STICK SFH ORNR+PARTNR+TESTNR	
5	1	E0043420	STICKER EHEDG FILTER	
4	2	E0024419	O-RING 142,24x5,33 EC1935 EPDM	
3	1	E0016733	SFH-000 BOTTOM PLATE 316L	
2	1	E0021075	SFH-4" PNEUMATIC MAGNET BAR	
1	1	E0019379	SFH-4" Ø101,6 x 2 HOUSE 316L	

RAW MAT.	QTY	MAT. NUMBER	MAT. DESCRIPTION	LENGTH (mm)	WIDTH (mm)
	1				

Sheet: A2	Extra info:	General tolerance: ISO 2768 - mK
Drawn: AVD	Weight (kg): 25,4	Drawn according: ISO268; ISO1101; ISO2553
Date: 5-9-2014		Status: Standard
Spare part: False		Customer reference number:
Quick search: SFH-4"	<p>© All rights reserved. Reproduction is not permitted without written permission of GOUDSMIT Magnetic Systems BV</p>	File number: E0021076
Description: SFH-4"-T2-01R-HT-F5M-E-B-B		Part number: E0021076