

REV	DATE	BY	DESCRIPTION
-	10-12-2014	TD	Reference drawing = E0025957
A	14-9-2016	DD	NEW SHELL, PRODUCT KEY CHANGED

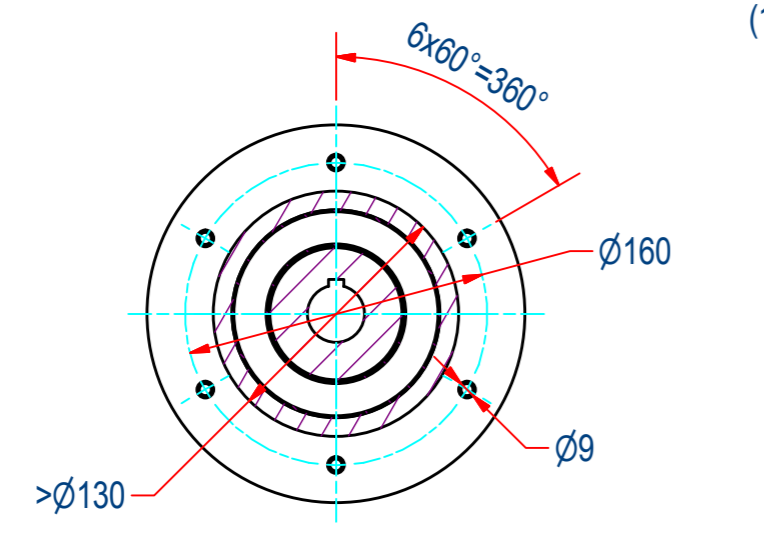

F-F  
MOUNTING DETAIL (2x)  
HOLE PATTERN COUNTER PART

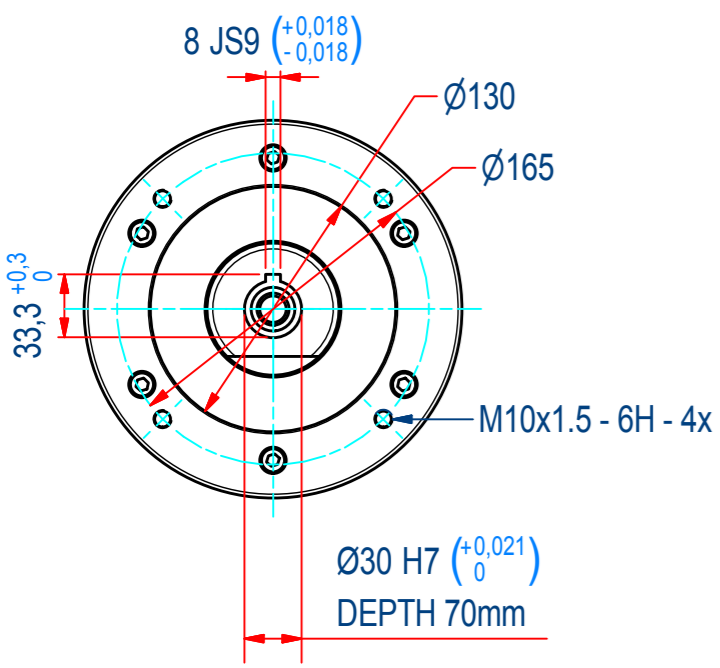
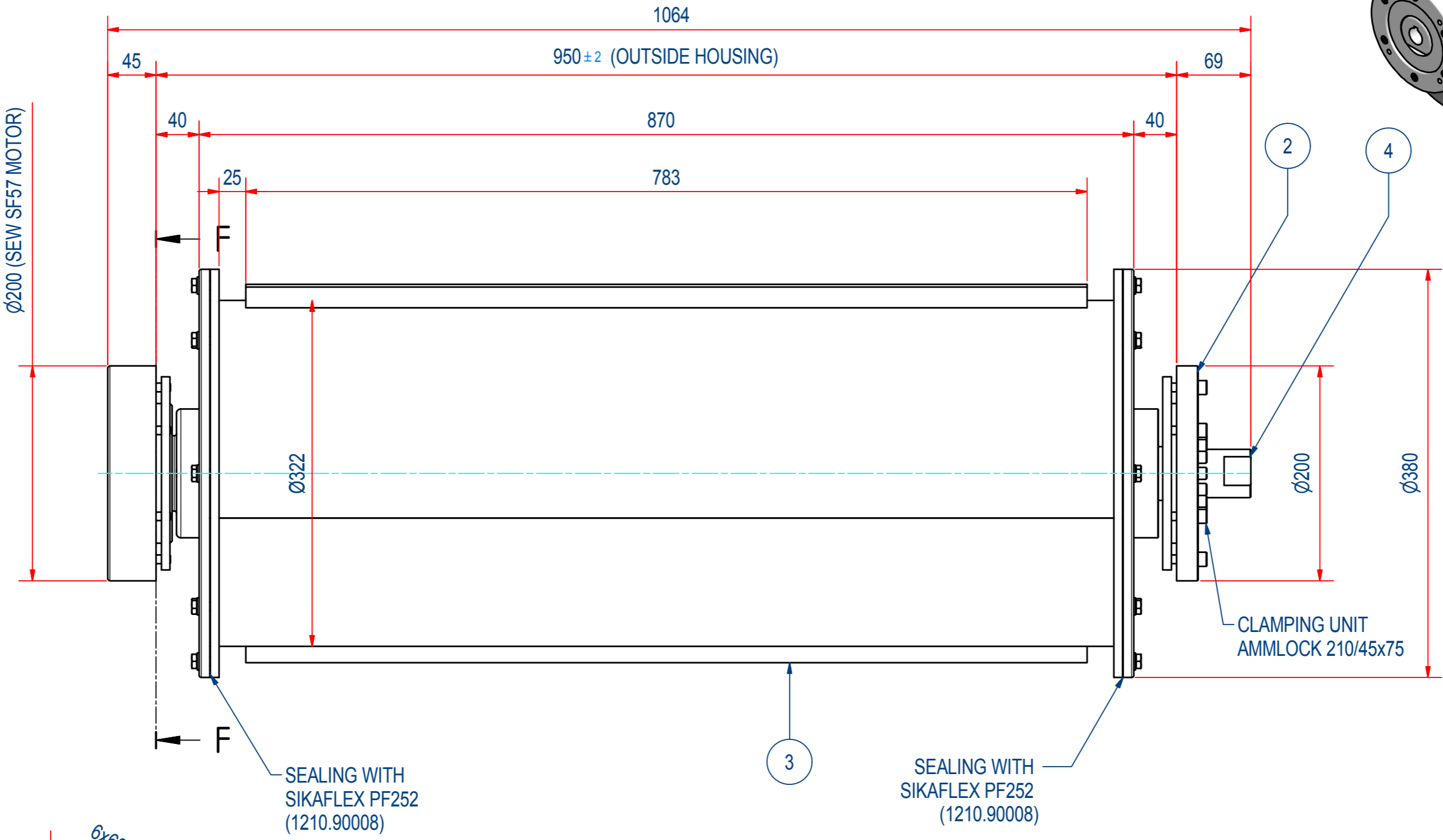
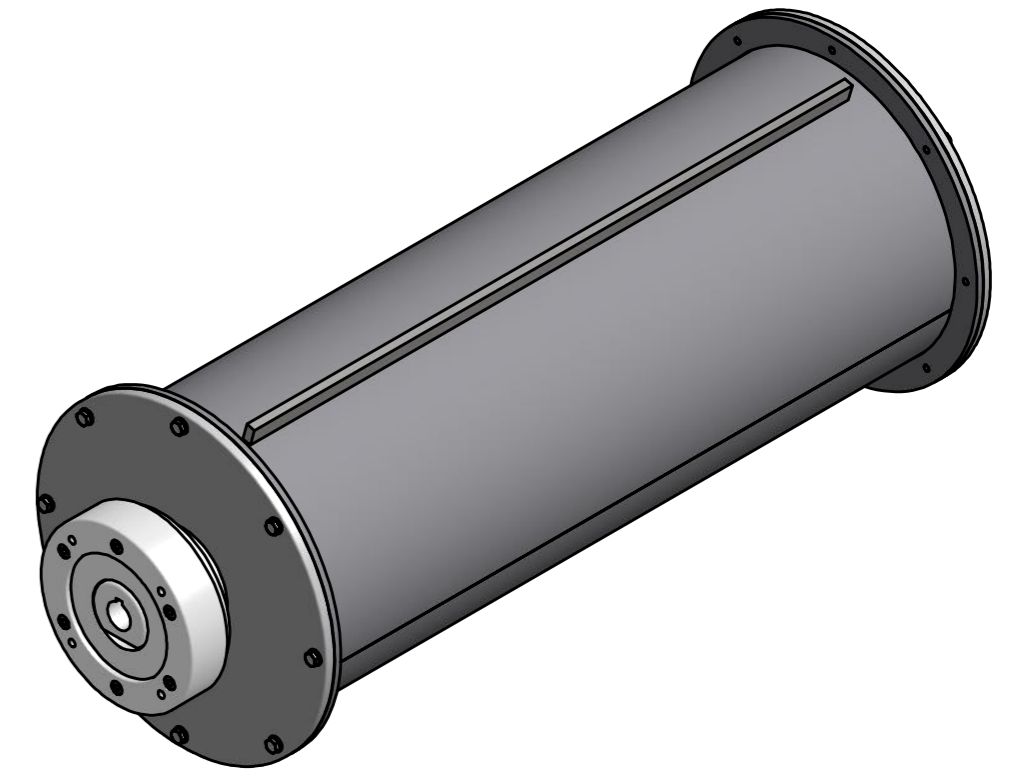
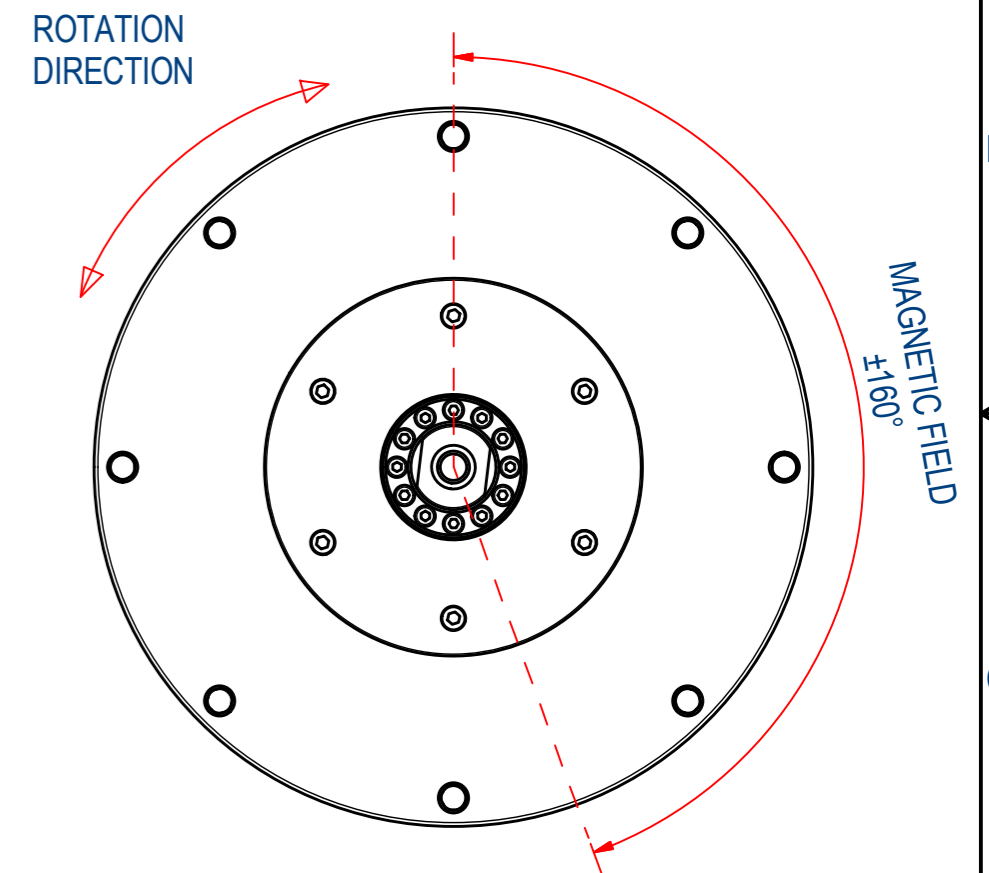

ITEM	QTY	PART NUMBER	DESCRIPTION	Dimensions
4	1	E0009976	DR-08 AXLE ST	
3	1	E0047686	SHELL WITH CLEATS RECD 08	
2	1	E0011058	DR-00 FLANGE ASSY ALU	
1	1	E0012935	DR-08-F DRUM ASSY (0.18 T)	

RAW MAT.	QTY	MAT. NUMBER	MAT. DESCRIPTION	LENGTH (mm)	WIDTH (mm)
Sheet:	A2	Extra info:	General tolerance:	ISO 2768 - cL	
Drawn:	TD	Weight (kg):	129.8	Drawn according:	
Date:	10-12-2014	Status:		Released	
Spare part:	False	Customer reference number:			
Quick search:	RMD-08	File number:		E0026049	Rev: A
Description:	RMD-08-32-RN-F-OR-30S2			Part number:	E0026048
				Rev:	A

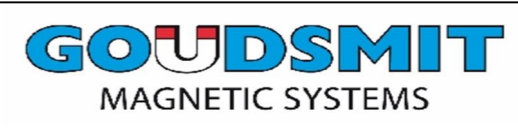

© All rights reserved. Reproduction is not permitted without written permission of GOUDSMIT Magnetic Systems BV