

REV	DATE	BY	DESCRIPTION
-	15-12-2014	TD	Reference drawing = E0025963
A	15-2-2016	GS	SHELL E0049022 WAS E00
B	19-10-2016	DD	DIMENSIONS AND VIEW AND PRODUCT KEY CHANGED

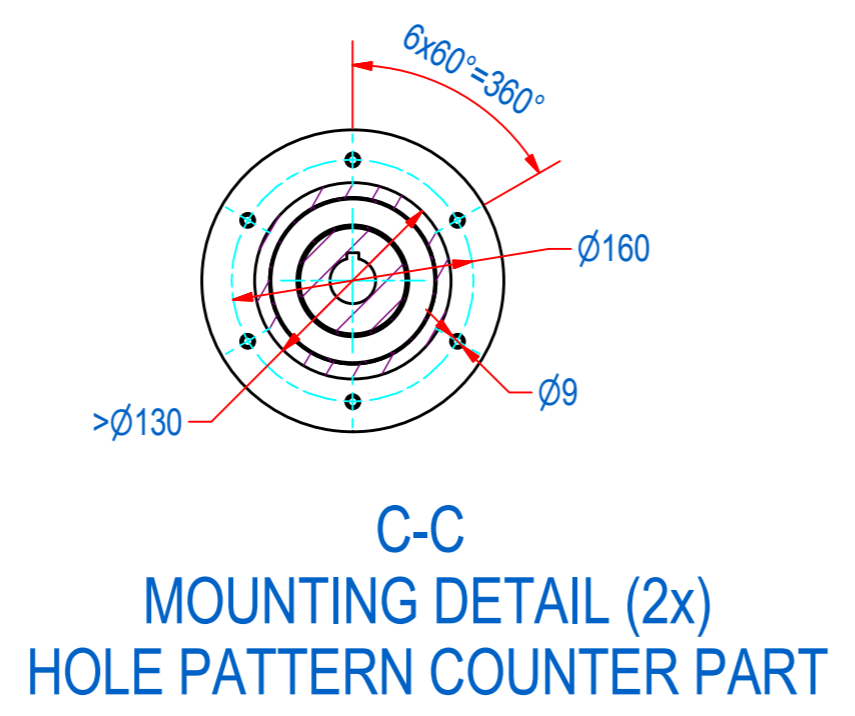
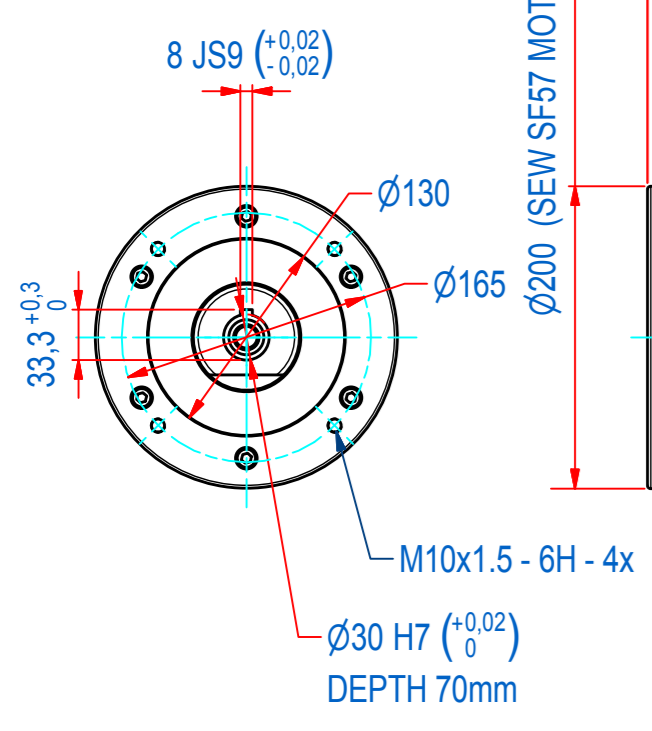
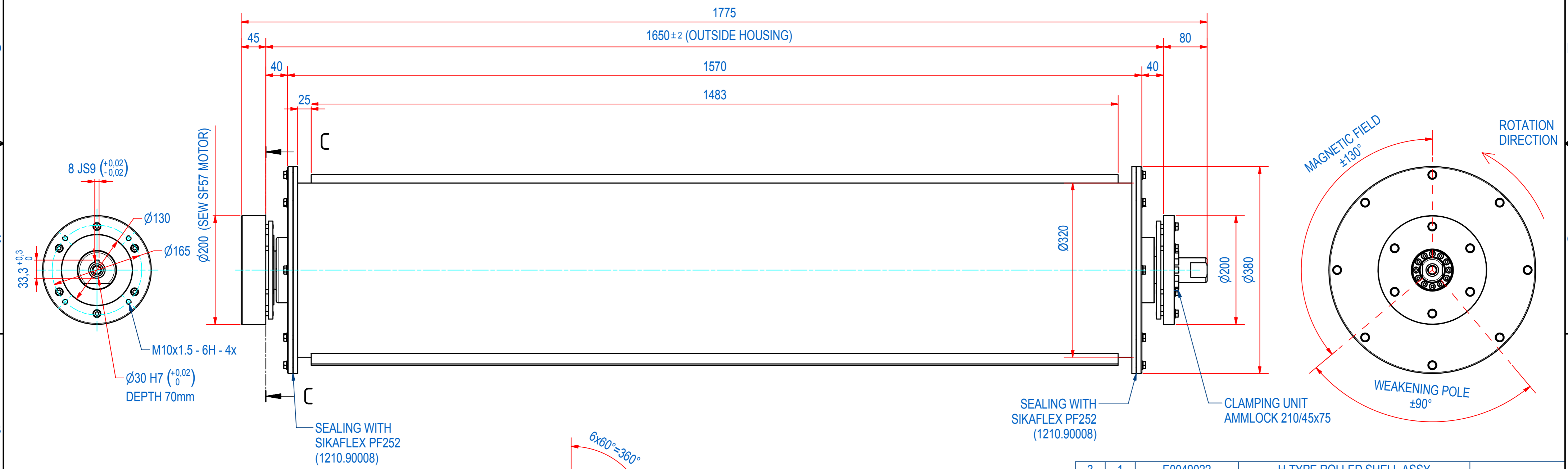
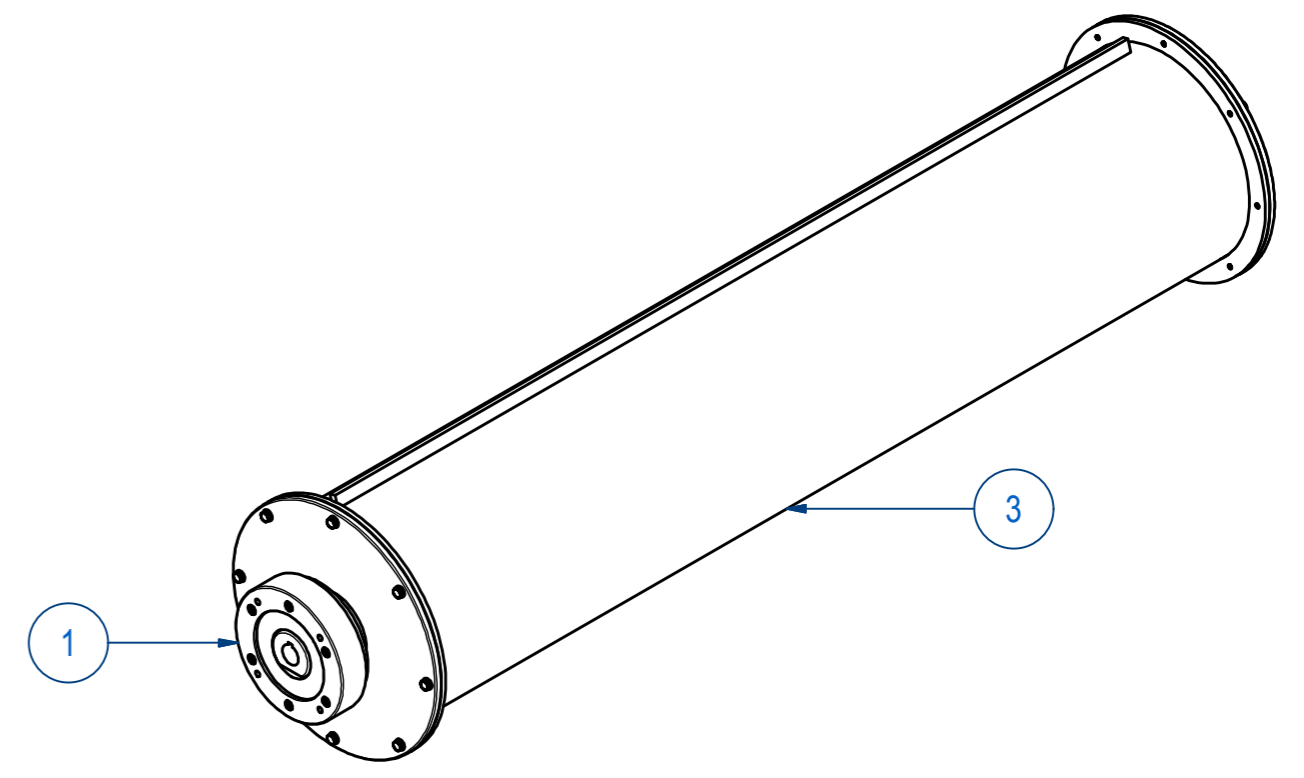

ITEM	QTY	PART NUMBER	DESCRIPTION	Dimensions
3	1	E0049022	H-TYPE ROLLED SHELL ASSY	
2	1	E0026155	H-TYPE MAGNET PACK	
1	1	E0011058	FLANGE ASSY	

RAW MAT.	Quantity	Material Number	Material Description	Length (mm)	Width (mm)
	1				

Sheet:	A2	Extra info:	General tolerance:	ISO 2768 - mK	
Drawn:	TD	Weight (kg):	401,5	Drawn according:	ISO268; ISO1101; ISO2553
Date:	15-12-2014			Status:	Released
Spare part:	False	Source:	MO-C	Customer reference number:	
Quick search:	RMD-15			Document number:	E0026237
Description:	RMD-15-32-RN-H-OR-20S2			Doc.Rev:	B
				Part number:	E0026236
				Rev:	B

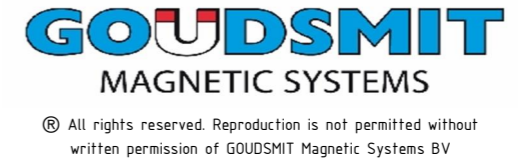

© All rights reserved. Reproduction is not permitted without written permission of GOUDSMIT Magnetic Systems BV