

REV	DATE	BY	DESCRIPTION
-	5-6-2015	CR	REFERENCE DRAWING E0011932
A	18-11-2016	CR	ITEM 2 CHANGED: E0019444 WAS E0012550

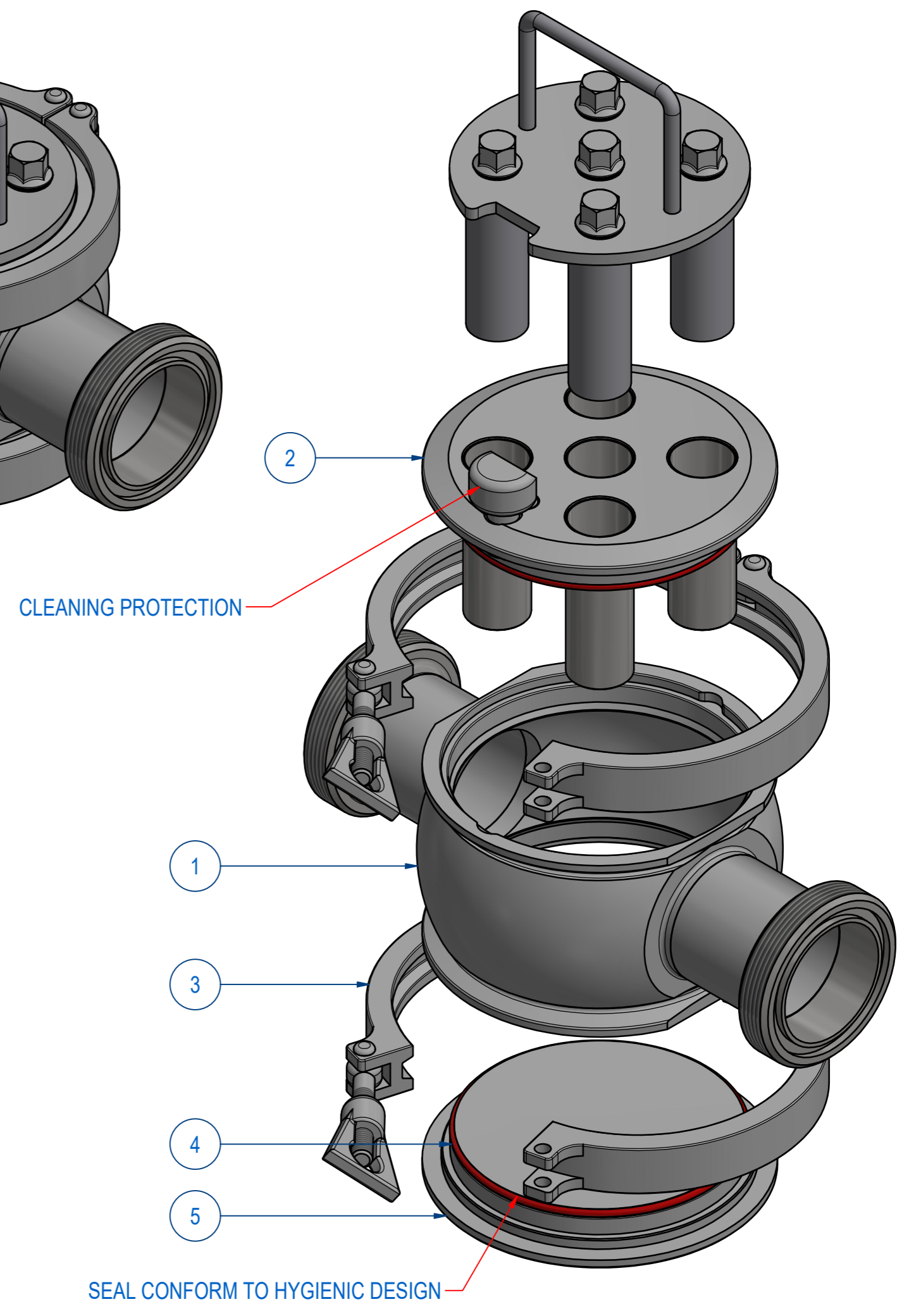
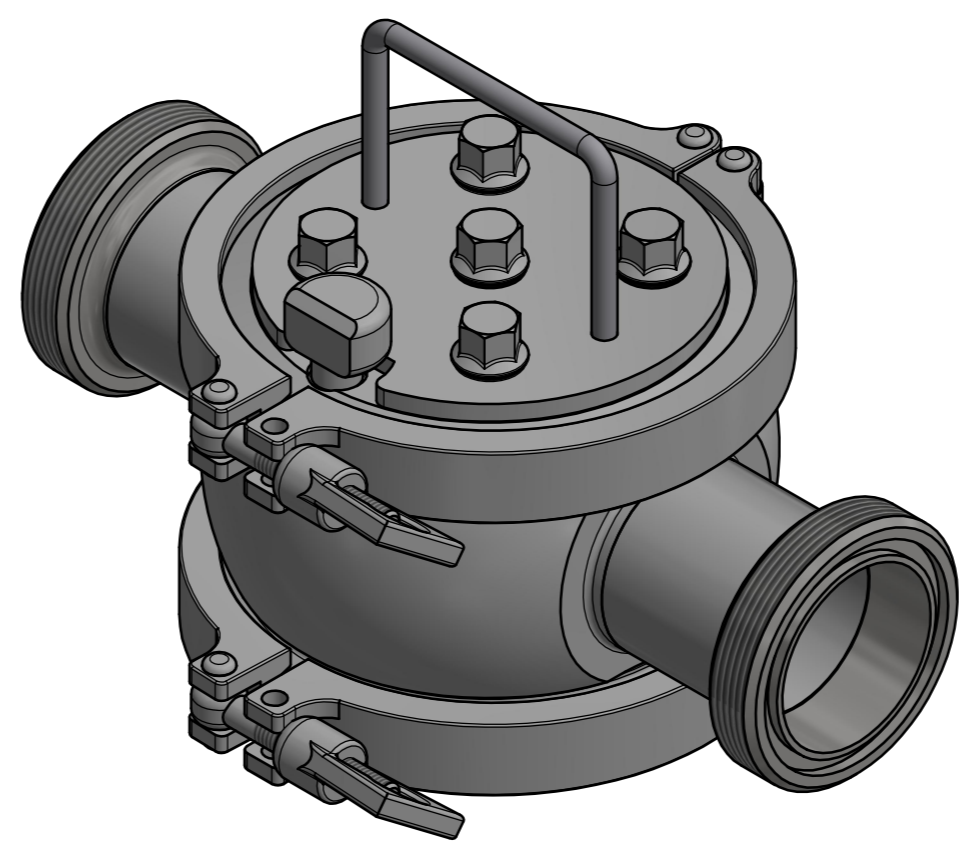
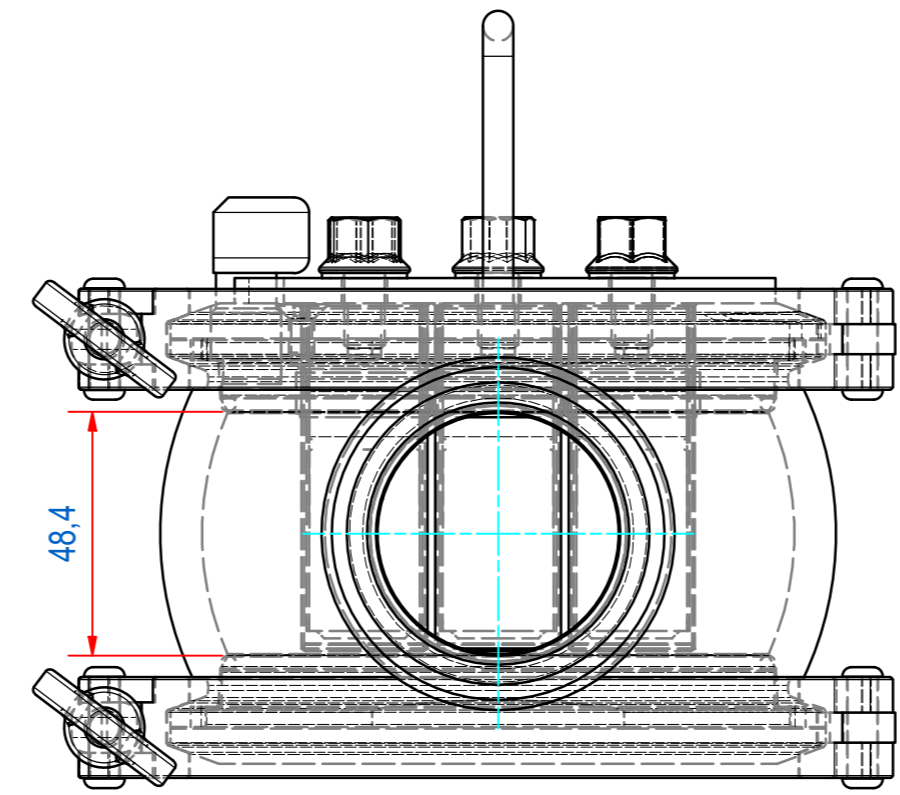
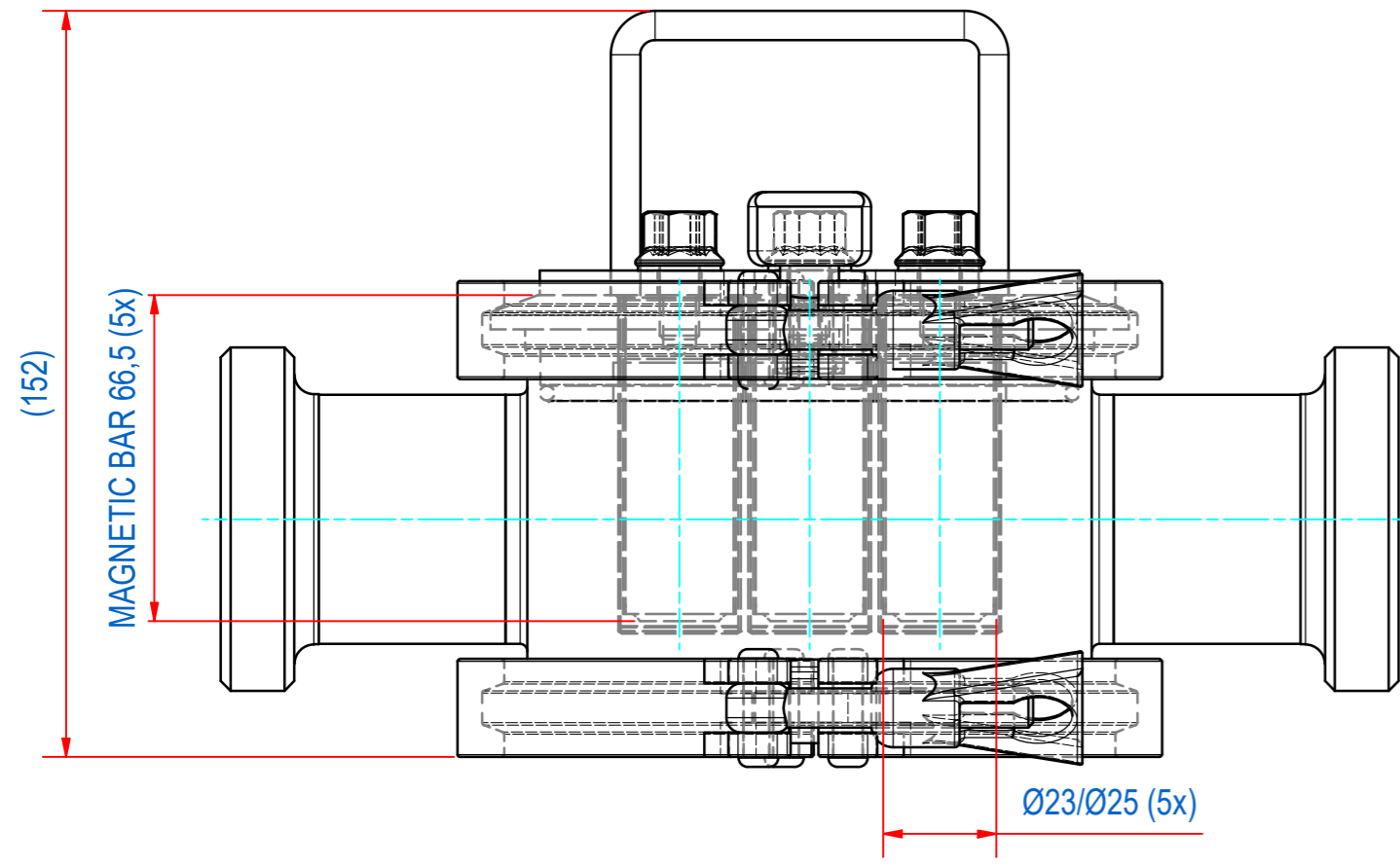
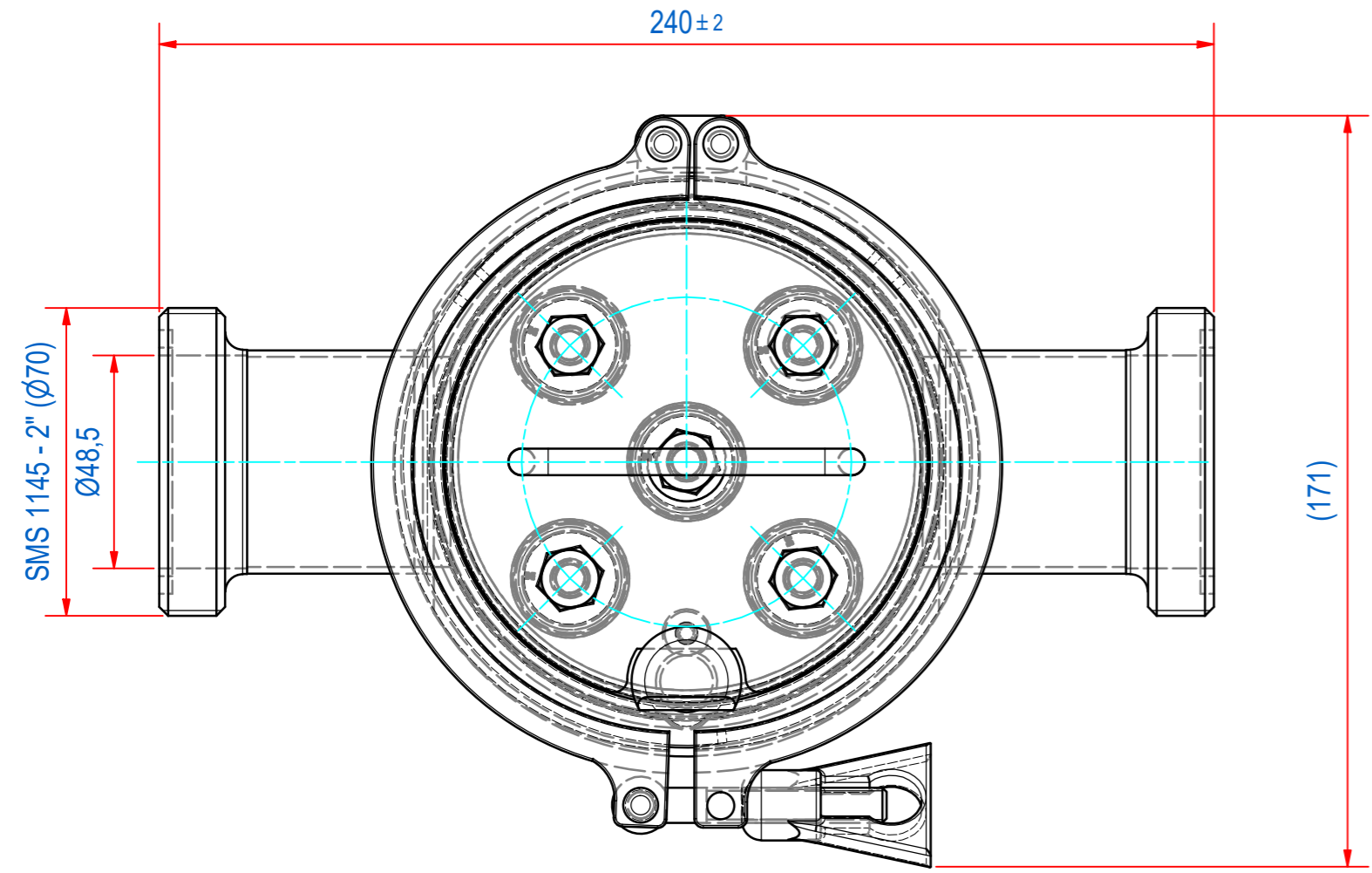

ITEM	QTY	PART NUMBER	DESCRIPTION	Dimensions
5	1	E0014904	SFH-50 BOTTOM PLATE 316L	
4	2	E0017388	O-RING Ø104x3 EC1935 SILIC. RED	
3	2	77.9630092	CLAMP LIGHT ISO-2852 4.5"	
2	1	E0019444	SFH-SPARE-2"-05E-HT FILTER TOP	
1	1	E0016254	SFH-2" SMS 1145 HOUSE 316L	

RAW MAT.	Quantity	Material Number	Material Description	Length (mm)	Width (mm)
⊕	1				

Sheet: A2	Extra info: MAGNETIC FILTER	General tolerance: ISO 2768 - mK
Drawn: AVD	Weight (kg): 8,2	Drawn according: ISO268; ISO1101; ISO2553
Date: 13-5-2015		Status: Standard
Spare part: False	Source:	Customer reference number:
Quick search: SFH-2"		
Description: SFH-2"-ST-05E-HT-F5M-S-B-B-B	Document number: E0033997	Doc.Rev: A
	Part number: E0033996	Rev: A