

REV	DATE	BY	DESCRIPTION
B	9-2-2017	TD	DESCRIPTION CHANGED
C	5-2-2018	PB	NOTHING CHANGED
D	6-4-2018	PV	PRODUCT STICKER E0093307 ADDED

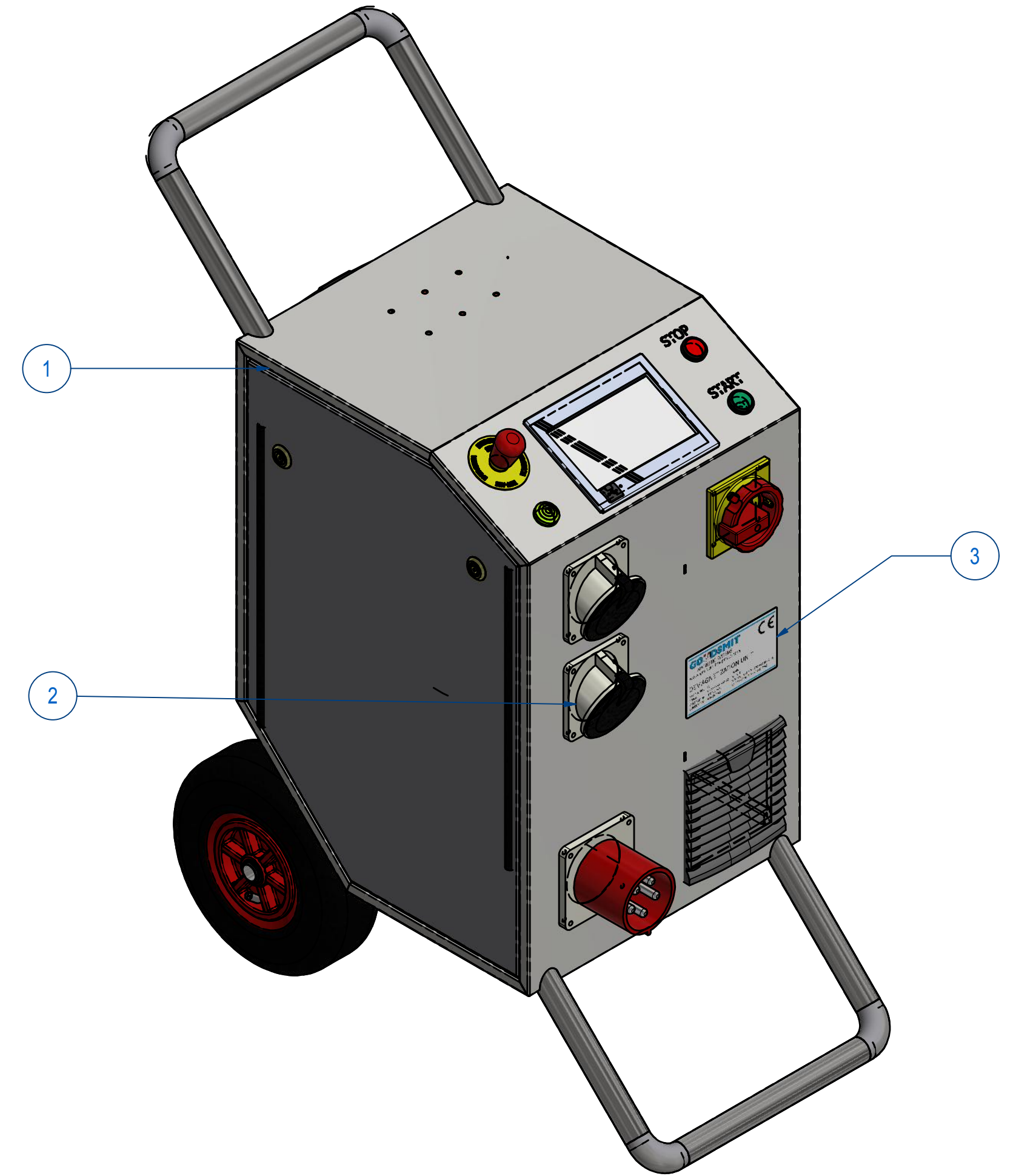
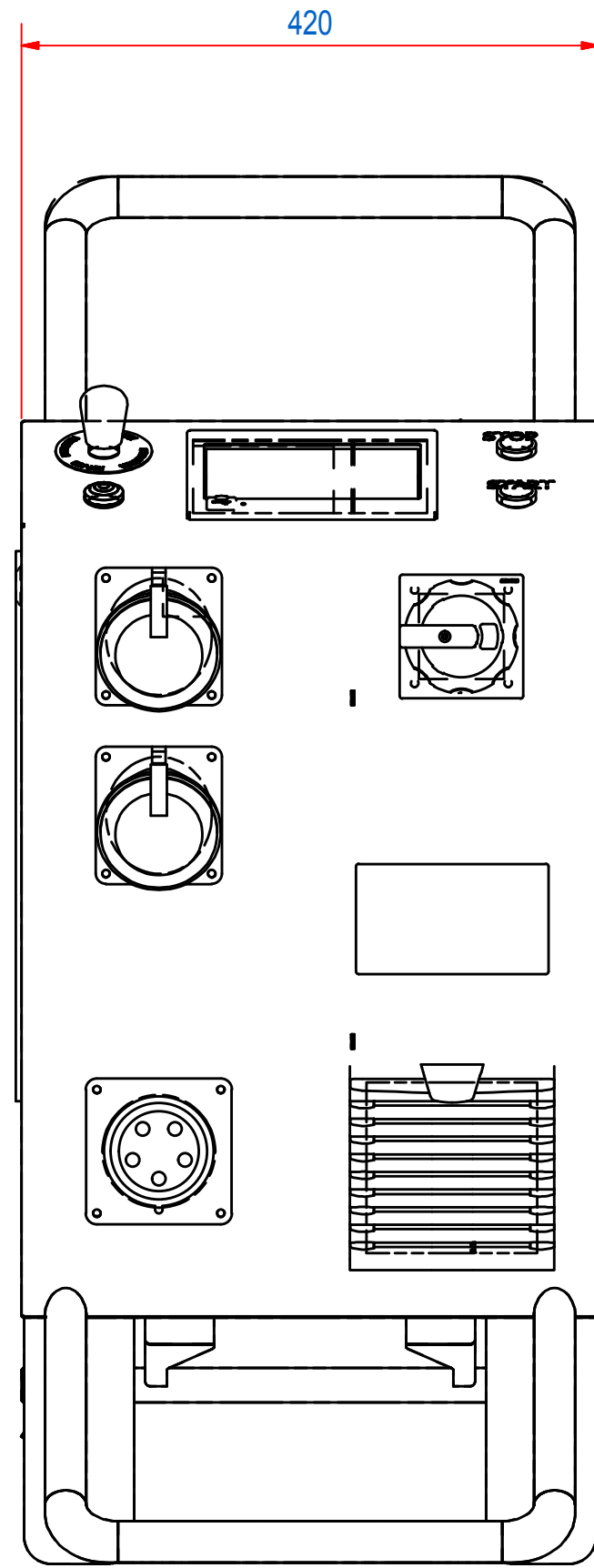
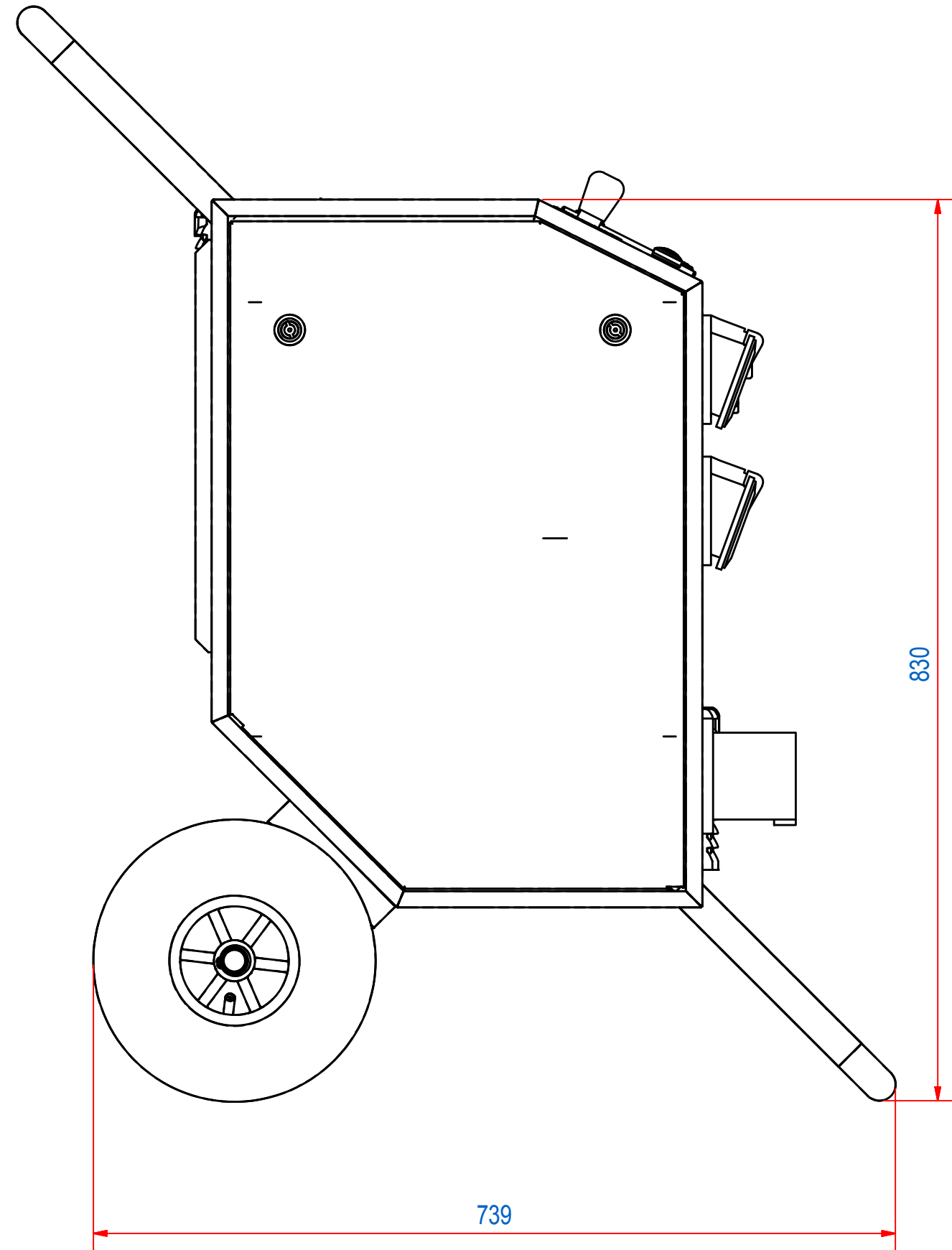

ITEM	QTY	PART NUMBER	DESCRIPTION	Dimensions
3	1	E0093307	STICKER DEMAGNETIZATION UNIT	
2	1	E0059772	DEMAG ELECTRO PARTS	
1	1	E0059766	DEMAG TROLLEY WELDING	

RAW MAT.	QTY	MAT. NUMBER	MAT. DESCRIPTION	LENGTH (mm)	WIDTH (mm)
	1				

Sheet: <b>A2</b>	Extra info:	General tolerance: <b>ISO 2768- mK</b>
Drawn: <b>TD</b>	Weight (kg): <b>50</b>	Drawn according: <b>ISO268; ISO1101; ISO2553</b>
Date: <b>5-9-2016</b>		Status: <b>Released</b>
Spare part: <b>False</b>		Customer reference number:
Quick search: <b>DEMAG</b>		Document number: <b>E0059751</b>
Description: <b>DEMAG TROLLEY</b>		Doc.Rev: <b>D</b>
		Part number: <b>E0059750</b>
		Rev: <b>D</b>