

| REV | DATE | BY | DESCRIPTION |
|-----|------------|----|-------------------------------------|
| - | 10-10-2017 | CR | REFERENCE DRAWING SEVN010660 |
| A | 2-4-2019 | CR | PTFE TAPE ADDED |
| B | 29-7-2022 | CR | COMPLETELY AISI316L AND BOM CHANGED |

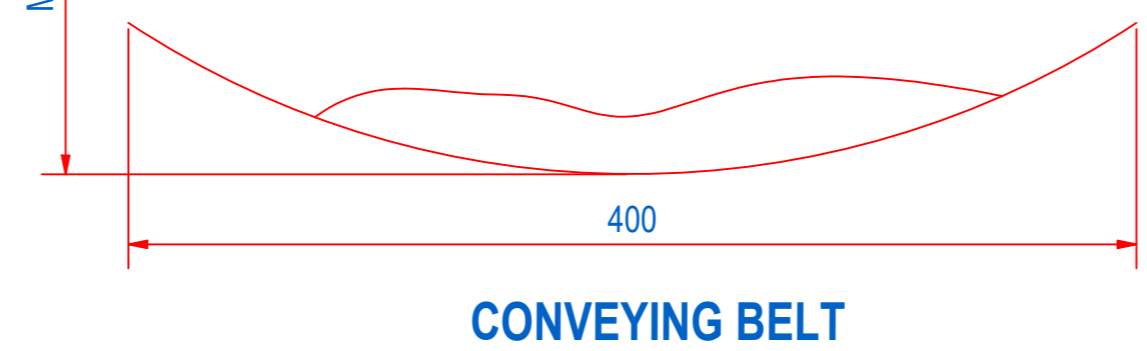
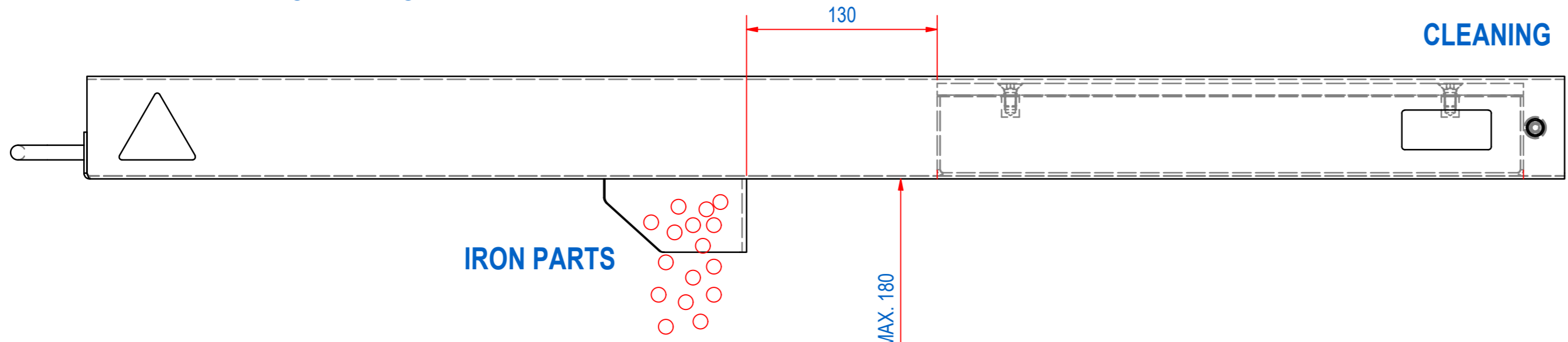
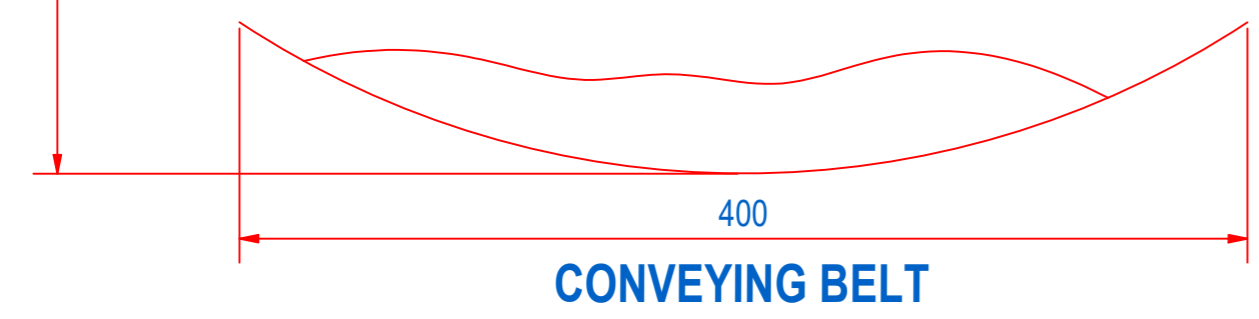
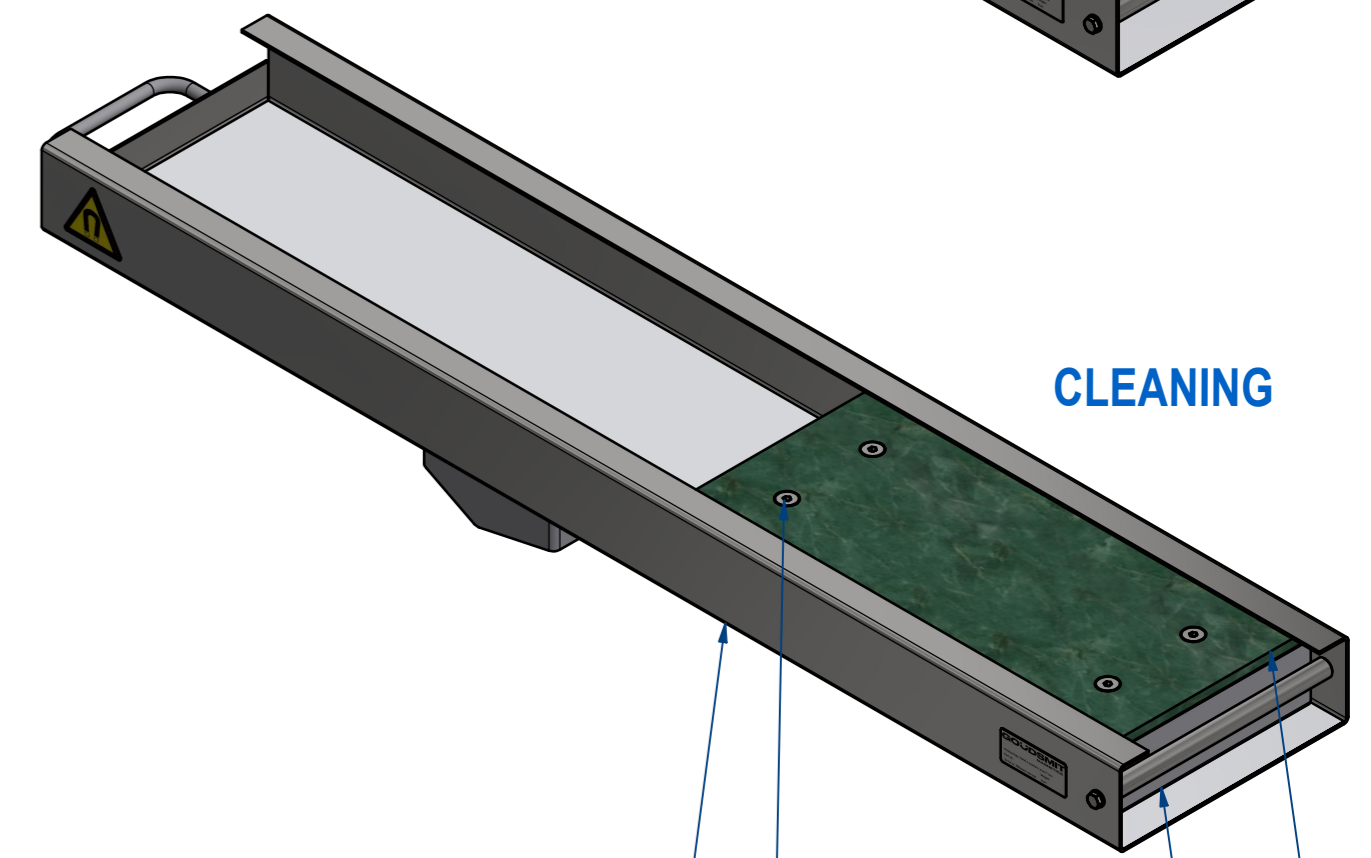
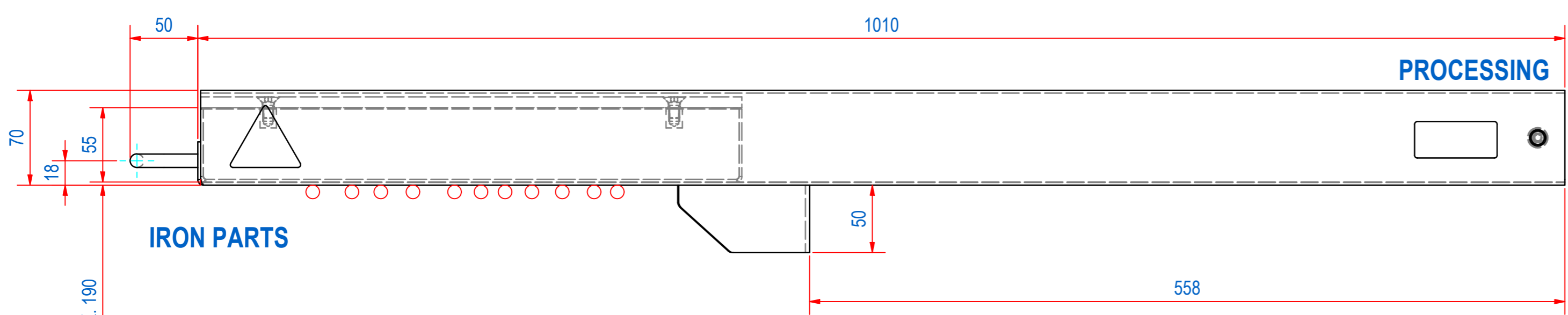
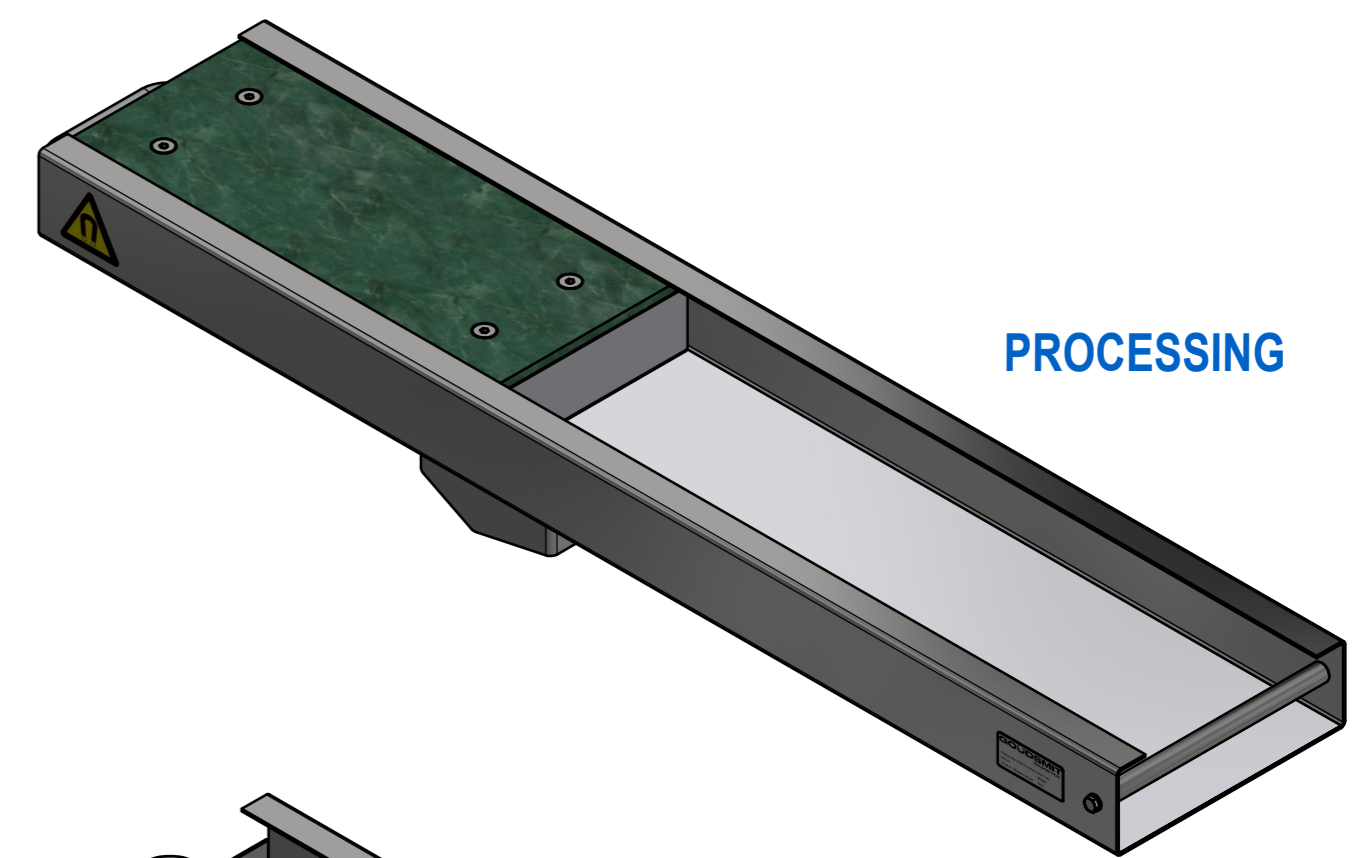
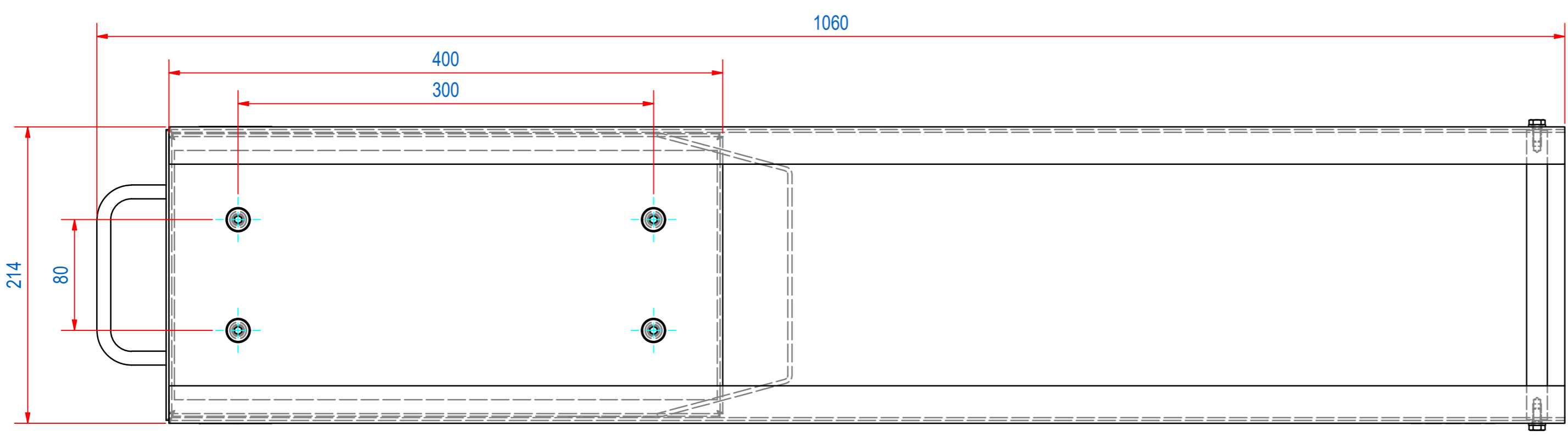

| ITEM | QTY | PART NUMBER | DESCRIPTION | Dimensions |
|------|-----|-------------|------------------------------|------------|
| 4 | 4 | 52.0308016 | SCREW, HEX S CS M8x16 - A4 | M8x16 |
| 3 | 1 | SVMN020400 | SVM-N-204x55-0400-B-F1M | |
| 2 | 1 | E0083034 | SVM-400 GUIDANCE STRIP L=400 | |
| 1 | 1 | E0153445 | SVM-400 EXTRACTOR TRAY ASSY | |

| RAW MAT. | Quantity | Material Number | Material Description | Length (mm) | Width (mm) |
|----------|----------|-----------------|----------------------|-------------|------------|
| 1 | 1 | | | | |

| | | |
|---|---|--|
| Sheet: A2 Drawn: CR Date: 5-7-2019 Spare part: False Quick search: VMN92-400 | Extra info: Weight (kg): 34 Source: GOUDSMIT MAGNETICS <small>© All rights reserved. Reproduction is not permitted without written permission of GOUDSMIT Magnetic Systems BV</small> | General tolerance: ISO 2768 - mK Drawn according: ISO268; ISO1101; ISO2553 Status: Released Customer reference number: Document number: E0083039 Doc.Rev: B Part number: E0083039 Rev: B |
|---|---|--|