

REV	DATE	BY	DESCRIPTION
-	2-4-2019	CR	REFERENCE DRAWING SEVN010660
A	29-7-2022	CR	COMPLETELY AISI316L AND BOM CHANGED

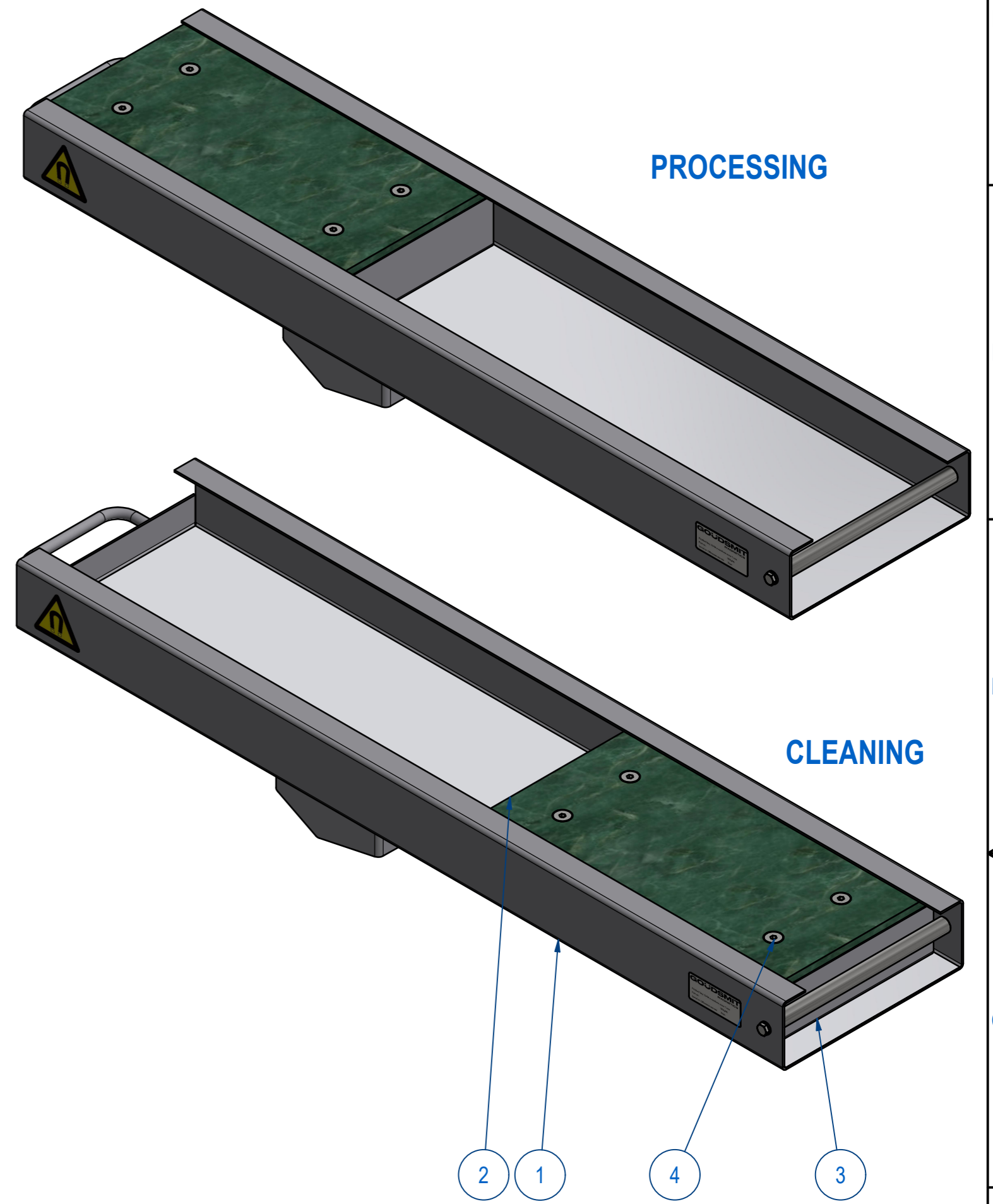

ITEM	QTY	PART NUMBER	DESCRIPTION	Dimensions	
4	4	52.0308016	SCREW, HEX S CS M8x16 - A4	M8x16	
3	1	SVMN020350	SVM-N-204x55-0350-B-F1M		
2	1	E0083318	SVM-350 GUIDANCE STRIP L=350		
1	1	E0153440	SVM-350 EXTRACTOR TRAY ASSY		
RAW MAT.	Quantity	Material Number	Material Description	Length (mm)	Width (mm)
	1				
Sheet: A2		Extra info:		General tolerance: ISO 2768 - mK	
Drawn: CR		Weight (kg): 30		Drawn according: ISO268; ISO1101; ISO2553	
Date: 5-7-2019				Status: Released	
Spare part: False		Source:		Customer reference number:	
Quick search:		Description:		Document number: E0083320 Doc.Rev: A	
		SVM-N-204x55-0350-T-F1M		Part number: E0083320 Rev: A	

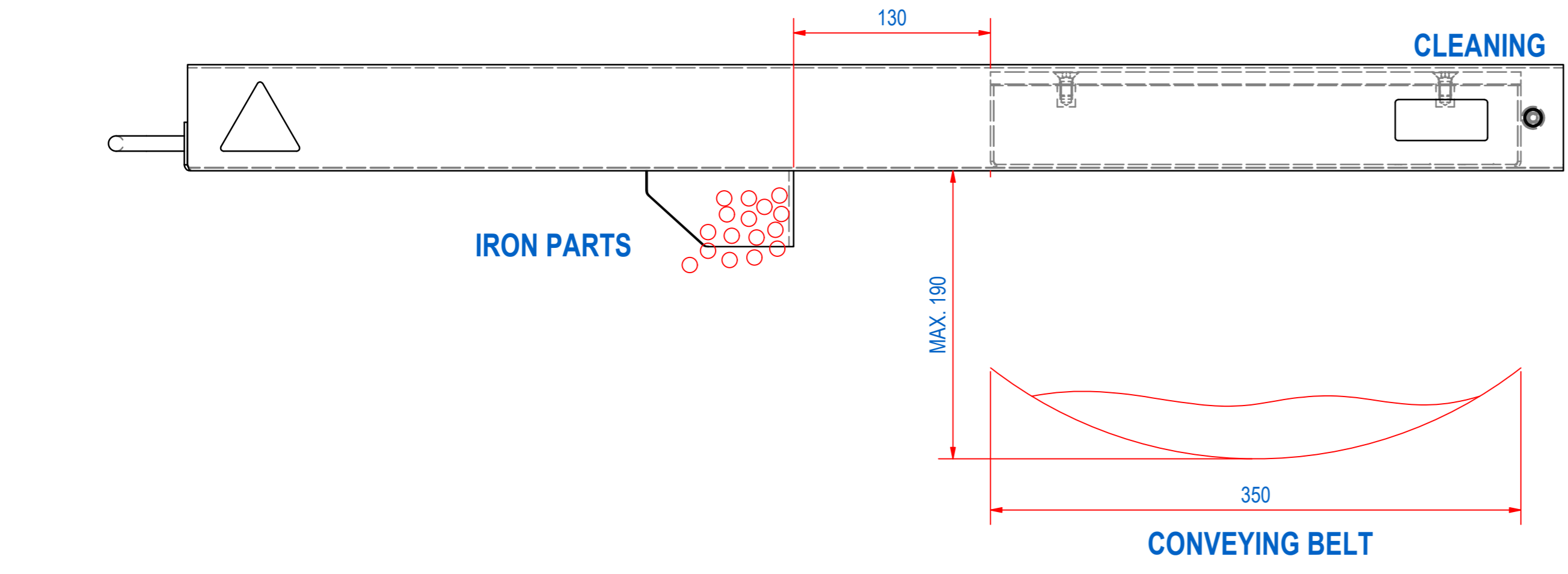
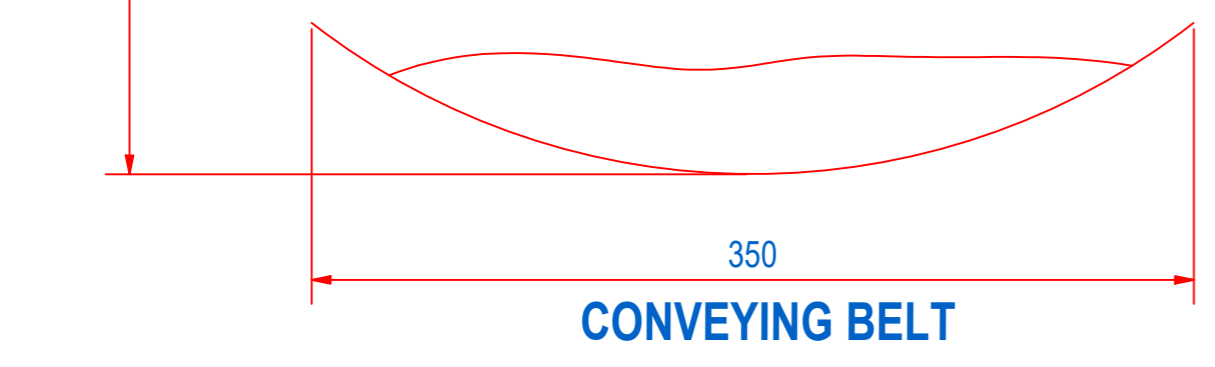
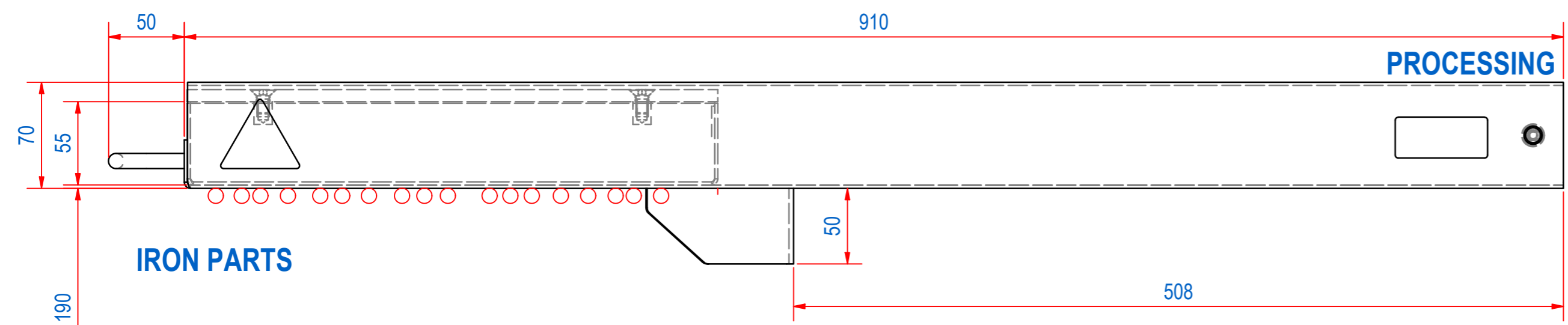
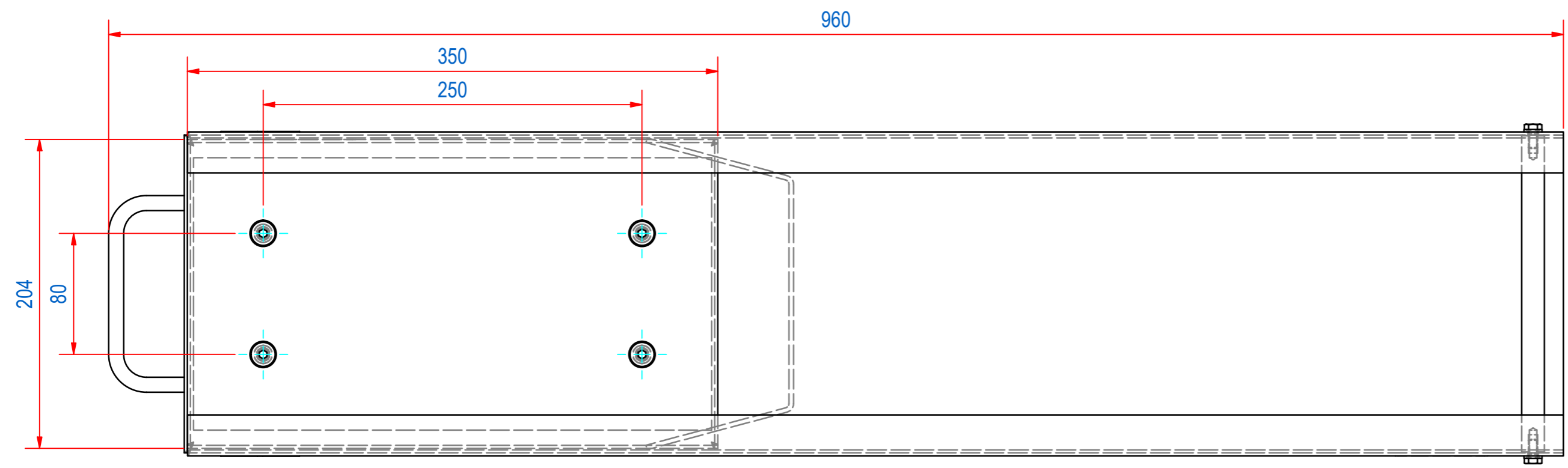

© All rights reserved. Reproduction is not permitted without written permission of GOUDSMIT Magnetic Systems BV