

PLACE STICKER AT SENSOR (4x)
PLAATS STICKER BIJ SENSOR (4x)

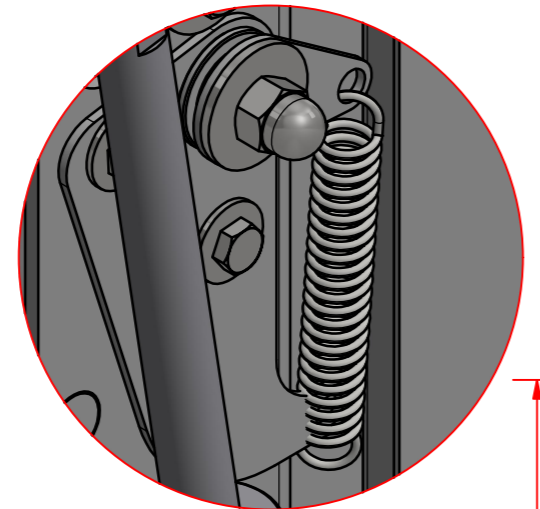

DEFLECTOR
M8x1.25 - 6H (20x) (2x)

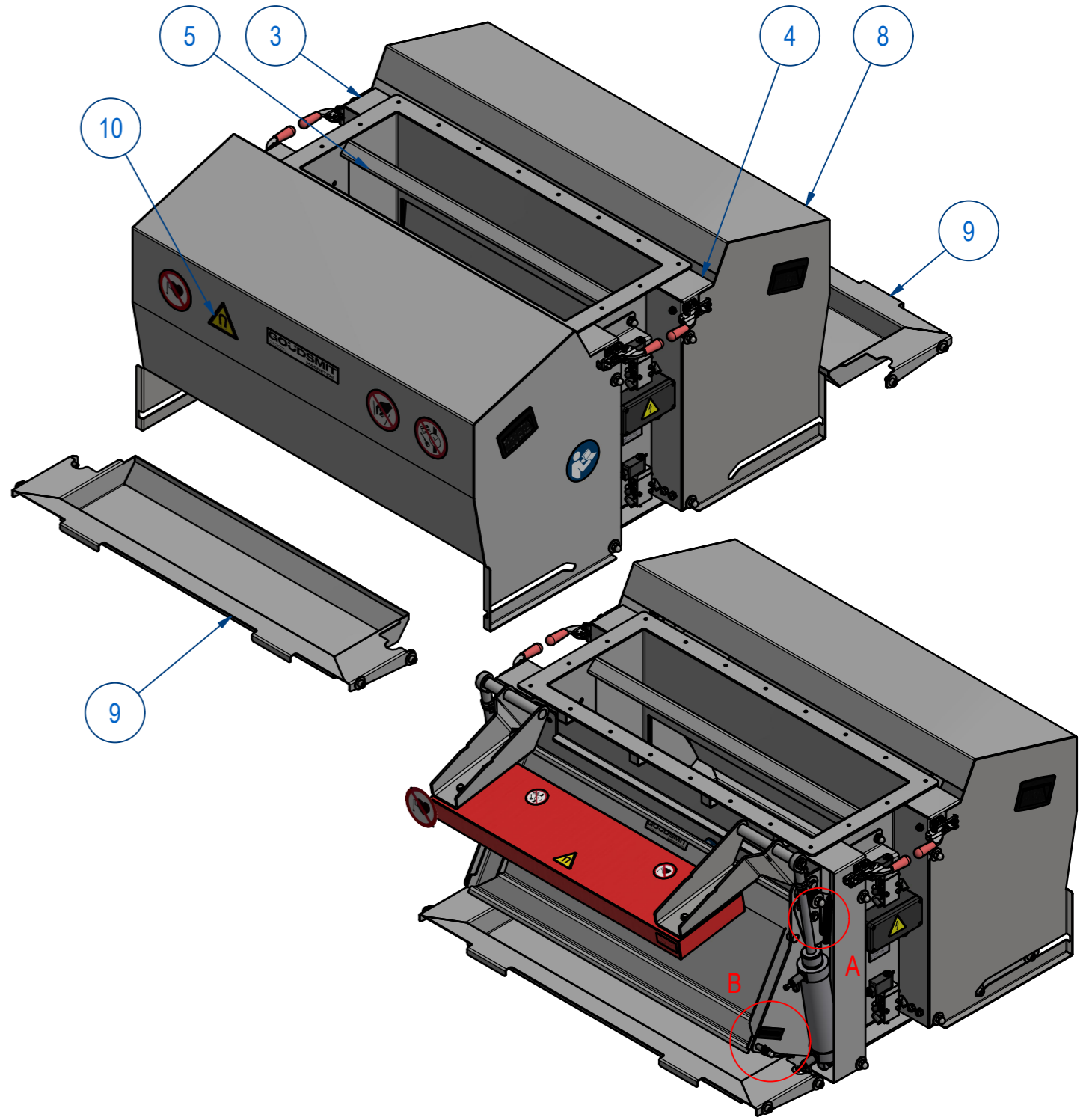
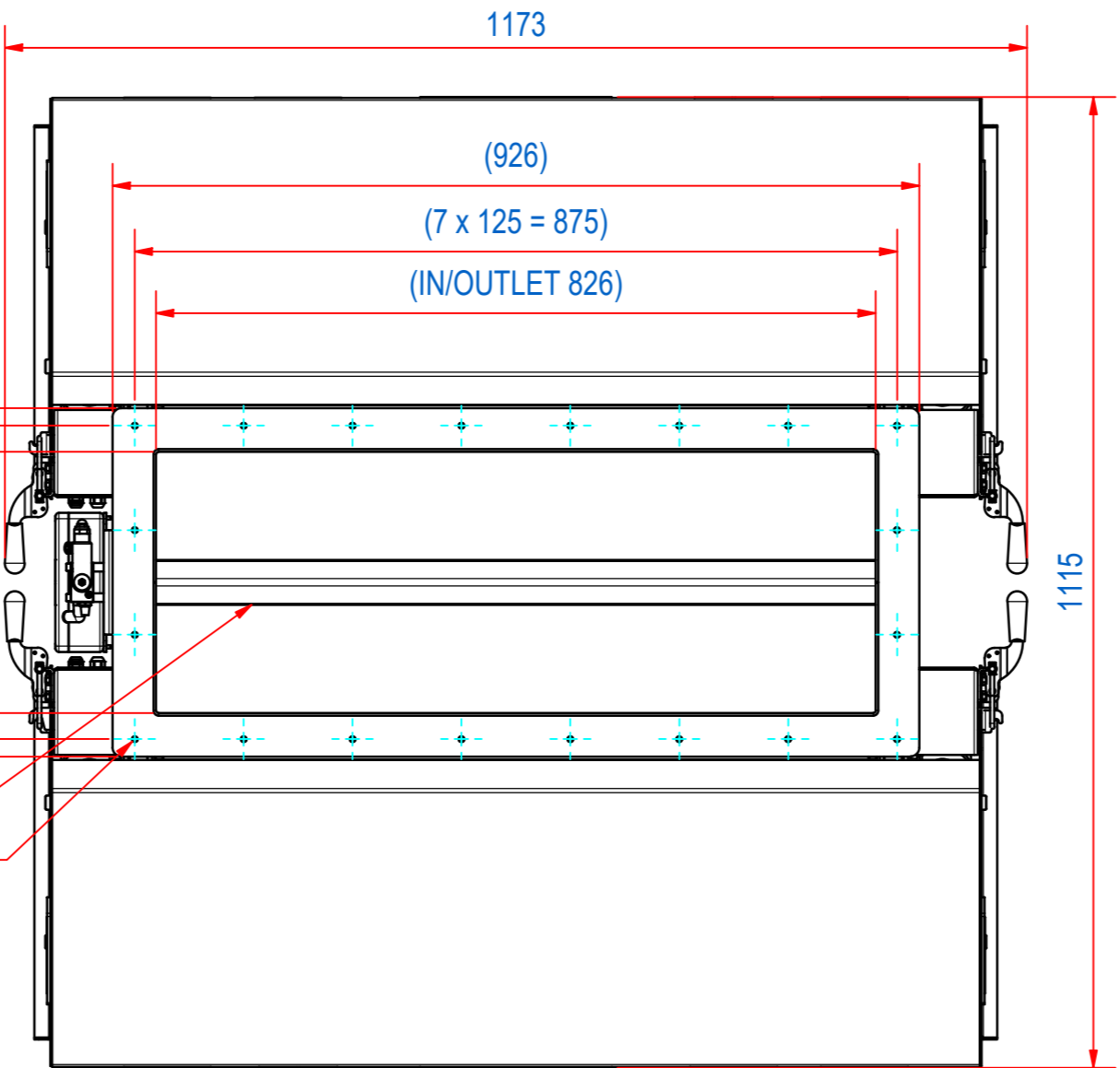

DOC.NR.	REV	DATE	BY	DESCRIPTION
E0119879	A	24-8-2022	CR	BOM CHANGED
E0119879	B	21-10-2022	CR	THREAD HOLES CHANGED: 20x M8 WAS 16x M8
E0119879	C	24-11-2023	CR	MC-C SOURCE CODE AND WARNING STICKERS ADDED

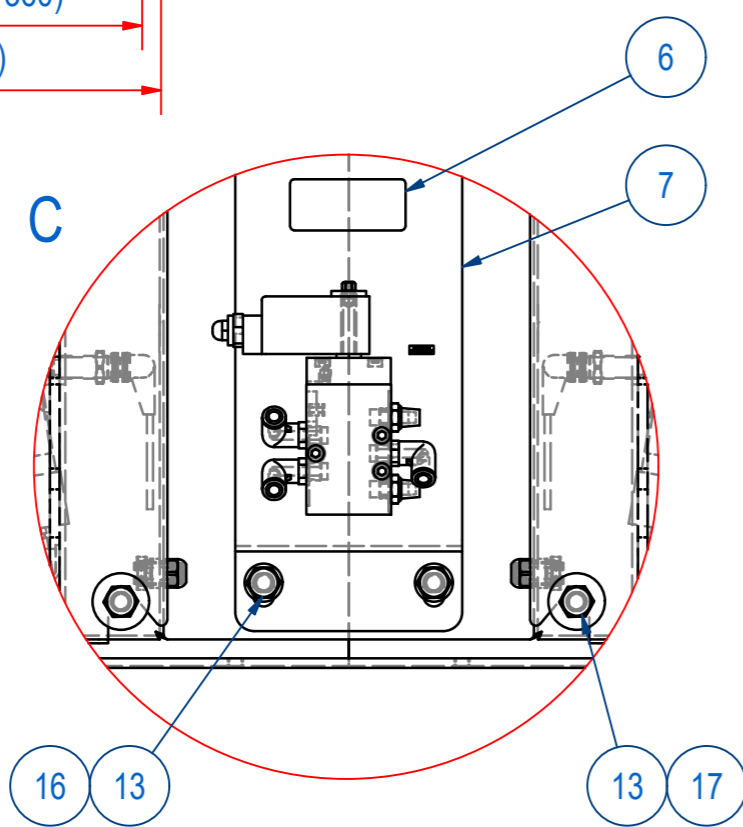
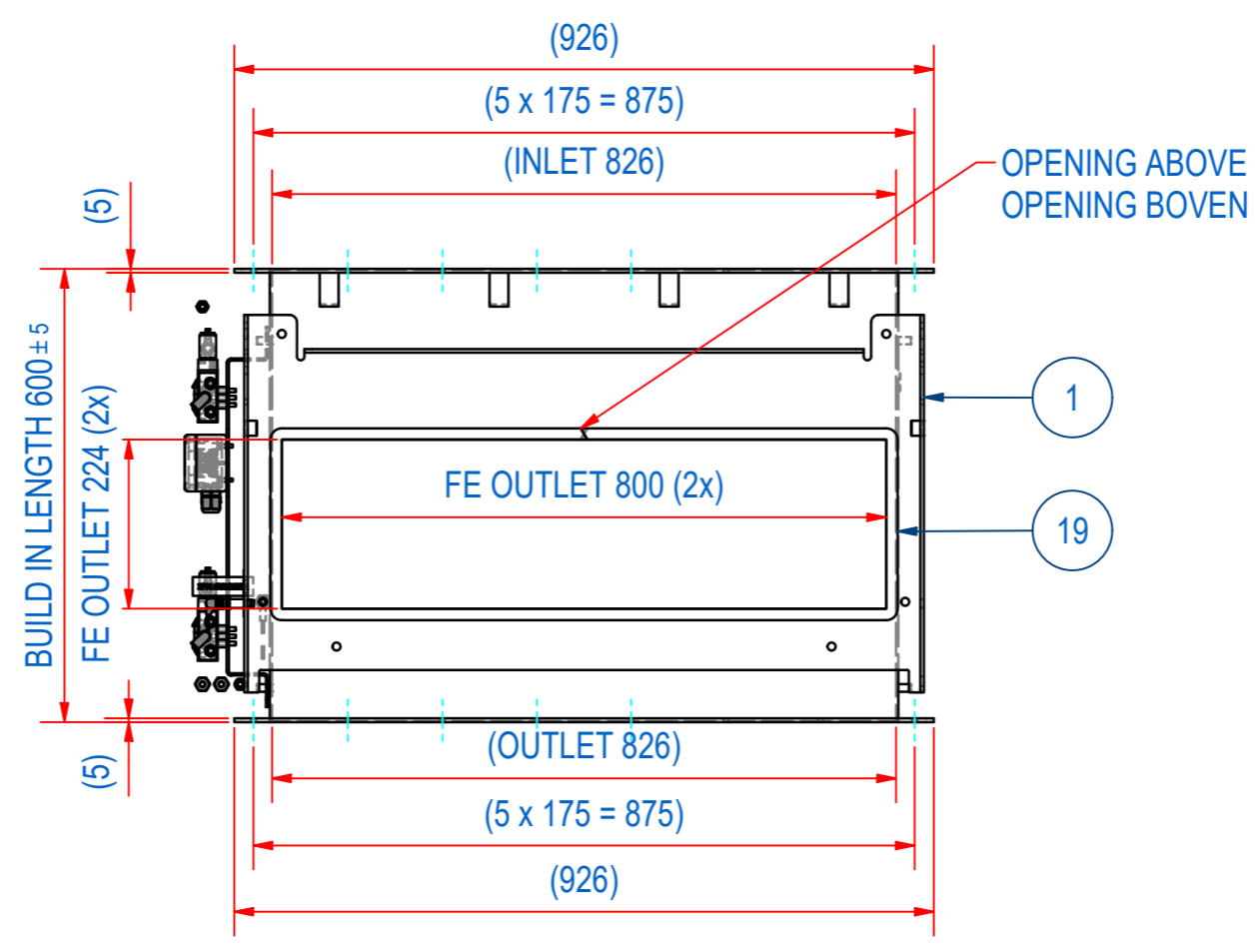
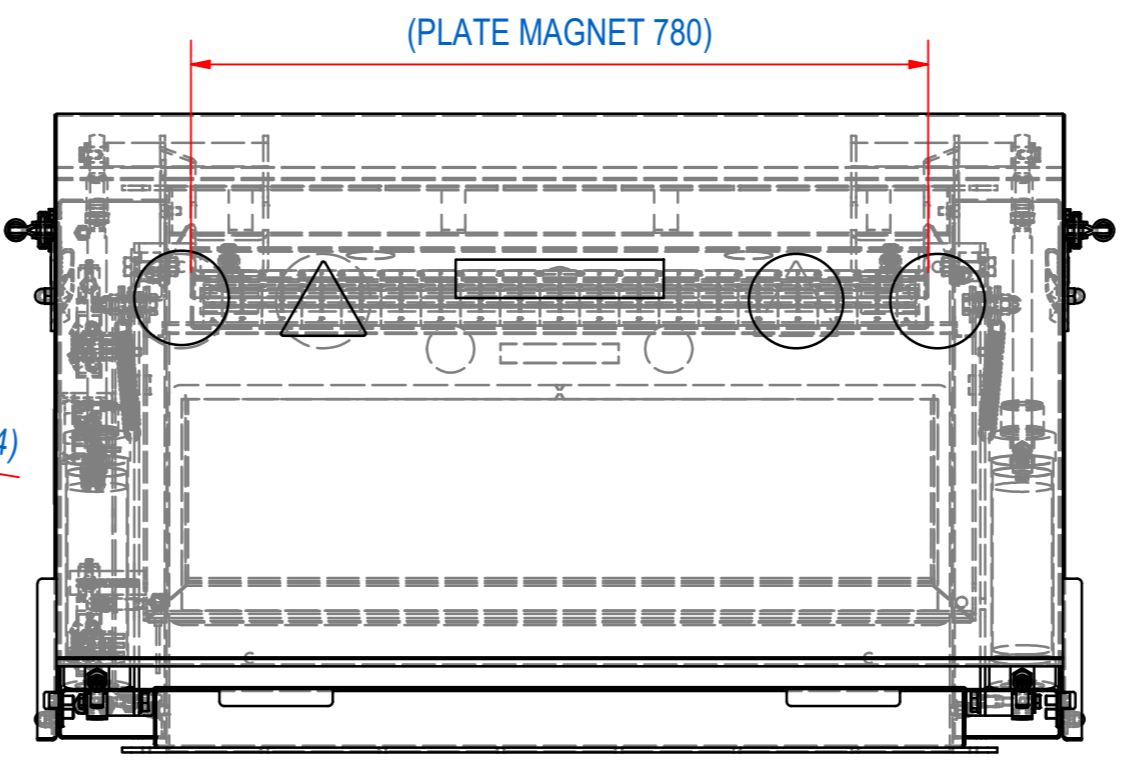
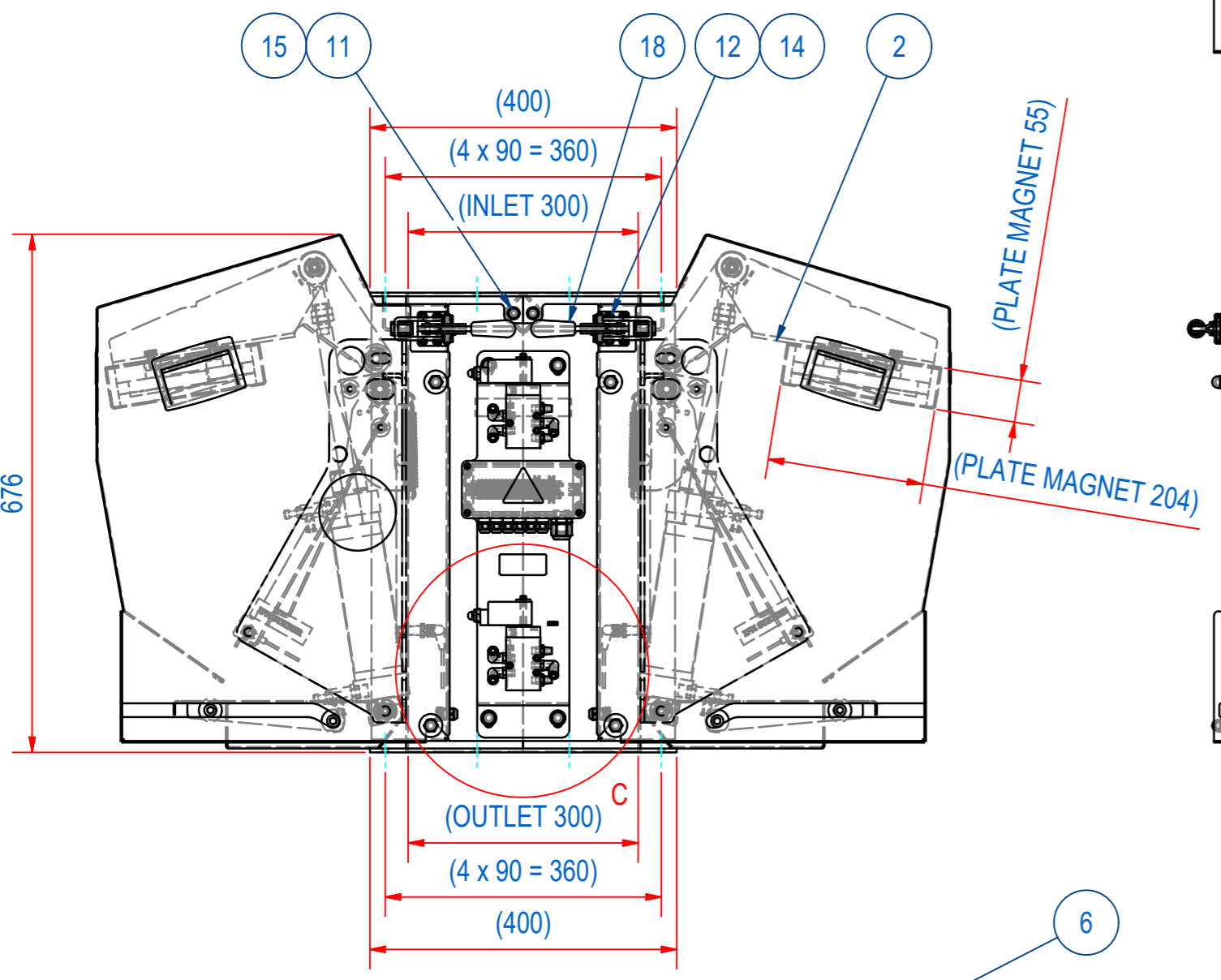

19	2	E0135873	SBPA-S-GASKET FOR VMN22-800 WHITE	
18	4	1003.10006	QUICK ACTING CLAMP 331-SS	
17	8	70.8300010	WASHER 3xd M10x30 - A4	M10x30
16	8	70.0300010	WASHER M10 - A4	M10
15	4	70.0300008	WASHER M8 - A4	M8
14	16	70.0300006	WASHER M6 - A4	M6
13	16	60.3300010	NUT, HEX CAP M10 - A4	M10
12	16	60.0300006	NUT, HEX M6 - A4	M6
11	4	50.1308016	BOLT, HEX M8x16-A4	M8 x 16
10	1	E0149152	SBPA-000 WARNING STICKERS	
9	2	E0150130	SBPA-0800 COLLECTOR TRAY	
8	2	E0150148	SBPA-0800 COVER	
7	1	E0149151	SBPA-000 CONTROL UNIT EX I13GD	
6	1	E0154524	SBPA-TYPE PLATE Ex 1/3D	
5	1	E0120109	SBPA-S-DEFLECTOR 40x40 CHUTE L826	
4	1	E0119946	SBPA-SUPPORT PLATE CHUTE WELD ASSY	
3	1	E0119970	SBPA-ASSY SUPPORT PLATE CHUTE	
2	2	E0119881	SCHZ-P-N-204x55-0800-B-B-B	
1	1	E0119883	SBPA-HOUSE CHUTE 800	

ITEM	QTY	PART NUMBER	DESCRIPTION	Dimensions
RAW MAT.	1			
Quantity		Material Number	Material Description	Length (mm) Width (mm)
Sheet:	A2	Extra info:	CHUTE MAGNET	General tolerance: ISO 2768 - mK
Drawn: RO	Weight (kg): 305	D63 CILINDERS		Drawn according: ISO286; ISO1101; ISO2553
Date: 1-8-2019				Status: Standard
Spare part: False	Source:			Customer reference number:
Quick search:				Document number: E0119879 Doc.Rev: C
Description: SBPA-8330-N-F1E-B-D3				Part number: E0119879 Rev: C