

DOC.NR.	REV	DATE	BY	DESCRIPTION
E0136511	-	26-1-2021	TT	ORIGINAL DRAWING

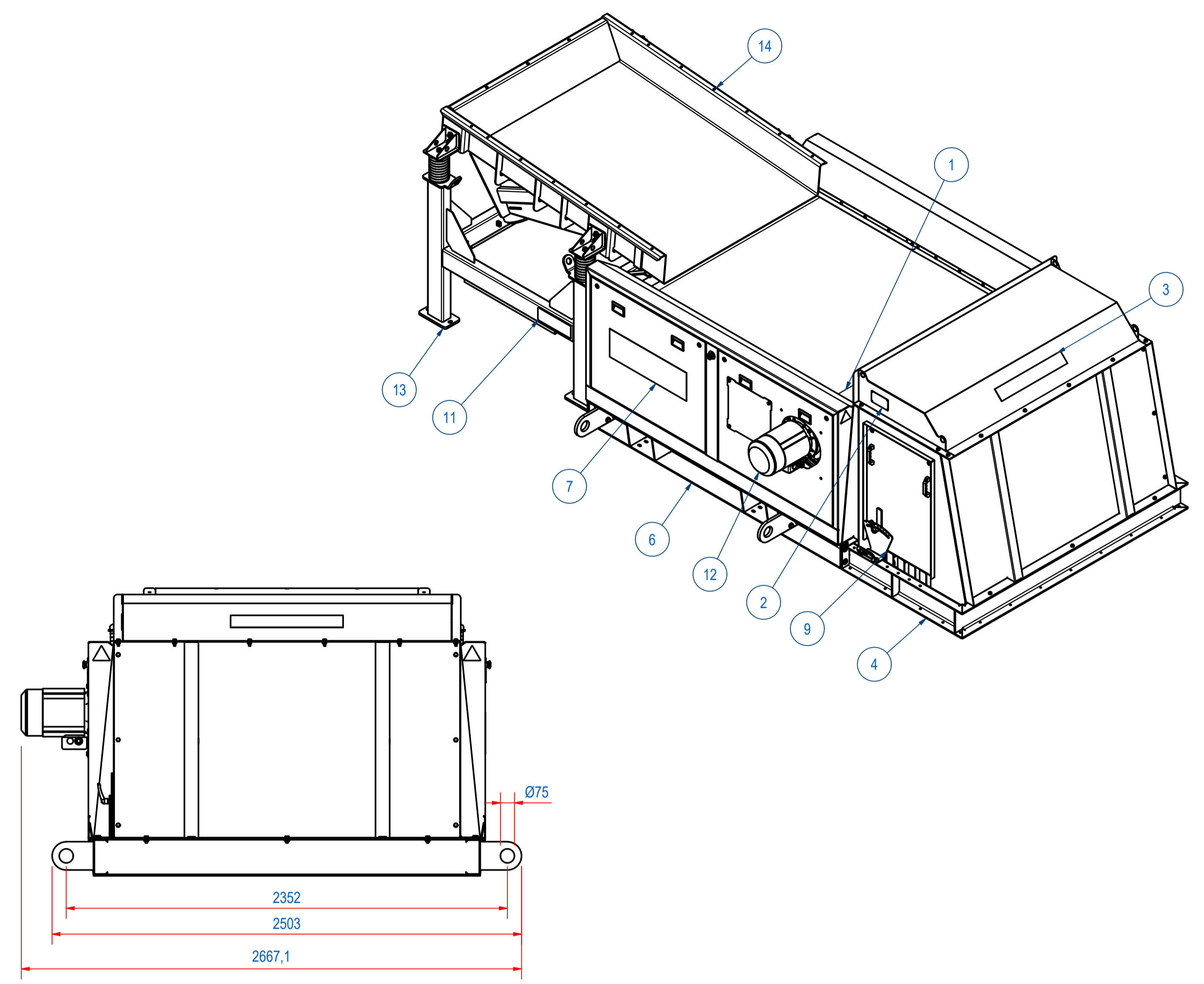
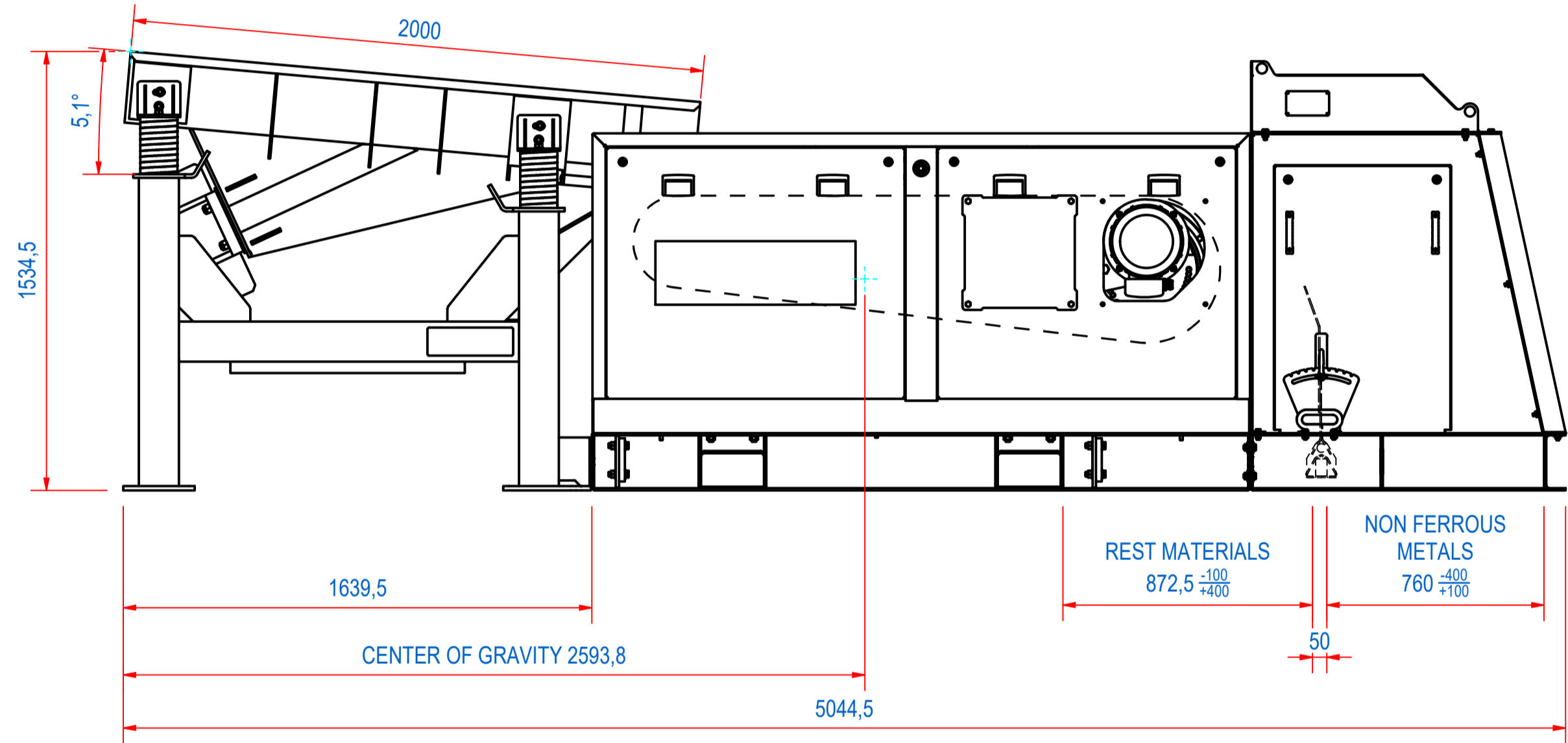
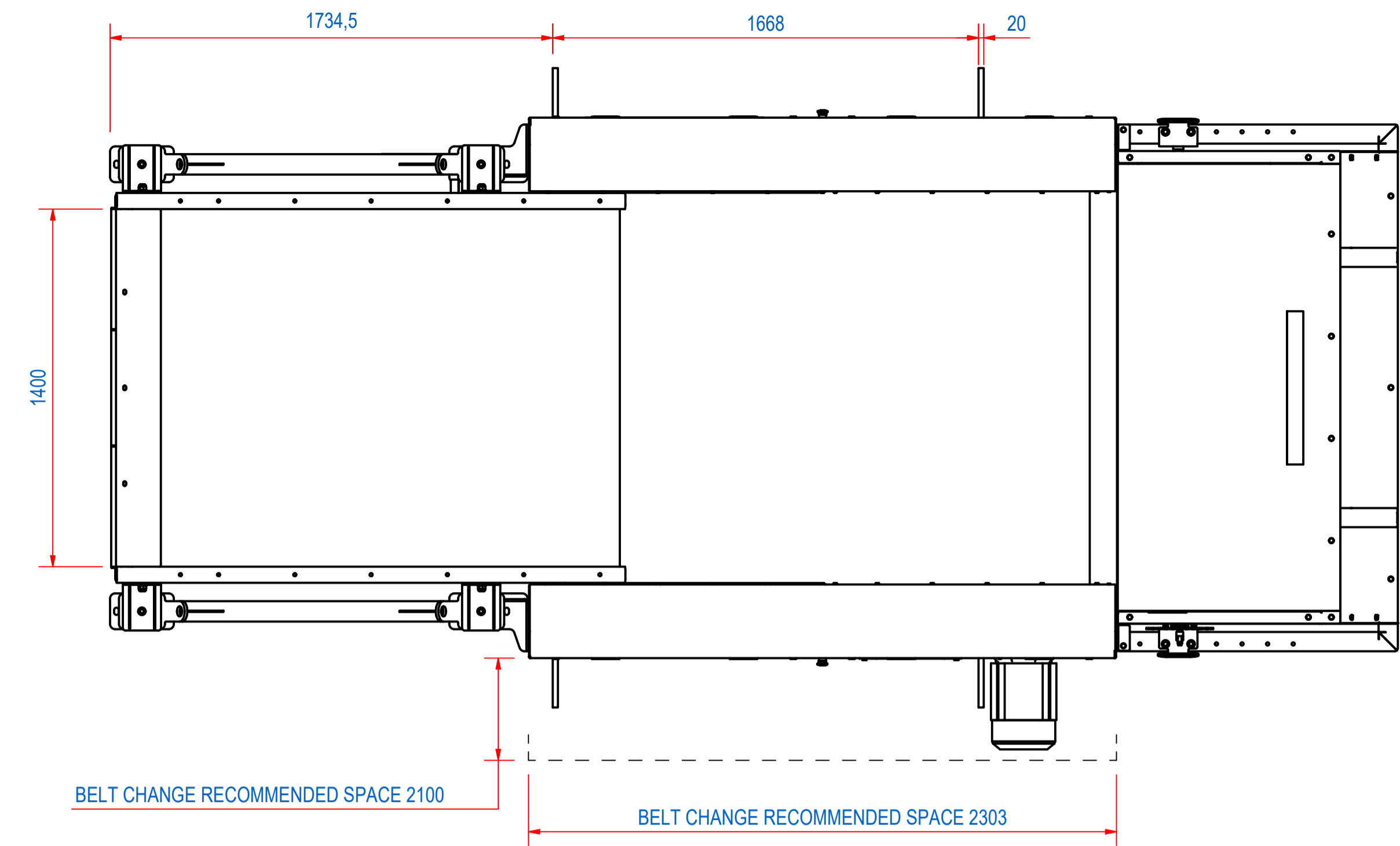

LAYOUT MOUNTING HOLES FUNNEL

RECOMMENDED FREE SPACE AROUND THE MACHINE FOR INSPECTION IS 800 MM

LAYOUT MOUNTING HOLES

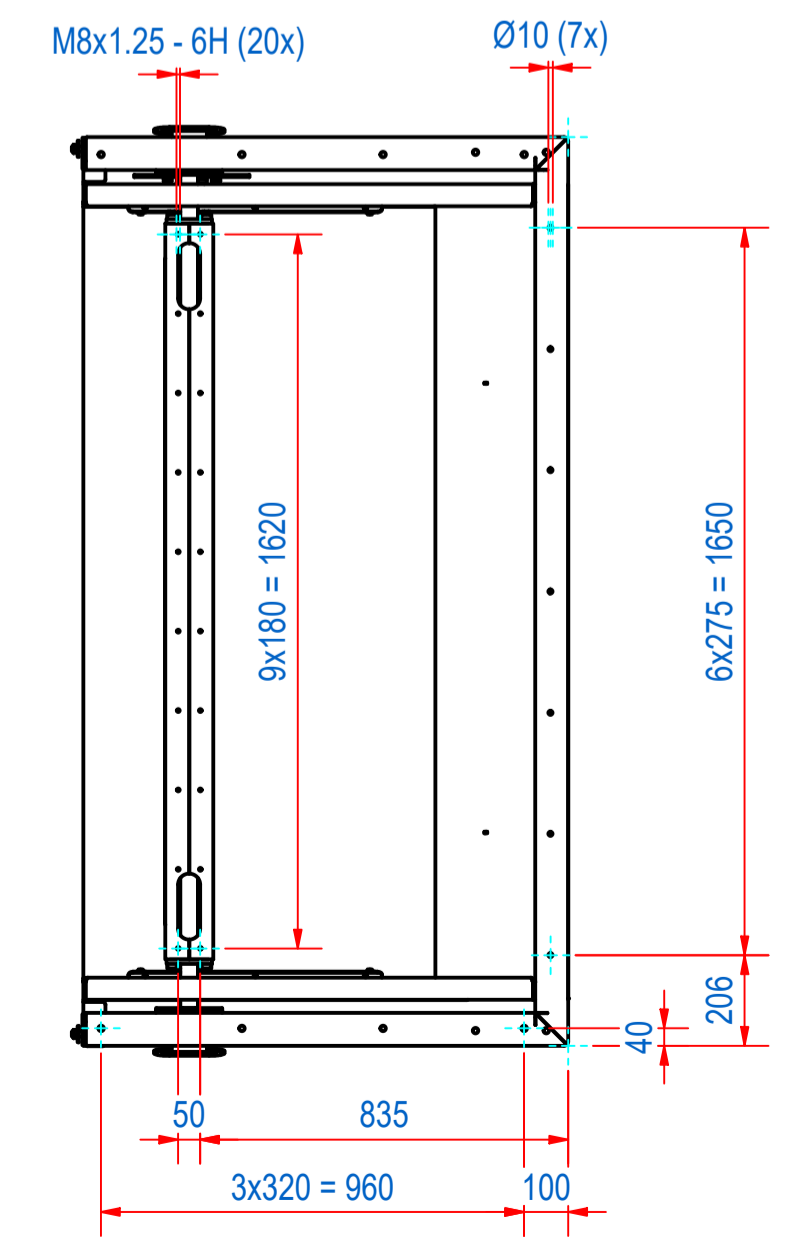
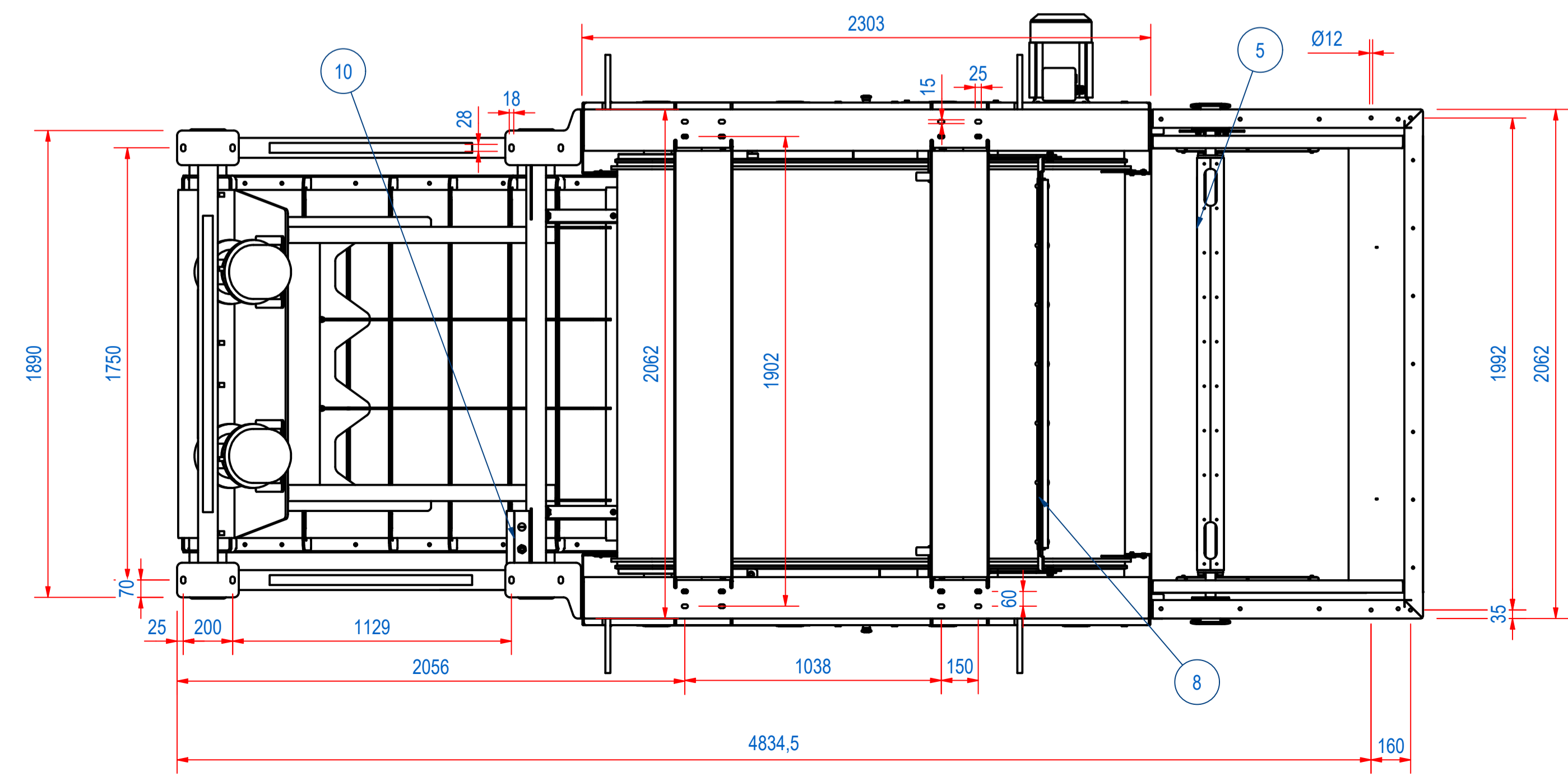

ELECTRICAL PROPERTIES  
CURRENT: 32 A  
POWER: 17,5 kVA

ITEM	QTY	PART NUMBER	DESCRIPTION	Dimensions
14	1	E0106804	RECV-VB-15-VM20-05-N	
13	1	E0060857	RECV-VF-15-N	
12	1	E0112456	RECM-15-E22HI	
11	2	E0129382	STICKER ECS HOISTING	
10	1	E0134050	RECV-CS-G-N	
9	1	E0075434	RECE-SA-M-B	
8	1	E0111557	RECE-BS-15-X-NBR	
7	2	E0120504	STICKER EDDYXPRT W700 H222 WHITE	
6	1	E0107821	RECE-EF-15-X-R	
5	1	E0107956	RECE-SP-15-S	
4	1	E0075432	RECE-SB-15-M-ST	
3	2	E0120519	STICKER GOUDSMIT MAG. W600 WHITE	
2	1	E0098479	DATA PLATE	
1	1	45.1800047	RECE-CB-15-X-PU-30	

RAW MAT.	Quantity	Material Number	Material Description	General tolerance:	Length (mm)	Width (mm)
1				ISO 2768 - mK		

Drawn: tt	Weight (kg): 3210	Source: MC-C	Quick search: REC-15	Description: REC-15-E22HI-N-MAB-SM-PU-R
Date: 12-10-2020	Sheet: A1	Website: WEBSITE MODEL	Drawn according to: ISO268; ISO1101; ISO2553	Status: Released
Customer reference number:			Document number: E0136511	Doc Rev: E0136511