

RECOMMENDED FREE SPACE AROUND THE MACHINE FOR INSPECTION IS 800 MM

LAYOUT MOUNTING HOLES

LAYOUT MOUNTING HOLES FUNNEL

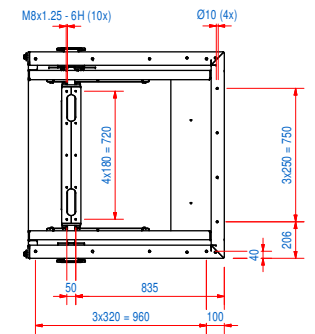
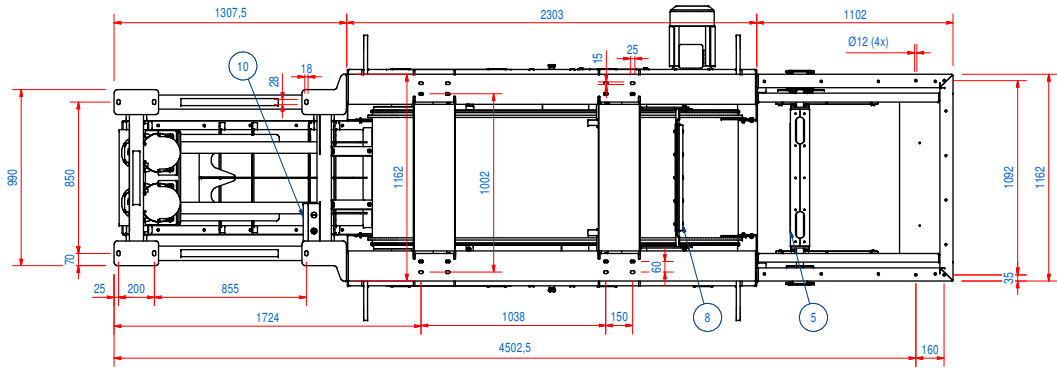

ITEM	QTY	PART NUMBER	DESCRIPTION	Dimensions
14	2	E0129382	STICKER ECS HOISTING	
13	1	E0115985	RECV-VB-06-VM16-05-N	
12	1	E0116264	RECV-VF-06-N	
11	2	E0120504	STICKER EDDYXPRT W700 H222 WHITE	
10	1	E0134050	RECV-CS-G-N	
9	1	E0116494	RECE-06-E22H1	
8	1	E0116552	RECE-BS-06-X-NBR	
7	1	E0116450	RECE-EF-06-X-R	
6	1	E0075434	RECE-SA-M-B	
5	1	E0116579	RECE-SP-06-S	
4	2	E0120519	STICKER GOUDSMIT MAG. W600 WHITE	
3	1	E0116594	RECE-SB-06-M-ST	
2	1	E0098479	DATA PLATE	
1	1	E0116490	RECE-CB-06-X-PU-30	

RAW MAT.	Quantity	Material Number	Material Description	Length (mm)	Width (mm)
1	1				

Sheet: A1
 Drawn according to: ISO 2768- mK
 Date: 21-10-2020
 Drawn by: MC-C
 Source: MC-C
 Spare part: FALSE
 Quick search: REC-06
 Description: REC-06-E22H1-N-MAB-SM-PU-R

General tolerance: ISO 2768- mK
 Drawn according to: ISO 2688, ISO 1101, ISO 2553
 Status: Work in Progress
 Customer reference number:
 Document number: E0136829
 Part number: E0136829

ELECTRICAL PROPERTIES
CURRENT: 20 A
POWER: 11,7 KVA