

| DOC.NR. | REV | DATE | BY | DESCRIPTION |
|----------|-----|------|----|------------------|
| E0115698 | - | | | ORIGINAL DRAWING |

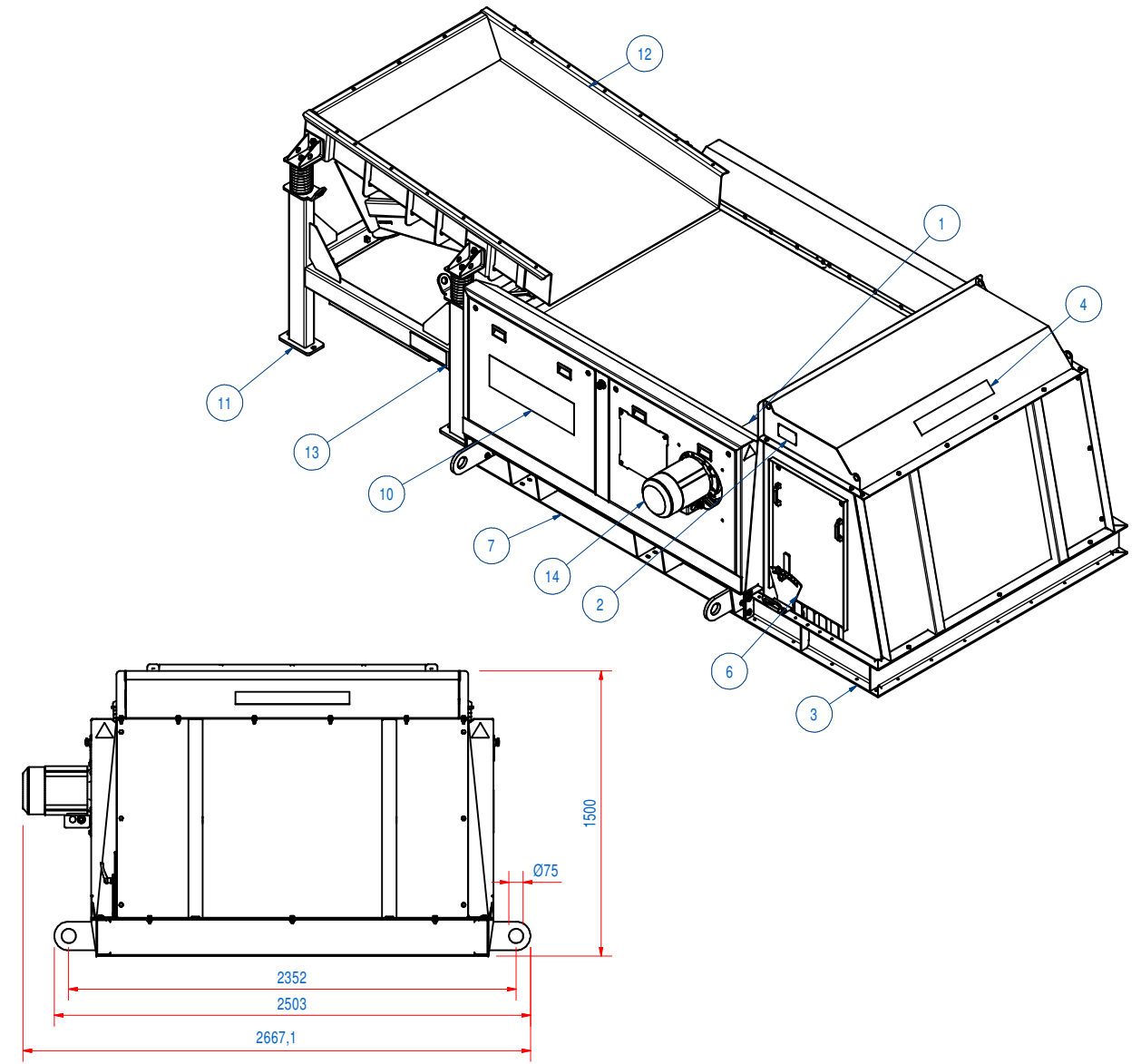

RECOMMENDED FREE SPACE AROUND THE MACHINE FOR INSPECTION IS 800 MM

LAYOUT MOUNTING HOLES

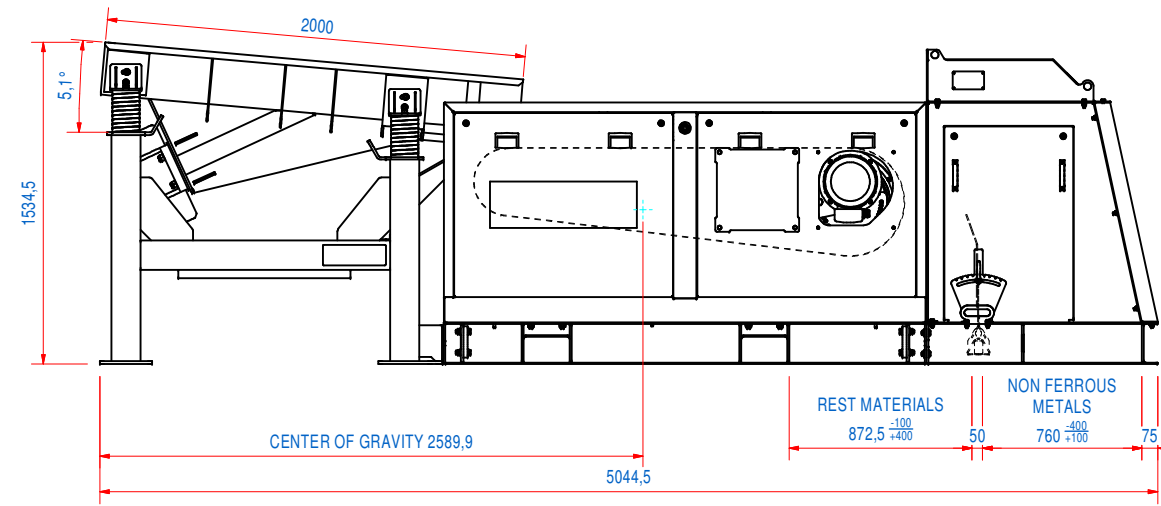
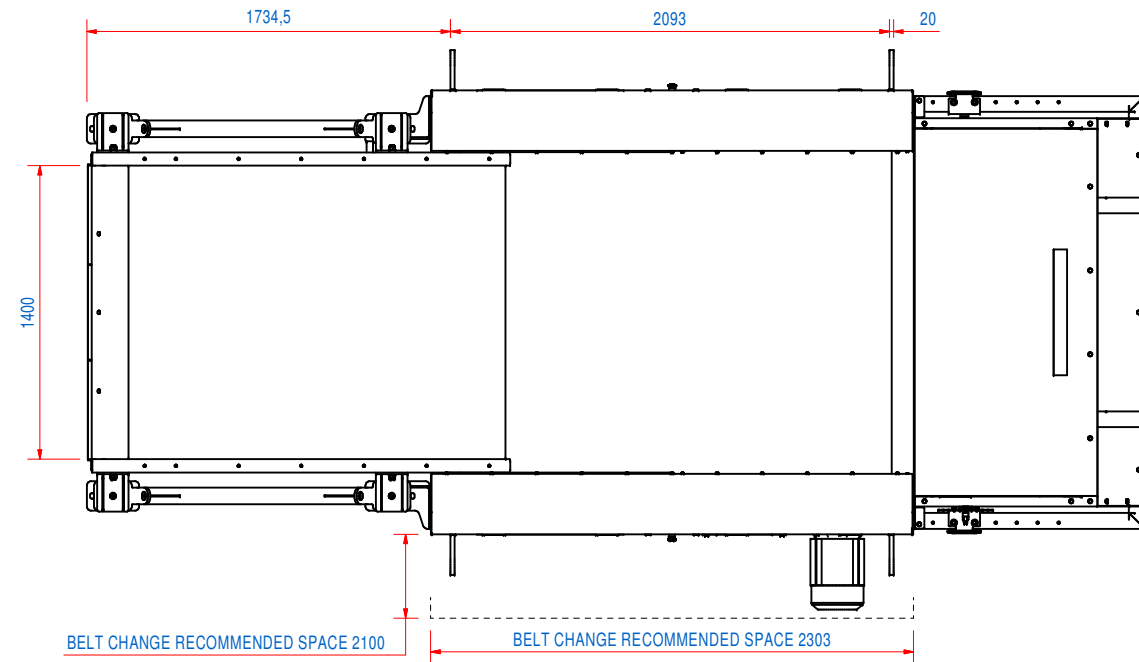
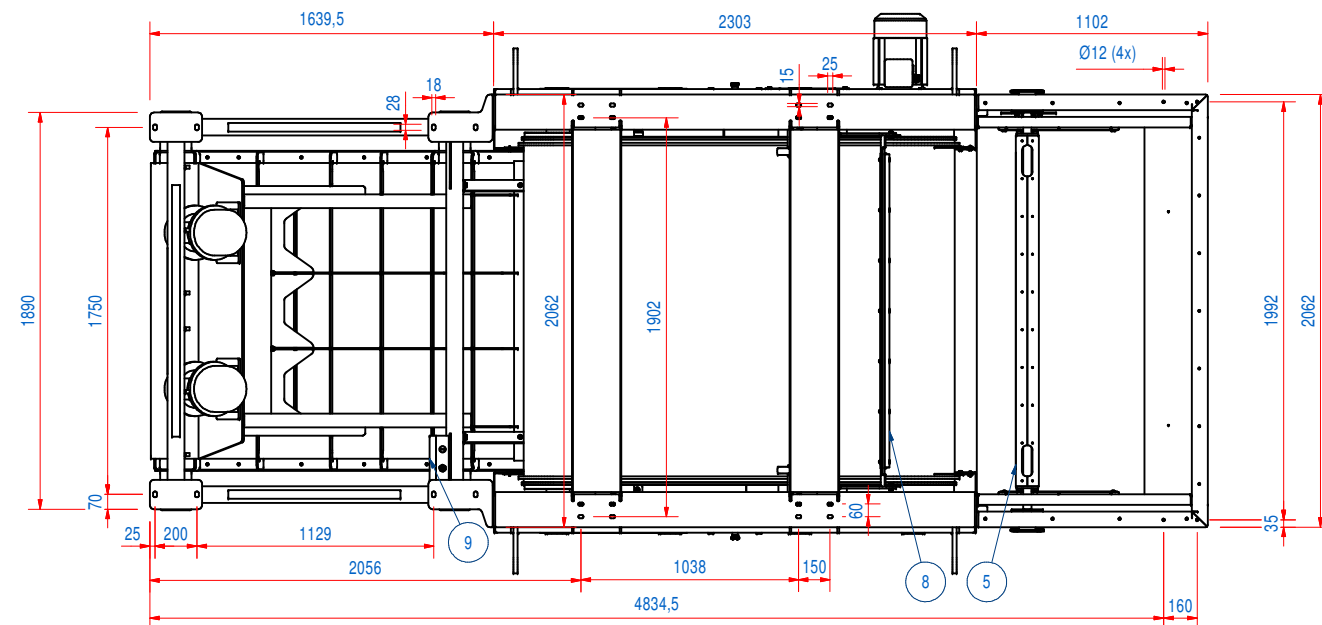

LAYOUT MOUNTING HOLES FUNNEL

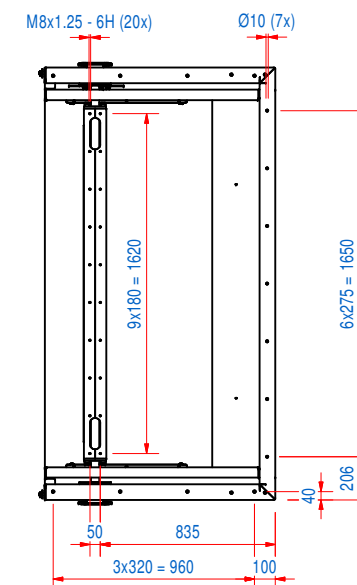

ELECTRICAL PROPERTIES
CURRENT: 32 A
POWER: 17,5 KVA

| ITEM | QTY | PART NUMBER | DESCRIPTION | Dimensions |
|------|-----|-------------|----------------------------------|------------|
| 14 | 1 | E0112461 | RECM-15-E12 | |
| 13 | 2 | E0129382 | STICKER ECS HOISTING | |
| 12 | 1 | E0106804 | RECV-VB-15-VM20-05-N | |
| 11 | 1 | E0060857 | RECV-VF-15-N | |
| 10 | 2 | E0120504 | STICKER EDDYXPRT W700 H222 WHITE | |
| 9 | 1 | E0134050 | RECV-CS-G-N | |
| 8 | 1 | E0111557 | RECE-BS-15-X-NBR | |
| 7 | 1 | E0107821 | RECE-EF-15-X-R | |
| 6 | 1 | E0075434 | RECE-SA-M-B | |
| 5 | 1 | E0107956 | RECE-SP-15-S | |
| 4 | 2 | E0120519 | STICKER GOUDSMIT MAG. W600 WHITE | |
| 3 | 1 | E0075432 | RECE-SB-15-M-ST | |
| 2 | 1 | E0098479 | DATA PLATE | |
| 1 | 1 | 45.1800047 | RECE-CB-15-X-PU-30 | |

| RAW MAT. | Quantity | Material Number | Material Description | Length (mm) | Width (mm) |
|----------|----------|-----------------|----------------------|-------------|------------|
| 1 | 1 | | | | |

| | | | | |
|---------------------------------------|---|--------------|-----------------------|---|
| Drawn: TT | Weight (kg): 3395 | Sheet: A1 | WEBSITE MODEL | General tolerance: ISO 2768- mK |
| Date: 27-10-2020 | Spare part: False | Source: MC-G | GOUDSMIT MAGNETICS | Drawn according: ISO268; ISO1101; ISO2553 |
| Quick search: REC-15 | © All rights reserved. Reproduction is not permitted without written permission of GOUDSMIT Magnetic Systems BV | | | Status: Work in Progress |
| Description: REC-15-E12-N-MAB-SM-PU-R | Document number: E0115698 | Doc.Rev: | Part number: E0136904 | Rev: |