

RECOMMENDED FREE SPACE AROUND THE MACHINE FOR INSPECTION IS 800 MM

LAYOUT MOUNTING HOLES

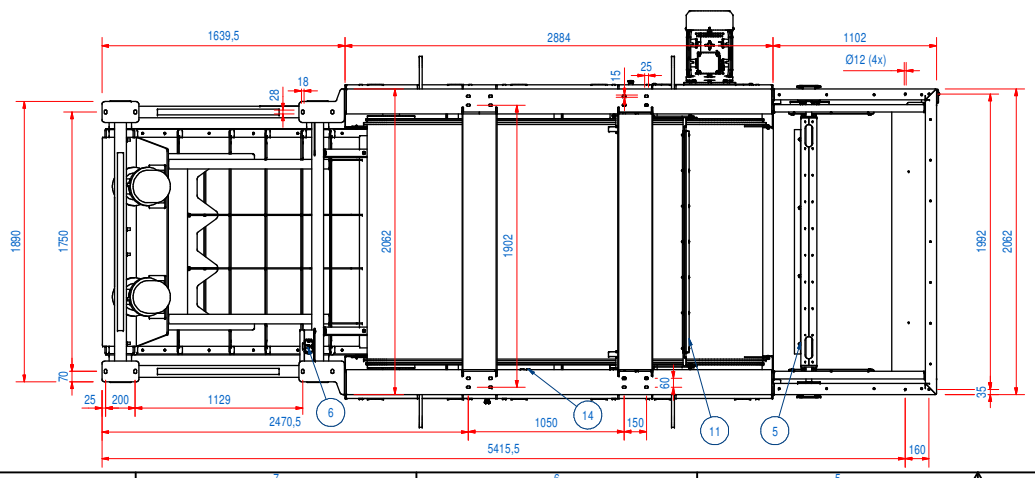

LAYOUT MOUNTING HOLES FUNNEL

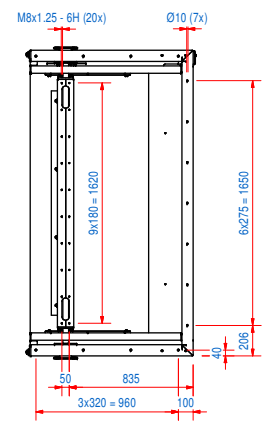

ITEM	QTY	PART NUMBER	DESCRIPTION	Dimensions
15	1	E0108037	RECE-SA-S-R	
14	1	E0109220	RECE-CS-C	
13	2	E0120506	STICKER EDDYFINES W700 H222 WHITE	
12	1	A280329	RECM-15-E38H	
11	1	E0111559	RECE-BS-15-F-NBR	
10	1	E0107864	RECE-EF-15-F-R	
9	2	E0129382	STICKER ECS HOISTING	
8	1	E0106804	RECV-VB-15-VM20-05-N	
7	1	E0060857	RECV-VF-15-N	
6	1	E0134176	RECV-CS-C-N	
5	1	E0108097	RECE-SP-15-FM	
4	2	E0120519	STICKER GOUDSMIT MAG. W600 WHITE	
3	1	E0075432	RECE-SB-15-M-ST	
2	1	E0098479	DATA PLATE	
1	1	45.1800085	RECE-CB-15-F-PU-24	

RAW MAT.	Quantity	Material Number	Material Description	Length (mm)	Width (mm)
Sheet	A1	Extra info: WEBSITE		General tolerance: ISO 2768- mK	
Drawn	TT	Weight (kg)	4230	Drawn according: ISO2688, ISO1101, ISO2553	
Date:	27-10-2020	Source:	MC-C	Status: Work in Progress	
Spare part:	False	Customer reference number:		Document number: E0115698	
Quick search:	REC-15	Part number:		Disc Nav: E0136908	
Description:	REC-15-E38HI-N-MAB-FMS-PU-R	Part number:	E0136908	Rev: 1	

ELECTRICAL PROPERTIES  
CURRENT: 35 A  
POWER: 22.9 KVA