

3	2	1		
DOC.NR.	REV	DATE	BY	DESCRIPTION
E0142883	-	30-6-2021	AvD	REFERENCE DRAWING E0015745

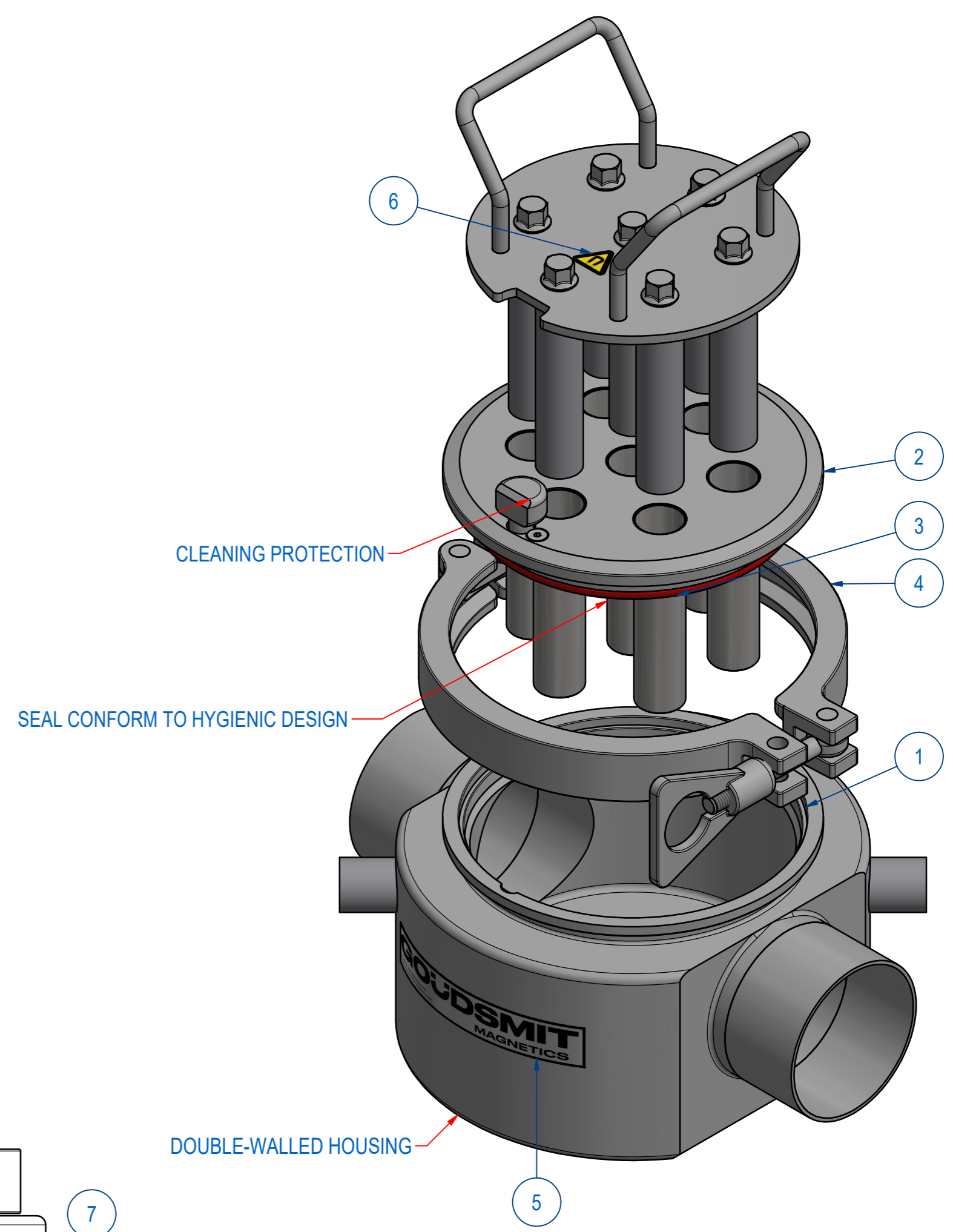
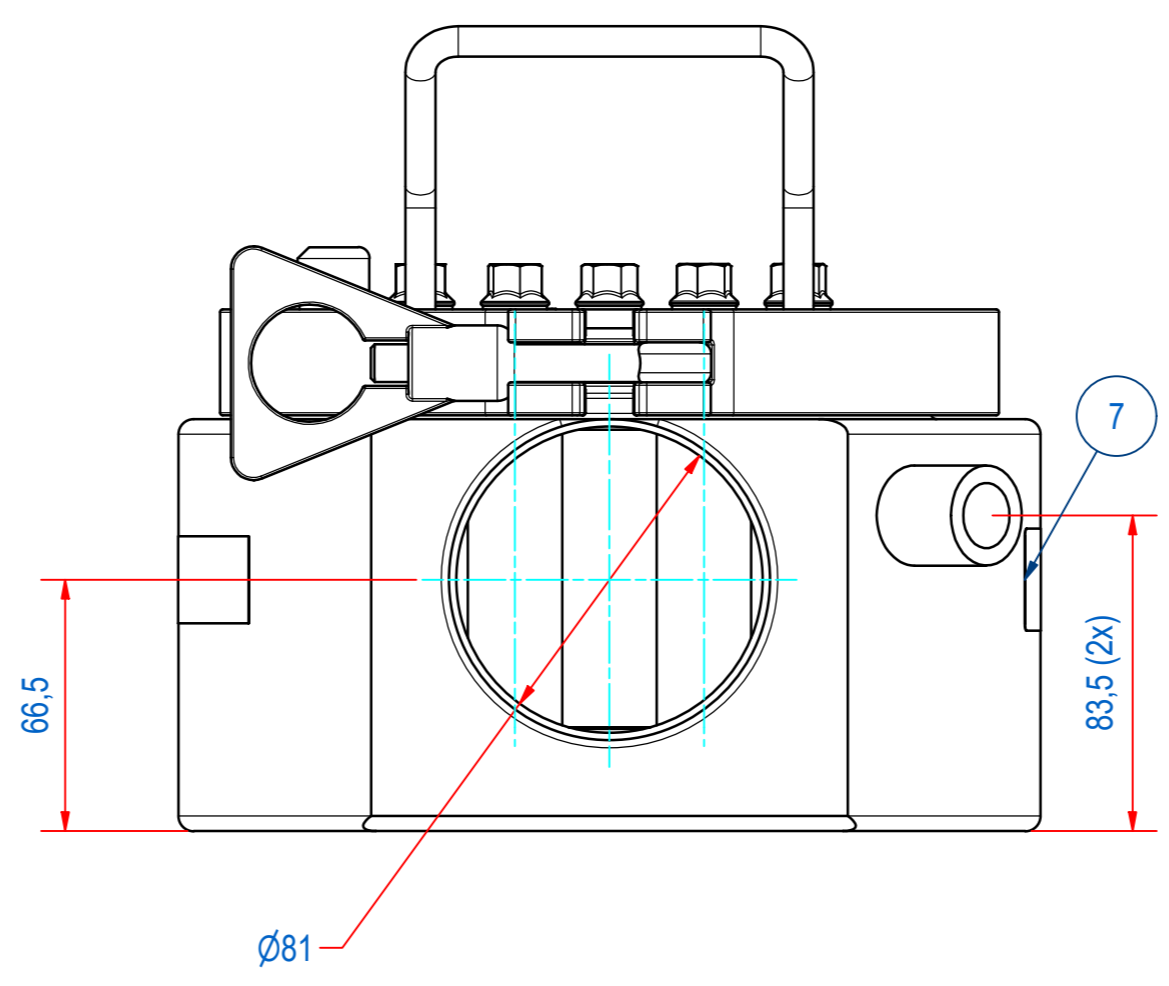
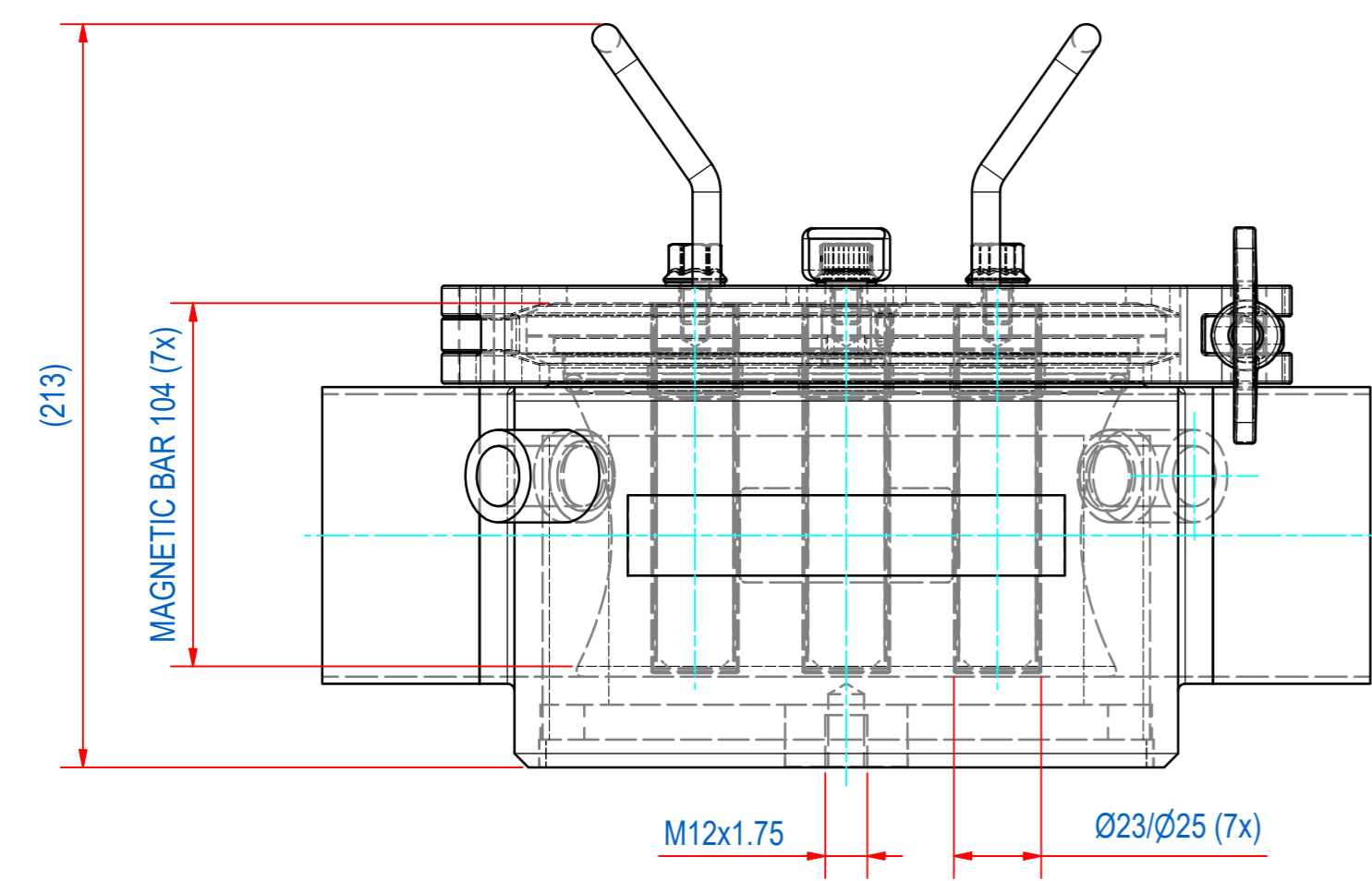
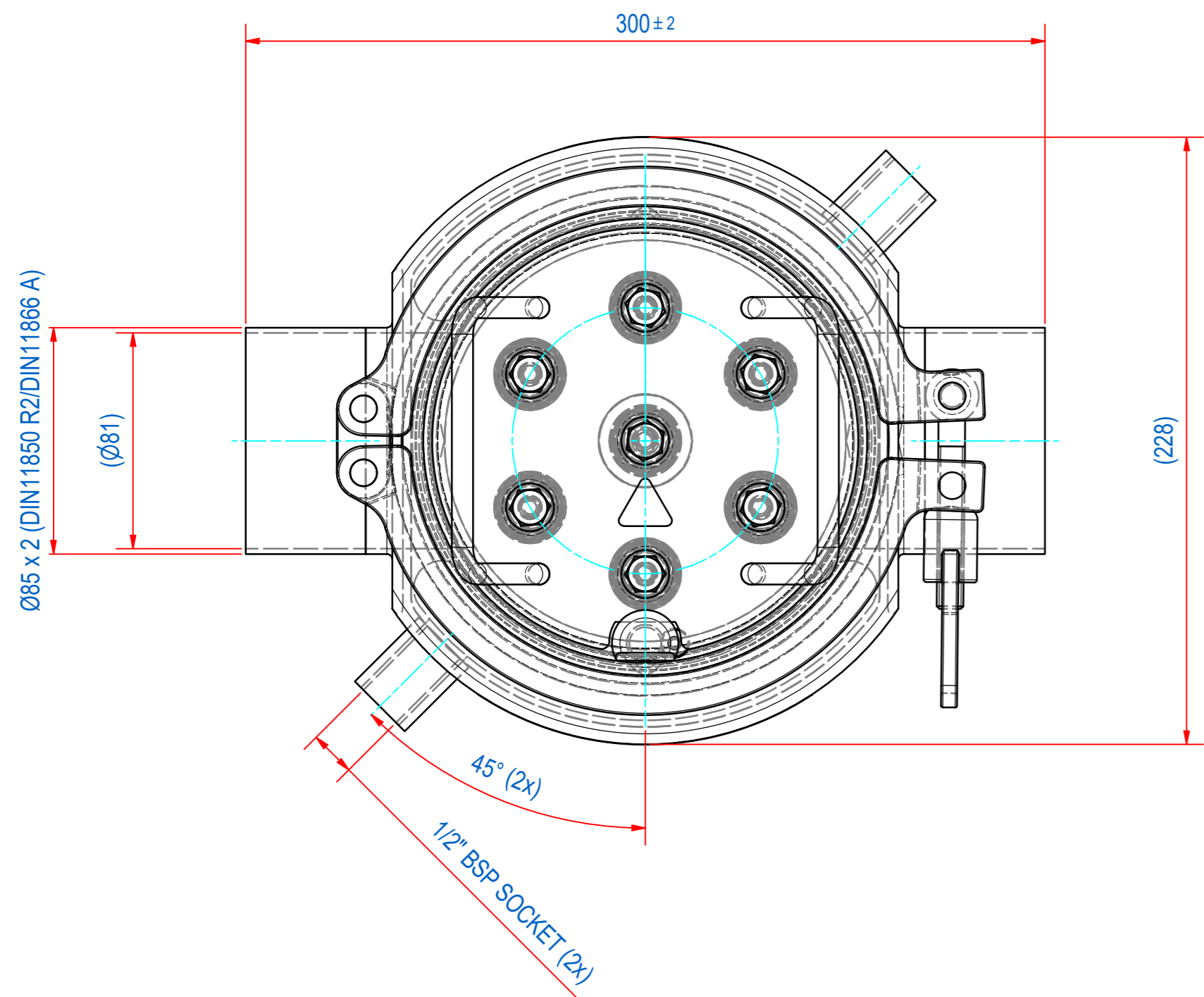

ITEM	QTY	PART NUMBER	DESCRIPTION	Dimensions
7	1	E0146494	TYPE PLATE FILTER SFHD	
6	1	1000.20080	STICKER MAGNETIC FIELD 20mm	
5	1	E0146491	STICKER SFHD GSM D228	
4	1	77.9630140	GPFI-TRI CLAMP Ø183	
3	1	E0018393	SFH-S-000-S O-RING RED EC1935	
2	1	E0015752	SFH-SPARE-080-07E-HT FILTER TOP	
1	1	E0143339	SFHD-080-T1 HOUSE 316L	

RAW MAT.	Quantity	Material Number	Material Description	Length (mm)	Width (mm)
7	1	E0146494	TYPE PLATE FILTER SFHD		

Sheet: <b>A2</b> Drawn: <b>AvD</b> Date: <b>17-5-2021</b> Spare part: <b>False</b> Quick search: <b>SFHD-080</b>	Extra info: Weight (kg): <b>21</b> Source: Description: <b>SFHD-080-T1-07E-HT-F5M-S-B-B</b>	General tolerance: <b>ISO 2768 - mK</b> Drawn according: <b>ISO268; ISO1101; ISO2553</b> Status: <b>Released</b> Customer reference number: Document number: <b>E0142883</b> Part number: <b>E0142883</b>
--	--	--