

3	2	1		
DOC.NR.	REV	DATE	BY	DESCRIPTION
E0146471	-	21-9-2021	AvD	REFERENCE DRAWING E0015745

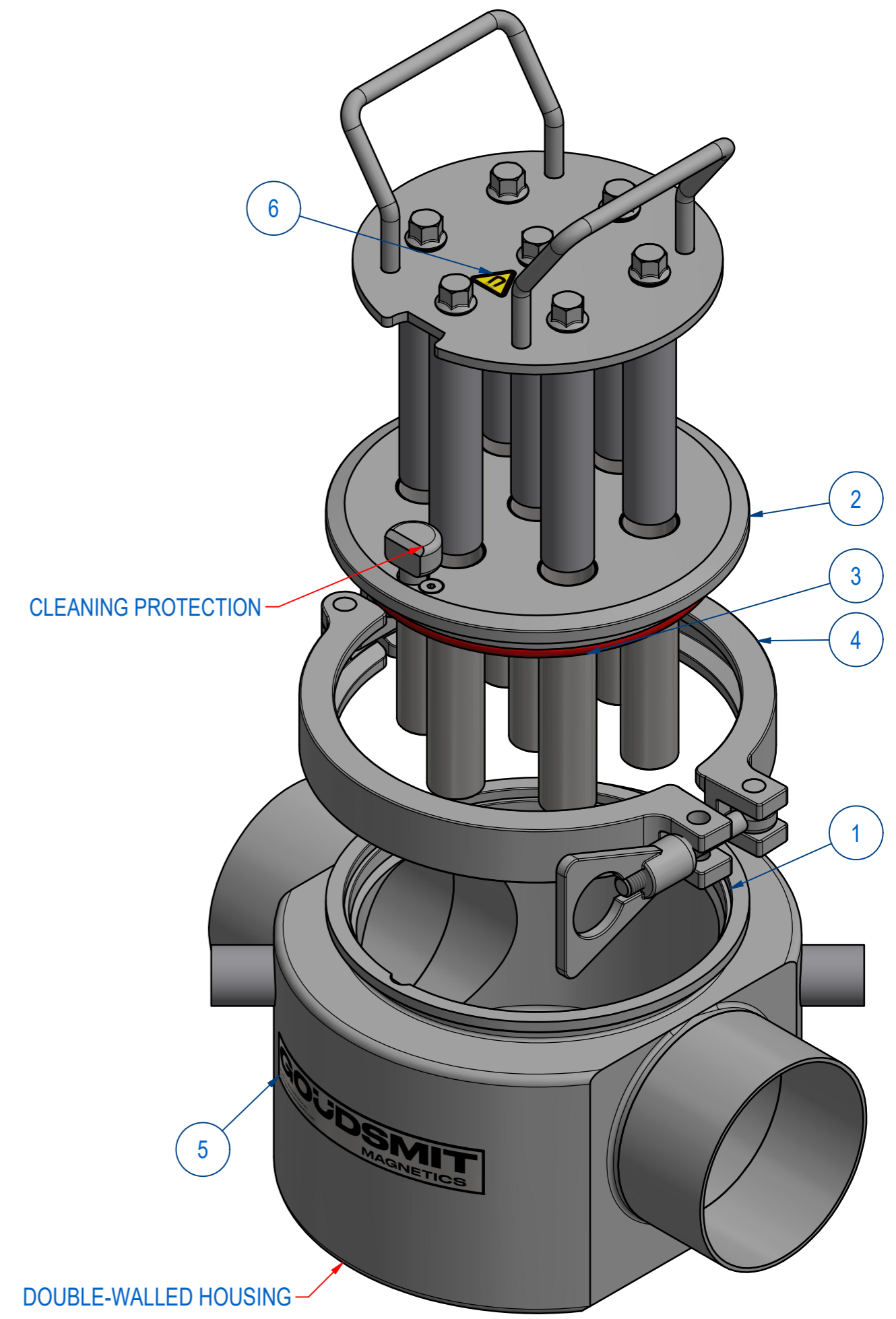
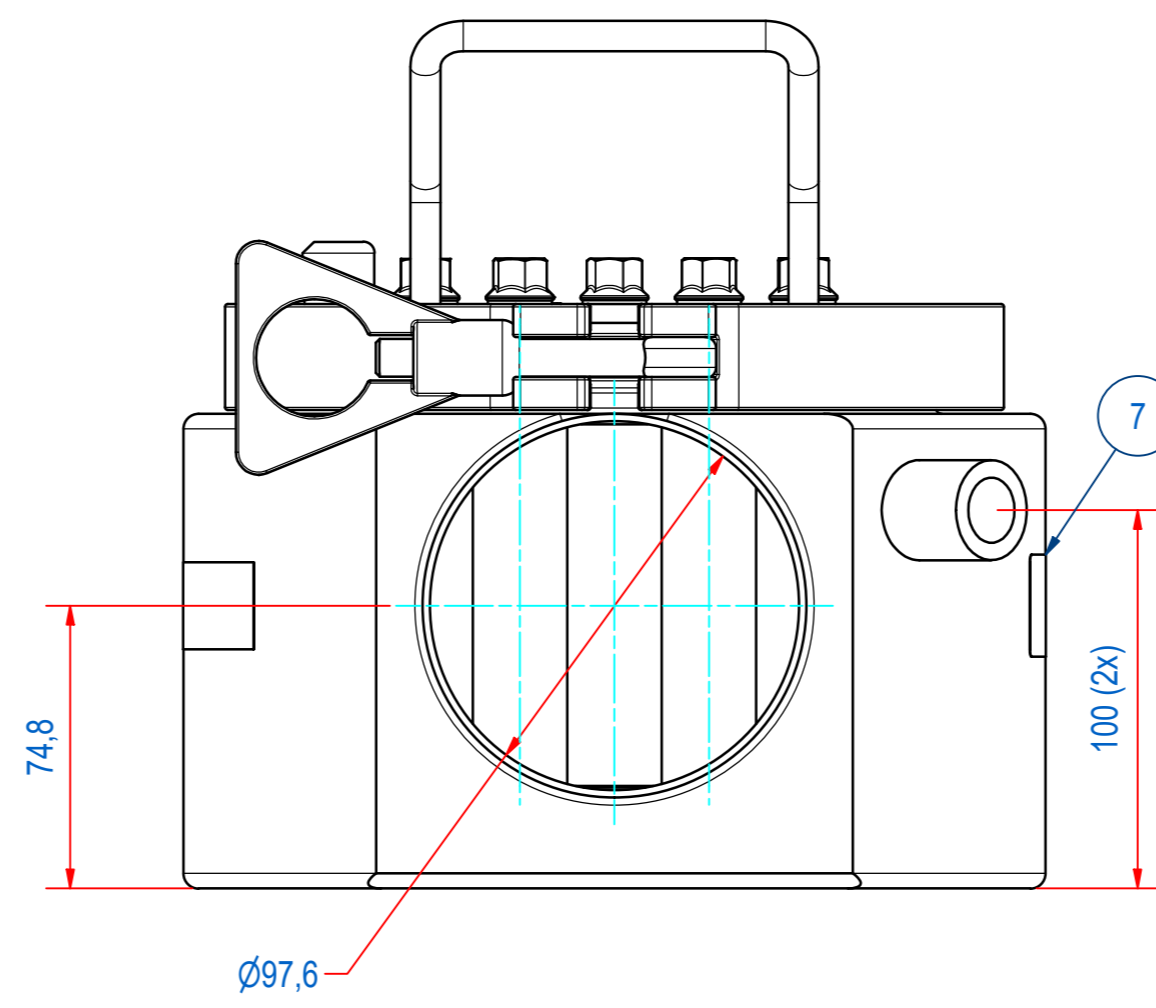
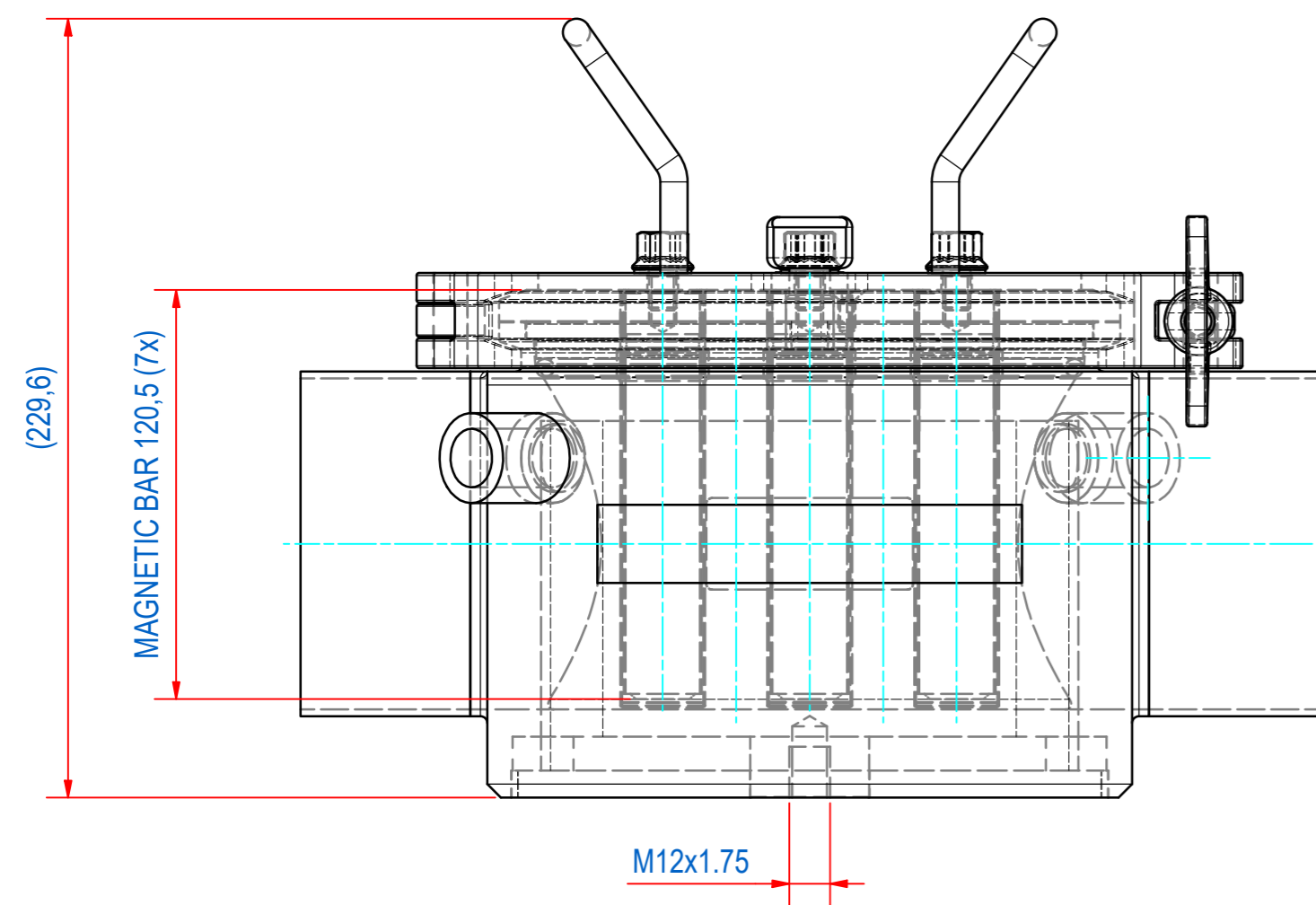
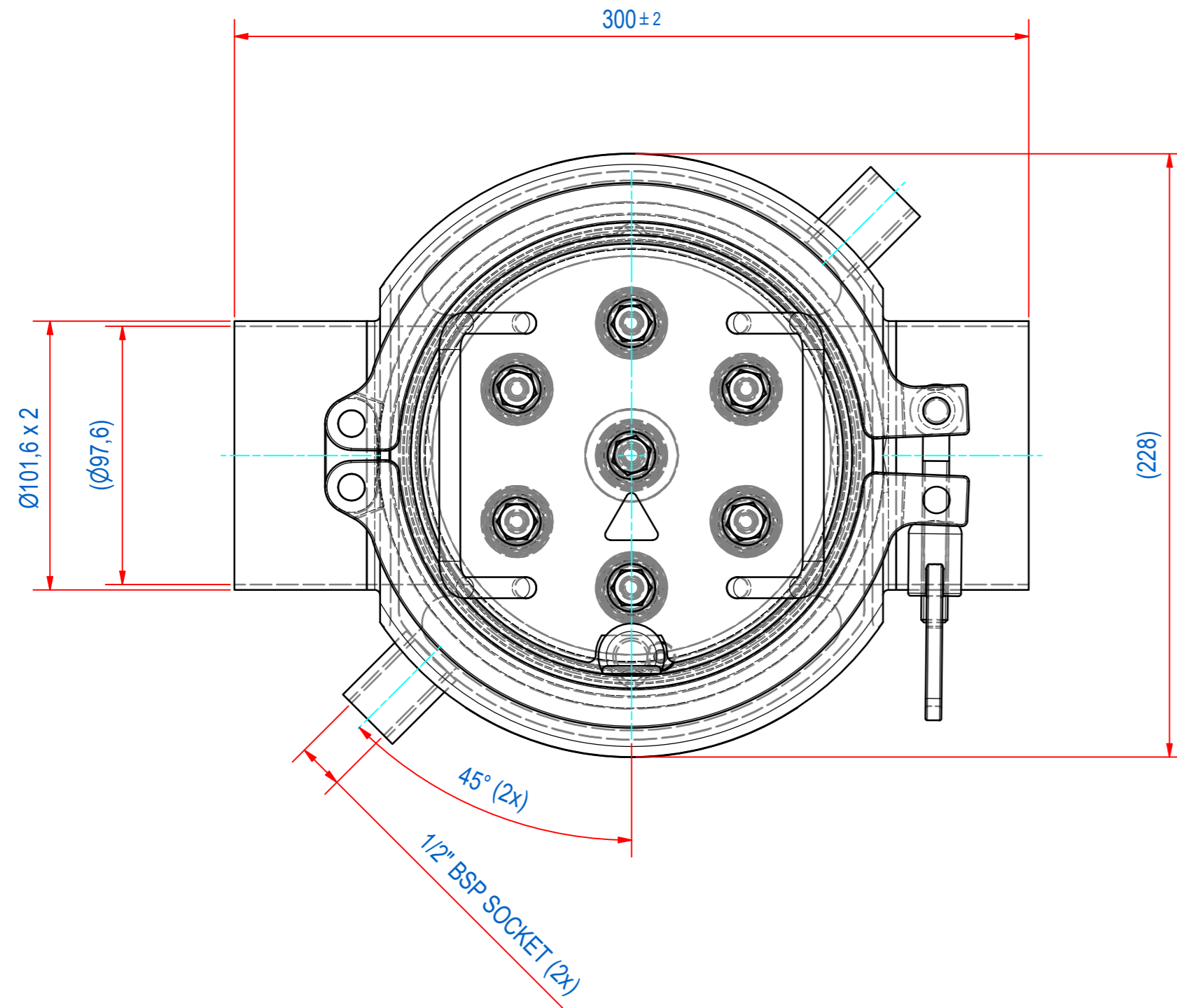

ITEM	QTY	PART NUMBER	DESCRIPTION	Dimensions
7	1	E0146494	TYPE PLATE FILTER SFHD	
6	1	1000.20080	STICKER MAGNETIC FIELD 20mm	
5	1	E0146491	STICKER SFHD GSM D228	
4	1	77.9630140	GPII-TRI CLAMP Ø183	
3	1	E0018393	SFH-S-000-S O-RING RED EC1935	
2	1	E0019381	SFH-SPARE-4"-07E-HT FILTER TOP	
1	1	E0146472	SFHD-4"-T2 HOUSE 316L	

RAW MAT.	Quantity	Material Number	Material Description	Length (mm)	Width (mm)
1	1				

Sheet: A2	Extra info: MAGNETIC FILTER	General tolerance: ISO 2768 - mK
Drawn: AvD	Weight (kg): 23	Drawn according: ISO268; ISO1101; ISO2553
Date: 21-9-2021		Status: Released
Spare part: False	Source:	Customer reference number:
Quick search: SFHD-4"		
Description: SFHD-4"-T2-07E-HT-F5M-S-B-B	Document number: E0146471	Doc.Rev: -
	Part number: E0146471	Rev: -