

REV	DATE	BY	DESCRIPTION
-	24-9-2021	AvD	REFERENCE DRAWING E0016970

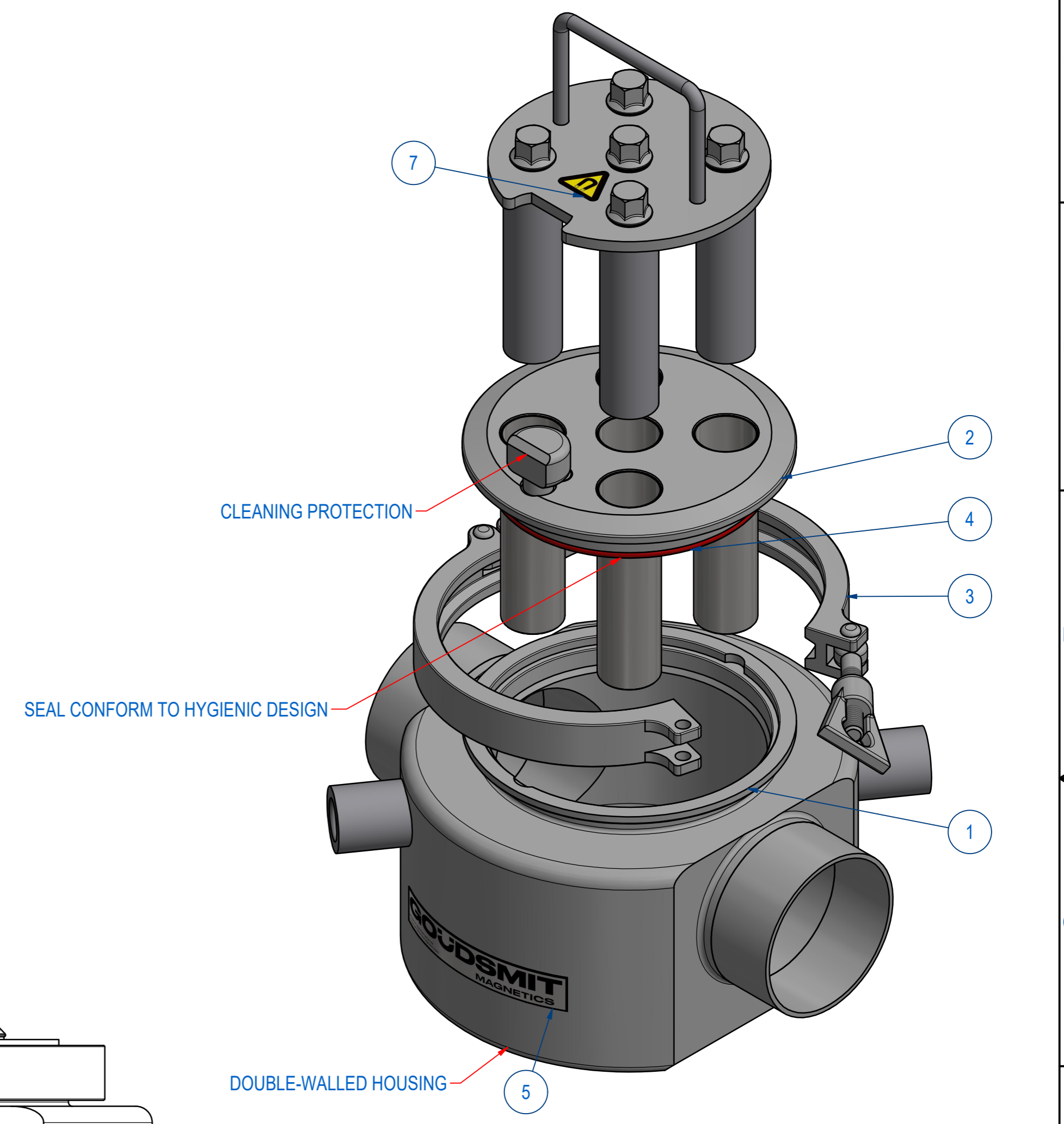
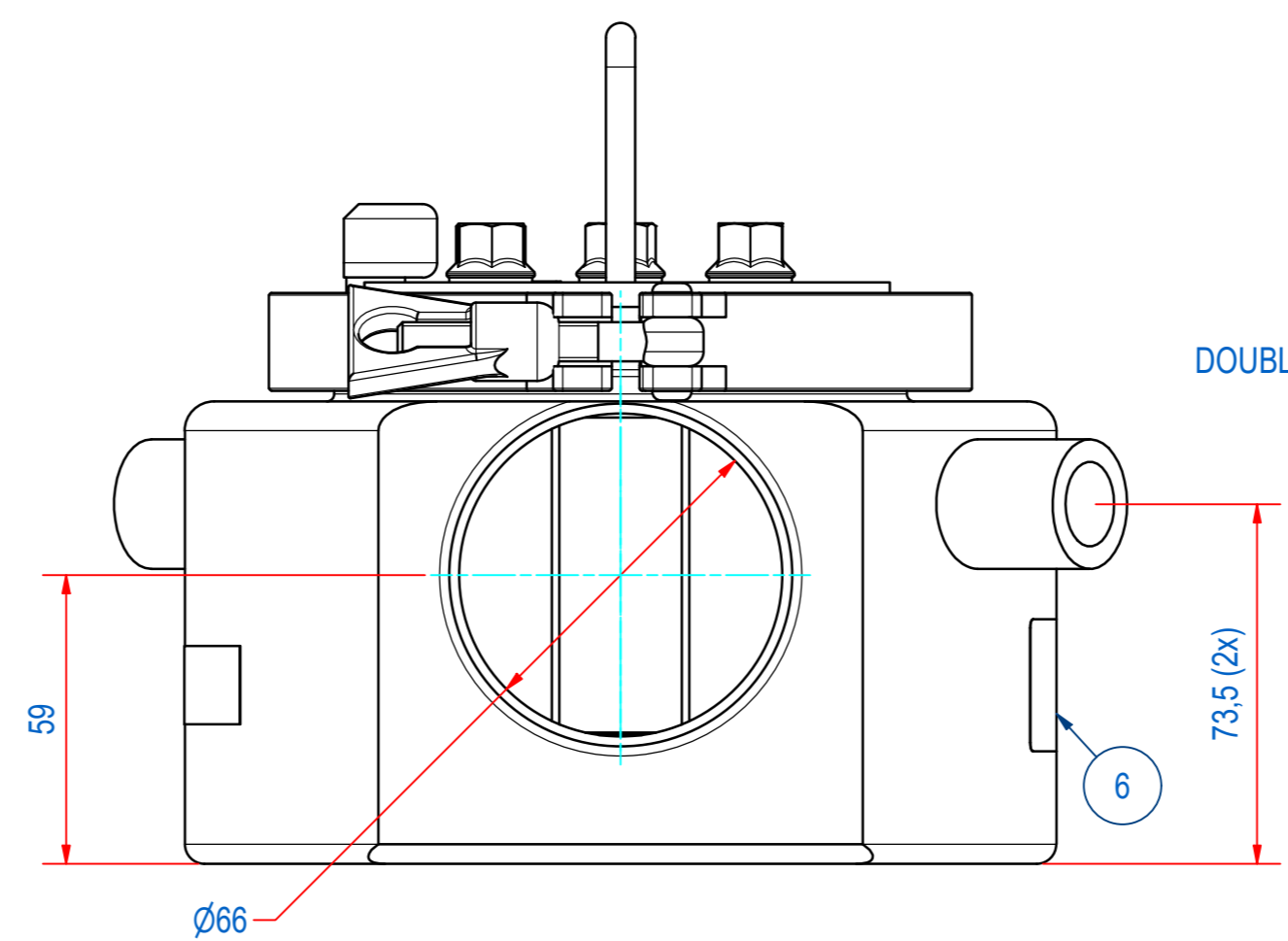
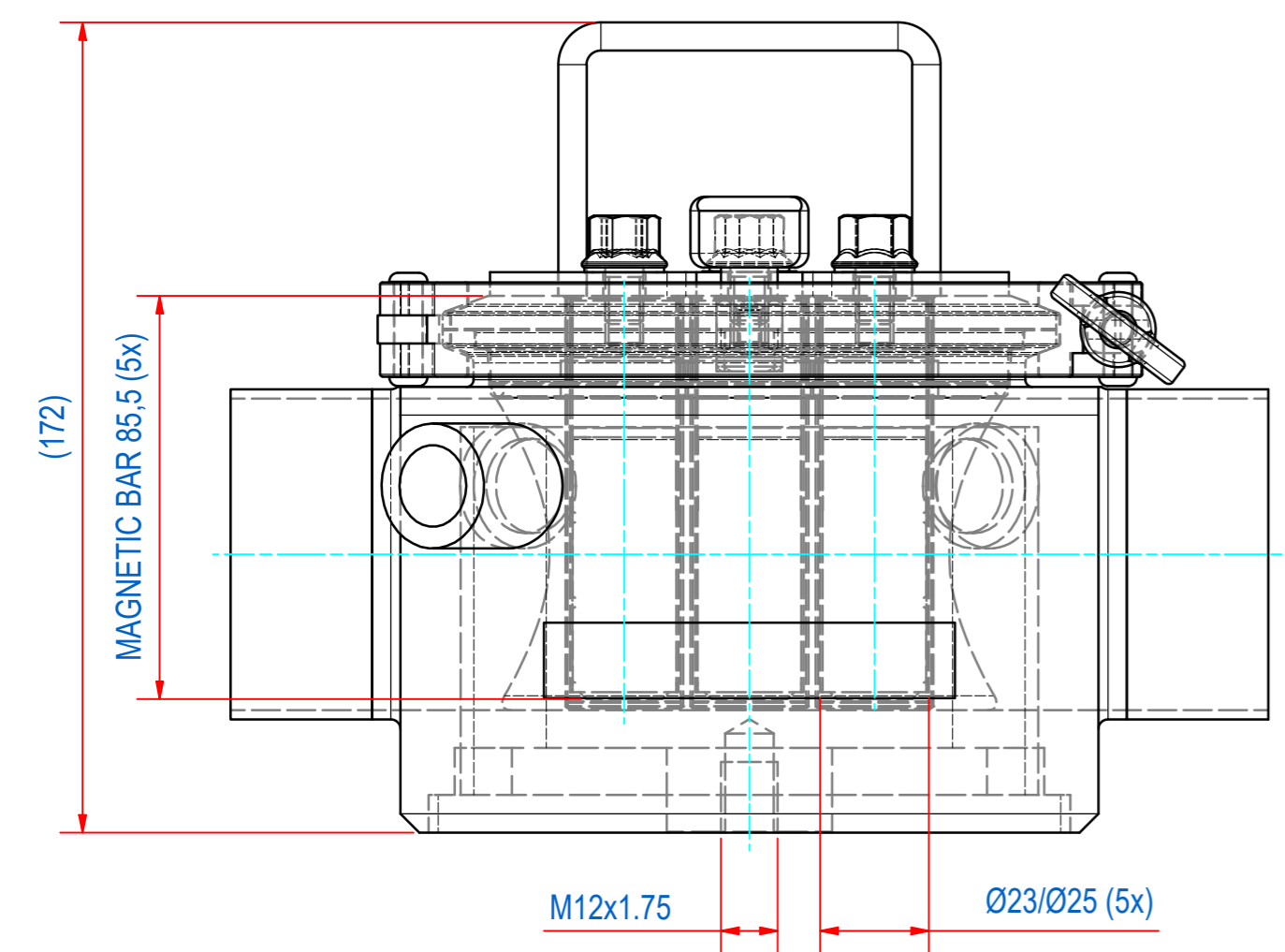
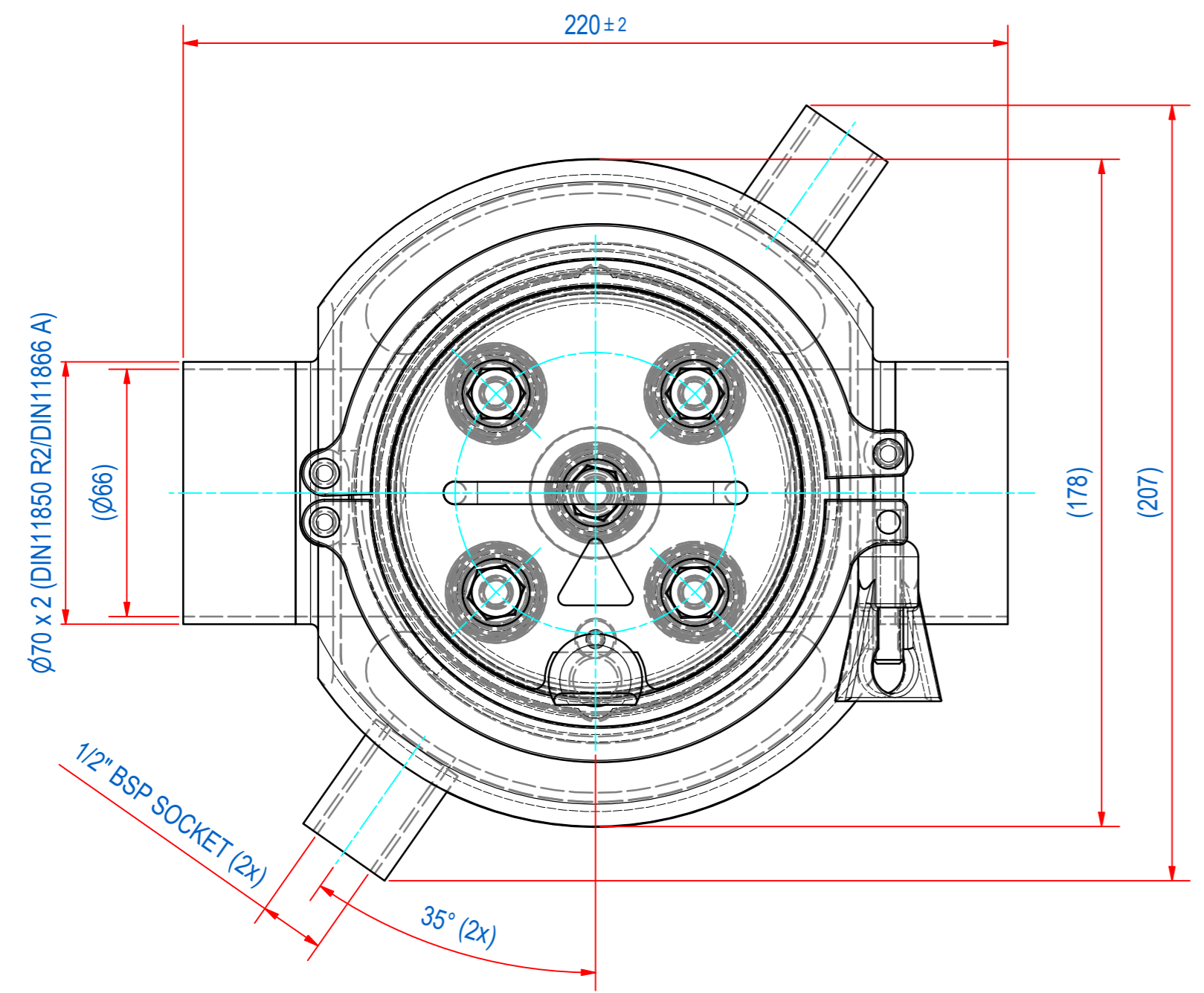

ITEM	QTY	PART NUMBER	DESCRIPTION	Dimensions
7	1	1000.20080	STICKER MAGNETIC FIELD 20mm	
6	1	E0146640	TYPE PLATE FILTER SFHD	
5	1	E0146639	STICKER SFHD GSM D178	
4	1	E0017388	SFH-S-000-S O-RING RED EC1935	
3	1	77.9630092	GPFi-TRI CLAMP Ø130	
2	1	E0013725	SFH-SPARE-065-05E-HT FILTER TOP	
1	1	E0146647	SFHD-065-T1 HOUSE 316L	

RAW MAT.	Quantity	Material Number	Material Description	Length (mm)	Width (mm)
1	1				

Sheet: A2	Extra info: MAGNETIC FILTER	General tolerance: ISO 2768 - mK
Drawn: AvD	Weight (kg): 11	Drawn according: ISO268; ISO1101; ISO2553
Date: 24-9-2021		Status: Released
Spare part: False		Customer reference number:
Quick search: SFHD-065		
Description: SFHD-065-T1-05E-HT-F5M-S-B-B	Document number: E0146644	Doc.Rev: -
	Part number: E0146644	Rev: -