

REV	DATE	BY	DESCRIPTION
-	30-6-2022	TT	REFERENCE DRAWING E0015853
A	7-6-2023	CR	WASHER M8 - A4 REPLACED BY WASHER 3xd M8x24 - A4 (ITEM 11)

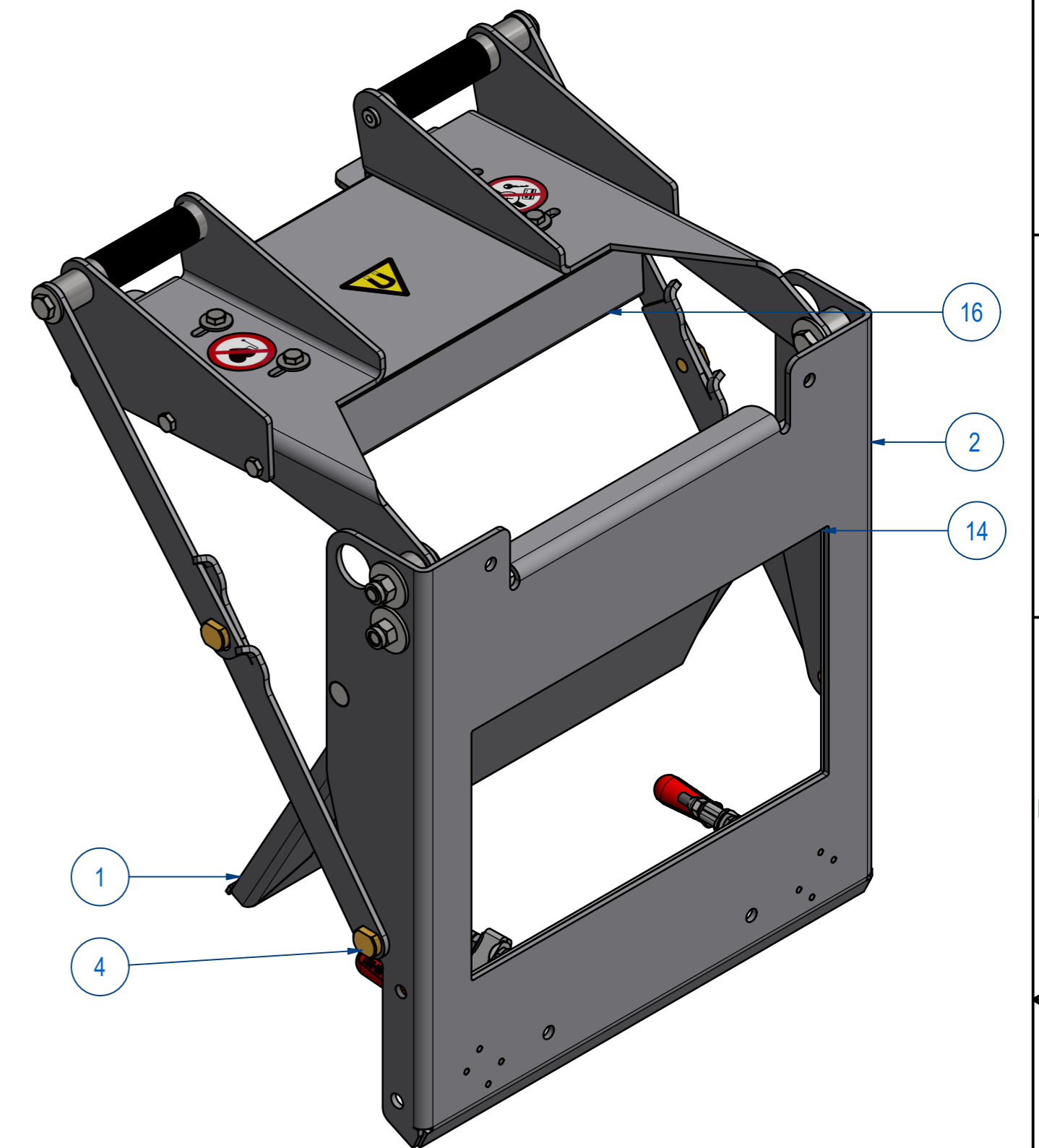
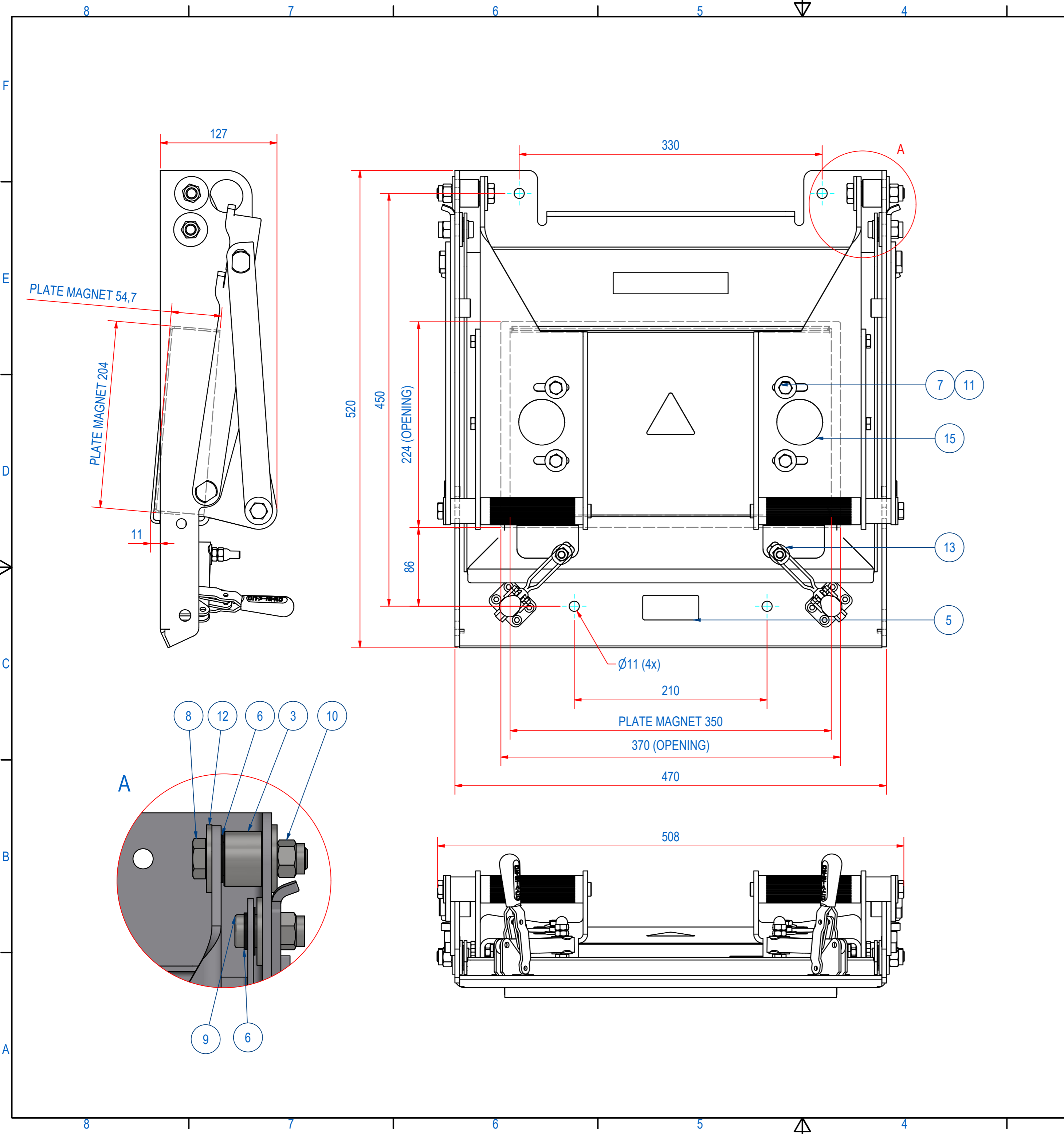

SAFETY BLOCK ADDED ACCORDING TO MODEL E0014813

ITEM	QTY	PART NUMBER	DESCRIPTION	Dimensions
16	1	SVMN020350	SVM-N-204x55-0350-B-F1M	
15	1	E0104276	STICKERS FOR CHUTE SCH	
14	1	E0153532	SCH-S-350 SEAL SILI WHITE	
13	2	1009.00004	COVER PLUG HOLE Ø16.8	
12	8	70.8300012	WASHER 3xd M12x37 - A4	M12x37
11	4	70.8300008	WASHER 3xd M8x24 - A4	M8x24
10	4	60.2300012	NUT, HEX NYLON LOCK M12 - A4	
9	2	51.0312025	SCREW, HEX SH M12x25-A4	M12 x 25
8	2	50.1312055	BOLT, HEX M12x55-A4	M12 x 55
7	4	50.1308016	BOLT, HEX M8x16-A4	M8 x 16
6	4	15.0001820	BEARING IGLIDUR GFM-1820-06	
5	1	E0084040	SCH CHUTE NO ATEX ETCH	
4	1	E0013165	DOUBLE GRIP CHUTE MAGNET	
3	2	E0013049	BUSH D30xd12xH27.5	
2	1	E0153531	ASSY GROUNDPLATE SCH-350	
1	1	E0153534	SCH-S-350 EXTRACTOR PLATE	

ITEM	QTY	PART NUMBER	DESCRIPTION	Dimensions
RAW MAT.	1			
Quantity		Material Number	Material Description	Length (mm) Width (mm)
Sheet:	A2	Extra info:	General tolerance:	ISO 2768 - mK
Drawn:	TT	Weight (kg):	46	Drawn according:
Date:	30-6-2022			ISO268; ISO1101; ISO2553
Spare part:	False	Source:	MC-C	Status:
Quick search:	SCH-350			Standard
Description:	SCH-M-N-204x55-0350-B-B-B			Customer reference number:
				Document number:
				E0153529
				Doc.Rev:
				A
				Part number:
				E0153529
				Rev:
				A



© All rights reserved. Reproduction is not permitted without written permission of GOUDSMIT Magnetic Systems BV