

REV	DATE	BY	DESCRIPTION
-	2-2-2023	AvD	REFERENCE DRAWING SCRB2020012

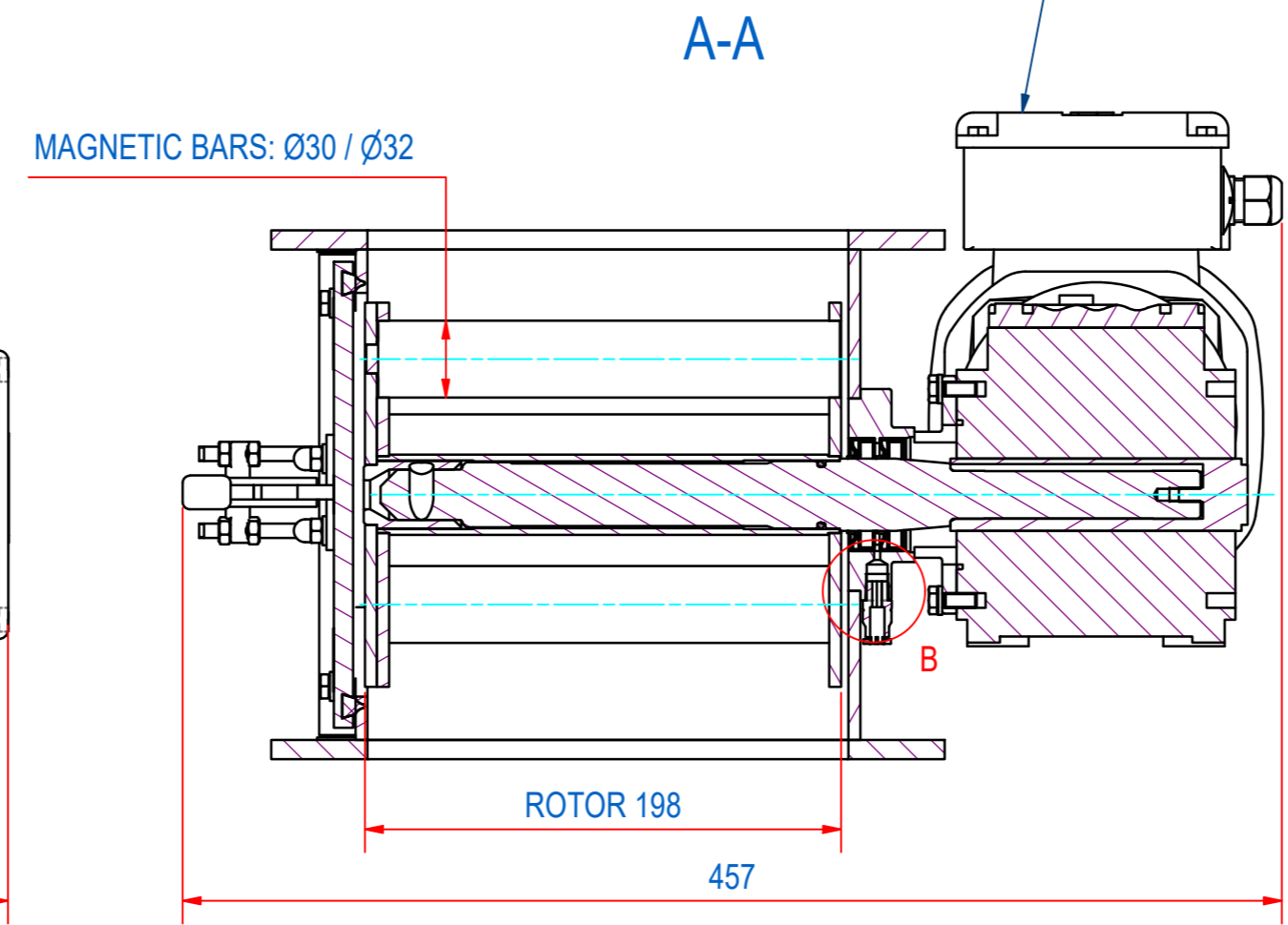
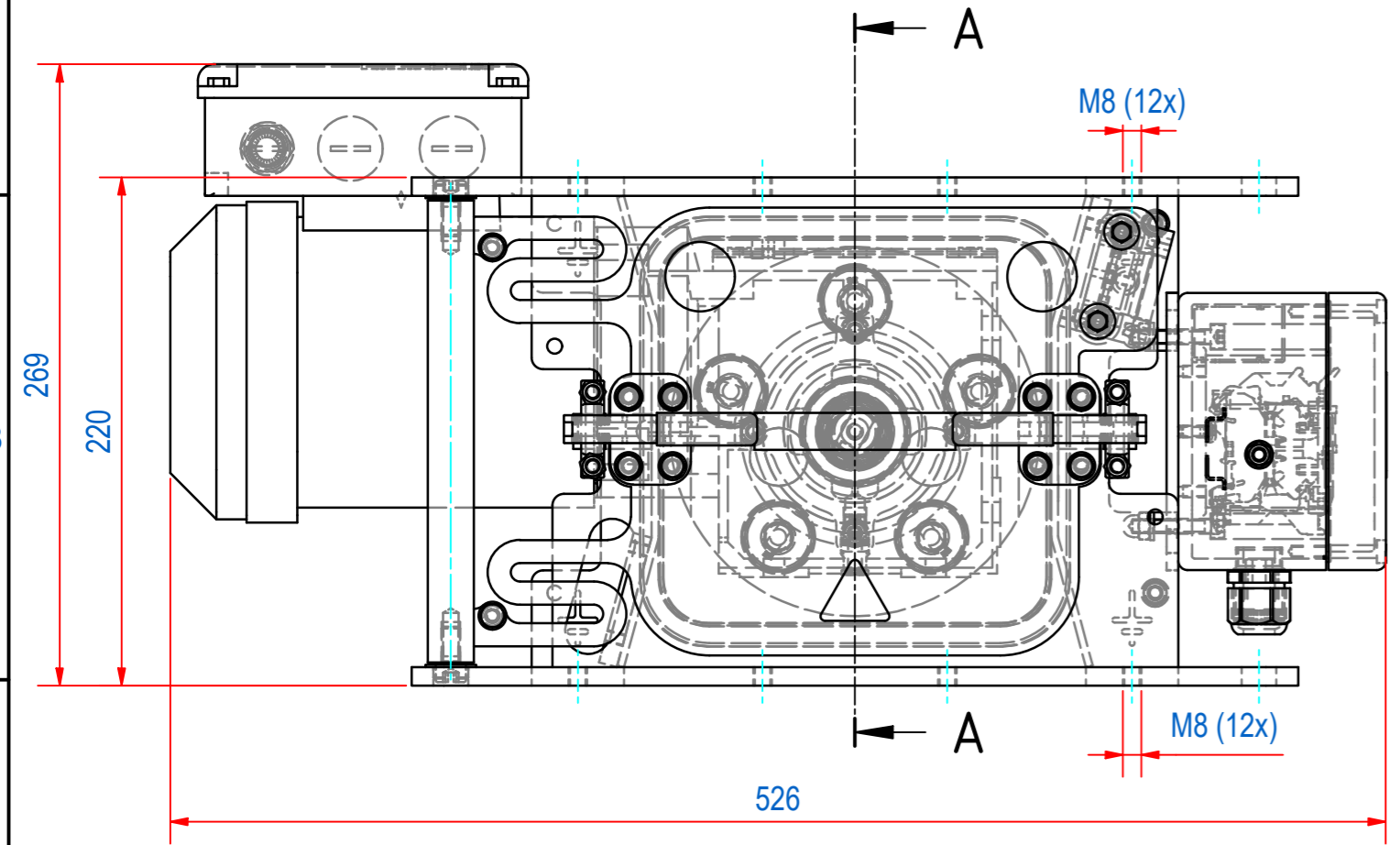
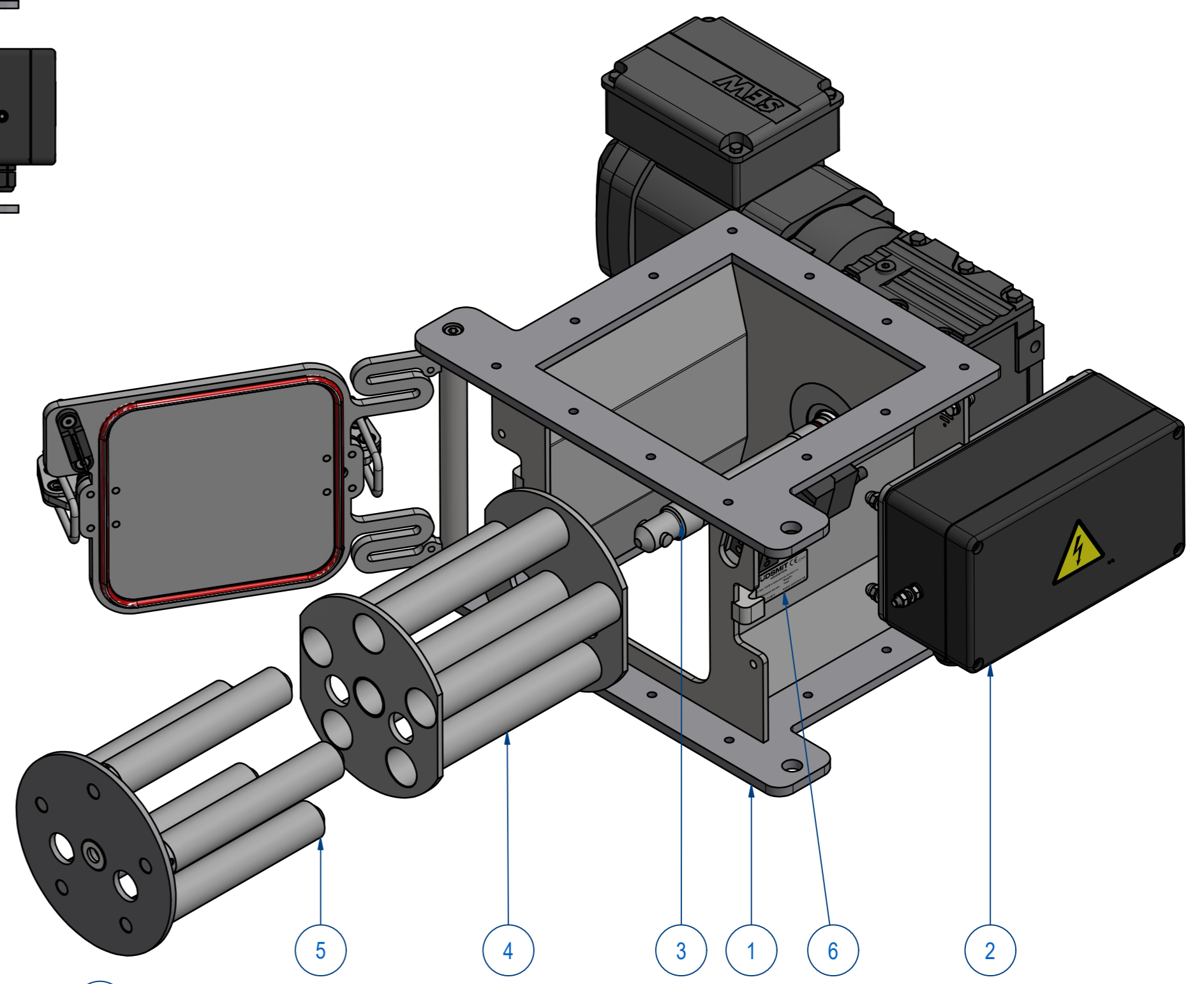
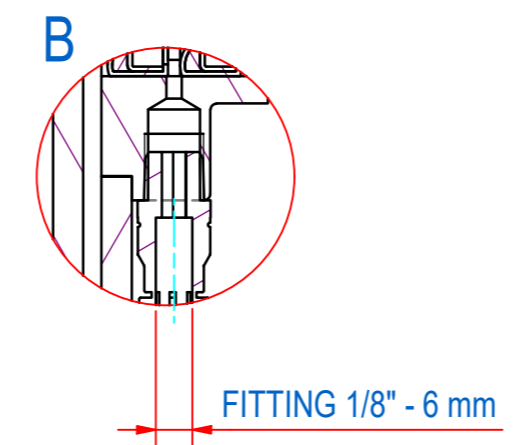
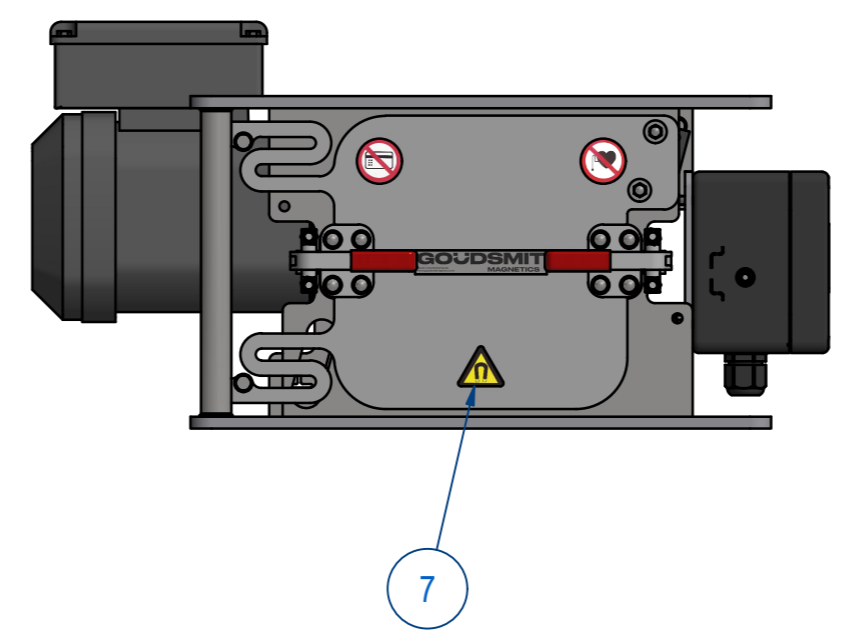
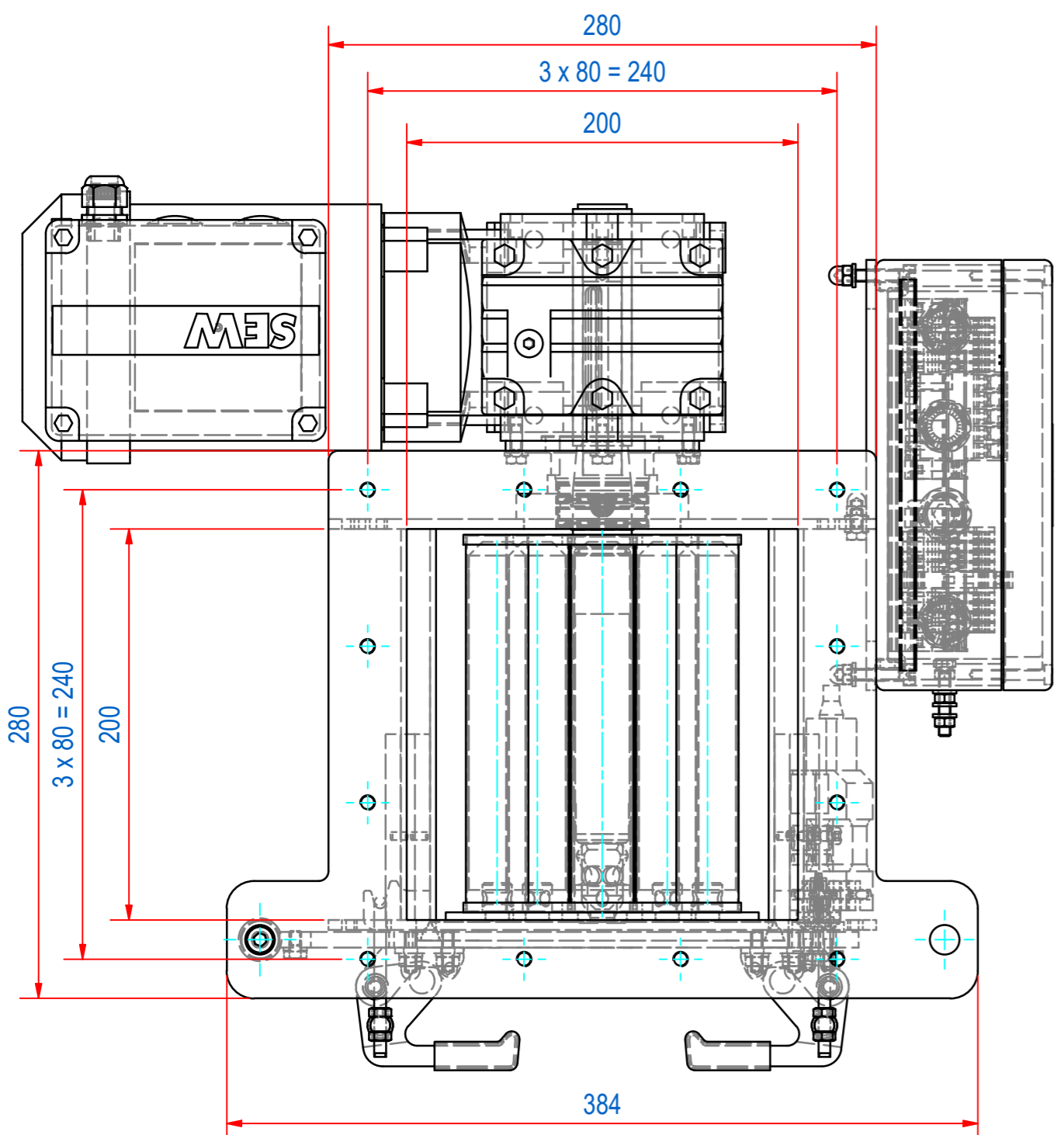

THIS DRAWING CORRESPONDS WITH
ATEX SCHEDULE DRAWING **M53674**

ITEM	QTY	PART NUMBER	DESCRIPTION	Dimensions	
8	1	MO03704202	WA30/II2GD EDNR71M4/2GD/KCC/AL 42RPM		
7	1	E0090295	STICKERS FOR SCRA/SCRB 2020		
6	1	E0090155	TYPE PLATE SECR II 1/2D c T140°C		
5	1	E0153205	SECR-S-2020-05C-HT MAGN PLATE		
4	1	E0152618	SECR-S-2020-05C-B EXTRACTOR		
3	1	A240072	SECR-S-2020-05C-B SHAFT		
2	1	A240059	TERMINAL BOX MOUNT ASSY		
1	1	A240371	HOUSING + DOOR CR2020		
RAW MAT.	Quantity	Material Number	Material Description	Length (mm)	Width (mm)
	1				
Sheet: A2		Extra info: <i>Cleanflow magnet rotating</i>		General tolerance: ISO 2768 - mK	
Drawn: AvD		Weight (kg): 37		Drawn according: ISO268; ISO1101; ISO2553	
Date: 2-2-2023		Source: False		Status: Released	
Spare part: False		Quick search: CR2020		Customer reference number:	
Description: SECR-B-2020-05C-HT-Ex-F5m-B-B-M1-SR-B		© All rights reserved. Reproduction is not permitted without written permission of GOUDSMIT Magnetic Systems BV		Document number: E0157610 Doc.Rev:	
				Part number: E0157610 Rev:	