

REV	DATE	BY	DESCRIPTION
-	21-6-2023	LH	REFERENCE DRAWING SCRB5230012

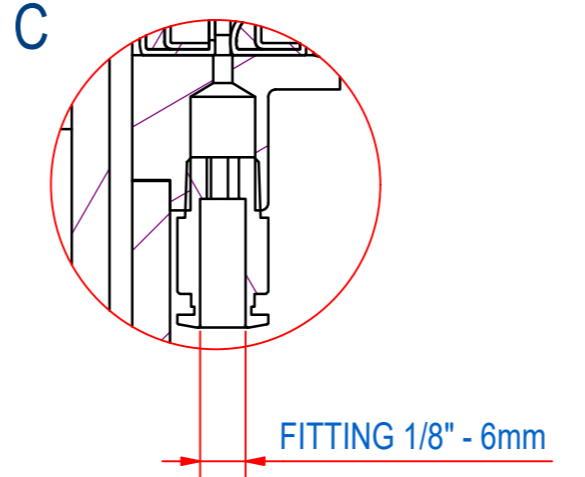
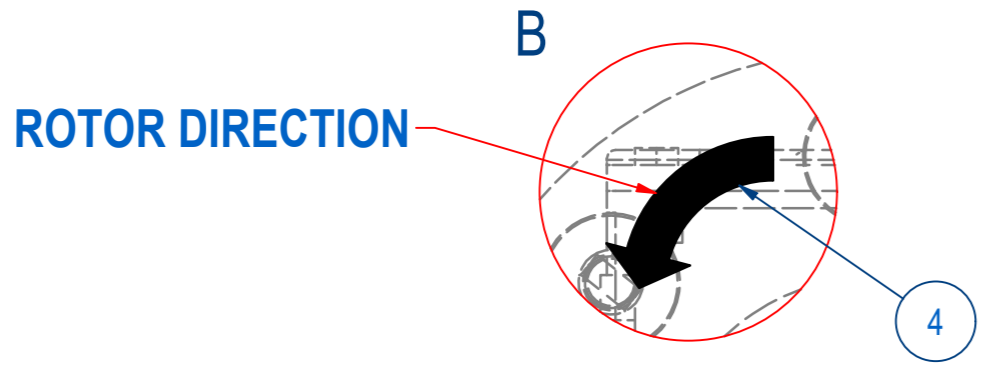
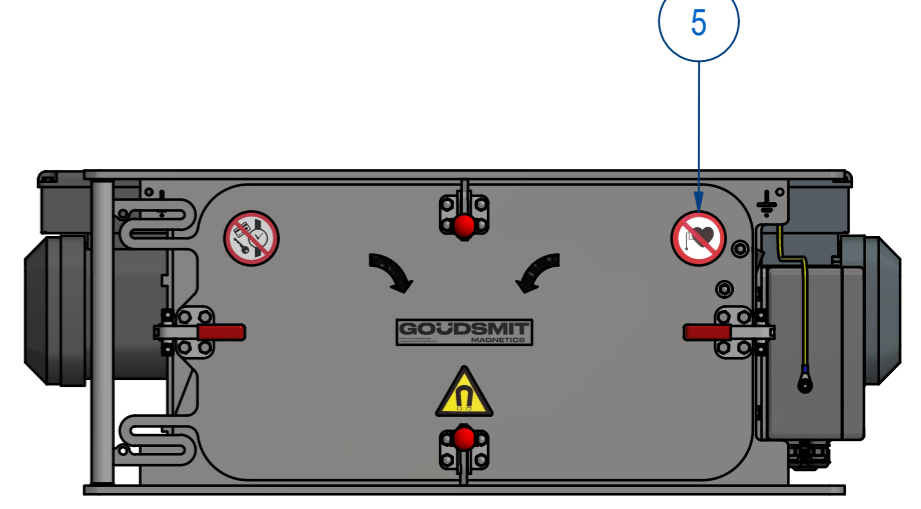
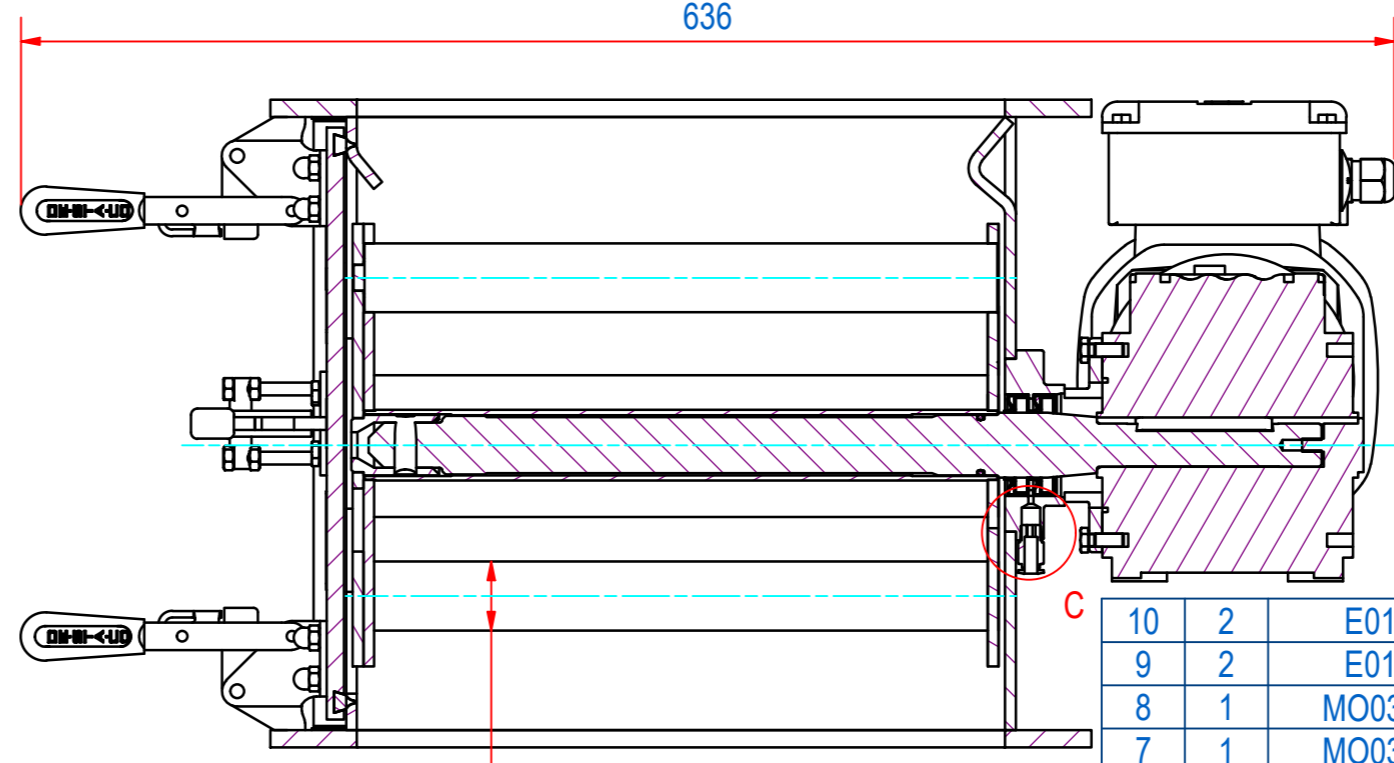
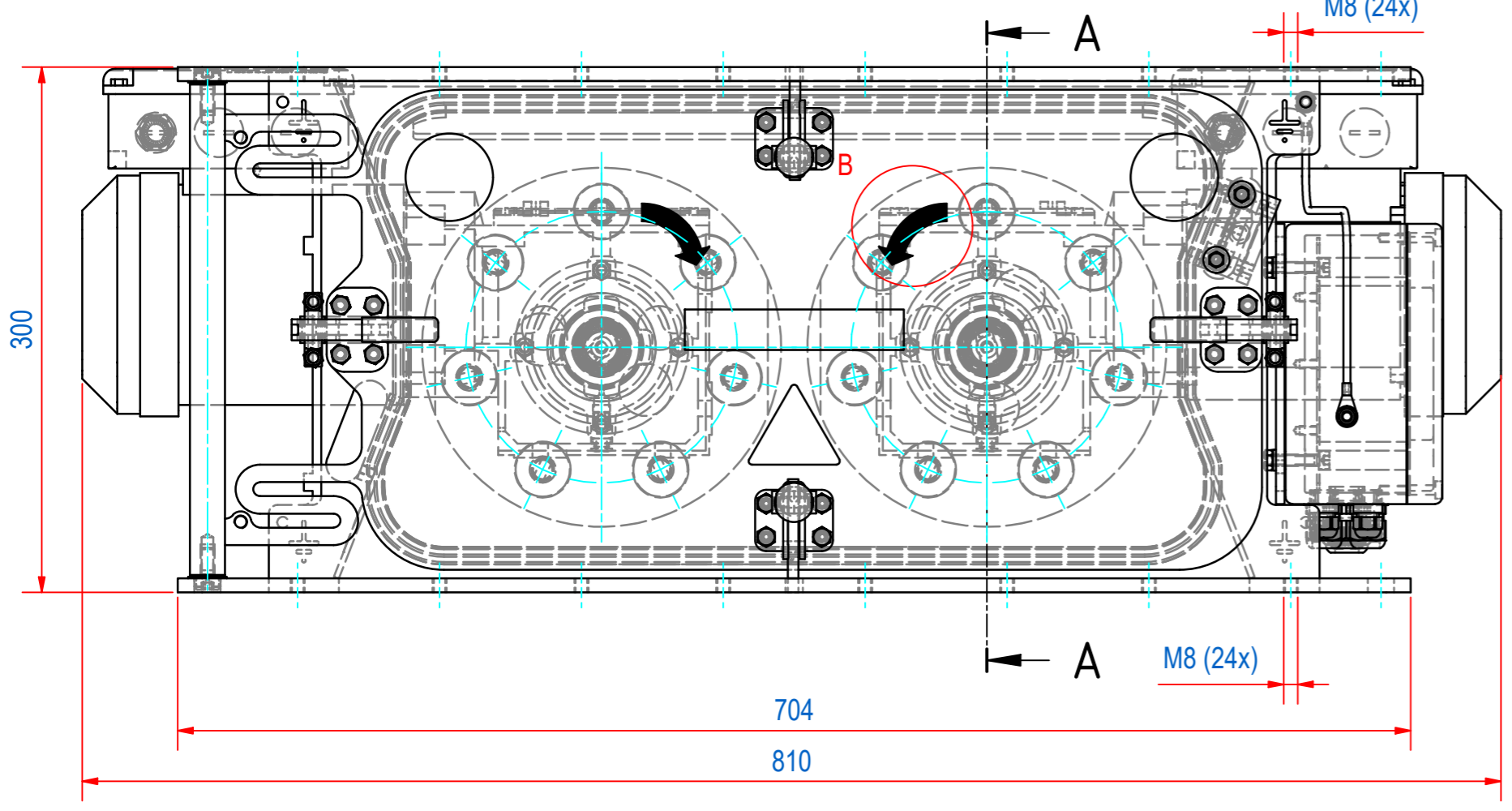
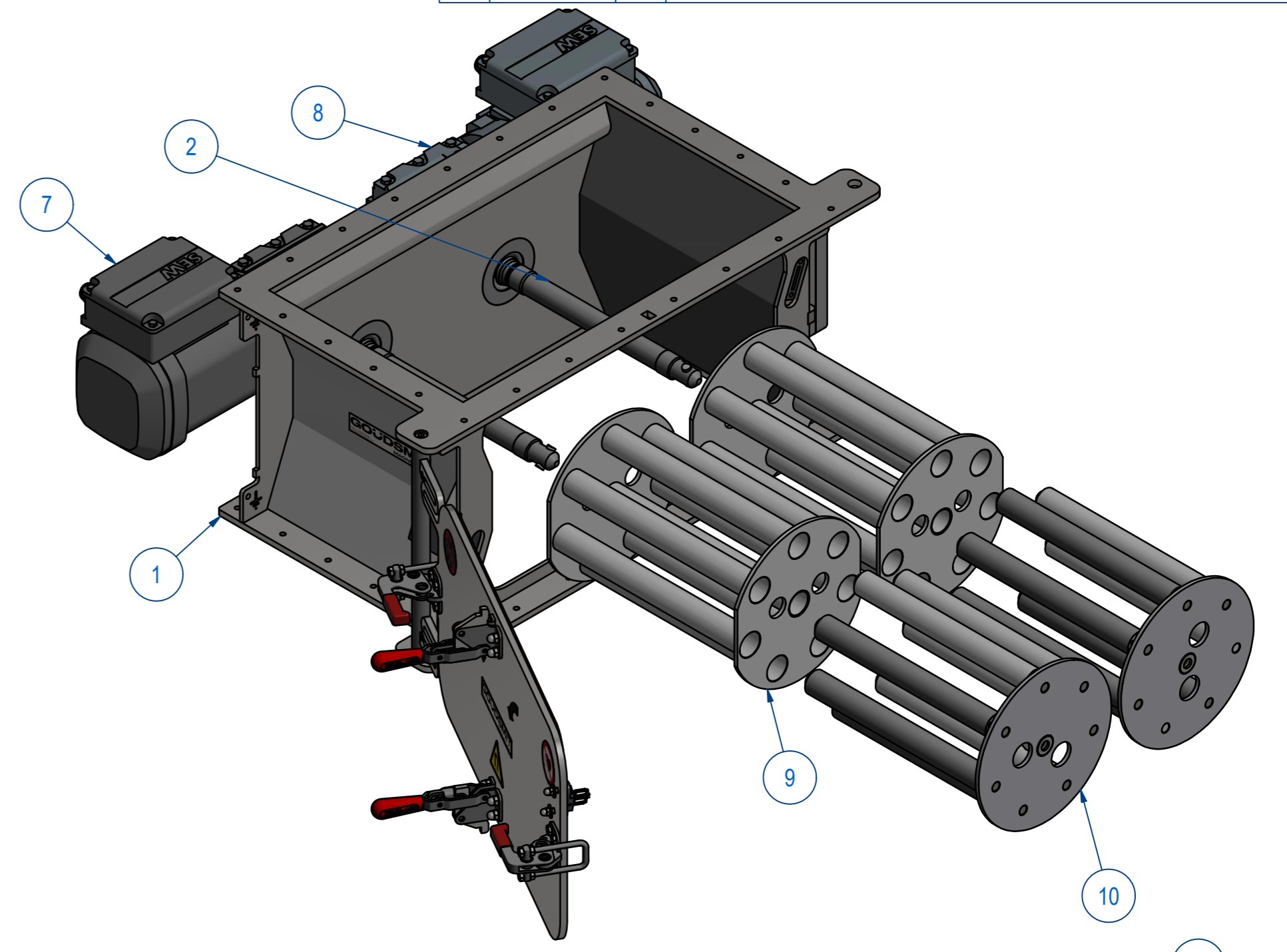
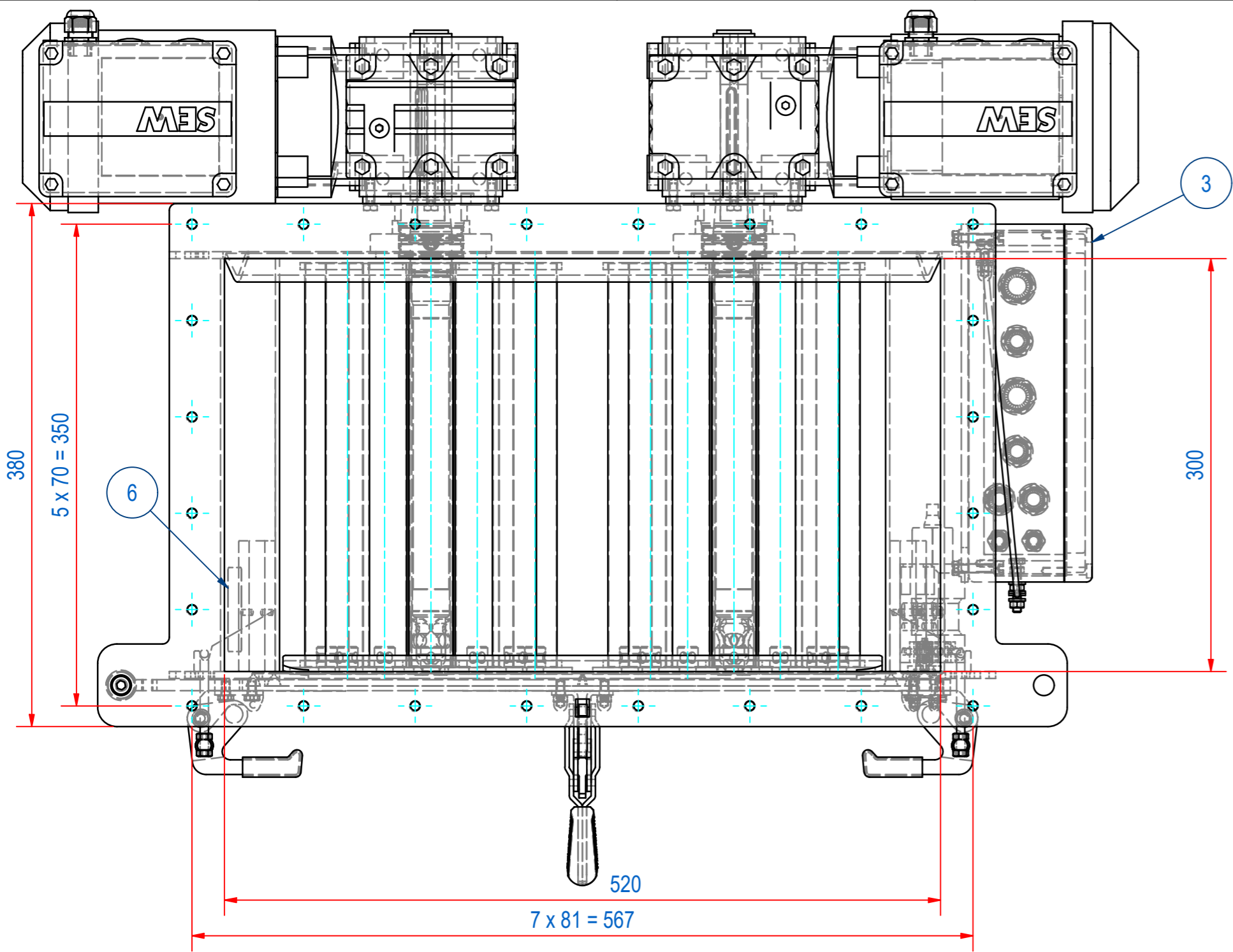

ITEM	QTY	PART NUMBER	DESCRIPTION	Dimensions
10	2	E0153215	SECR-S-3030-07C-HT MAGN PLATE	
9	2	E0152633	SECR-S-3030-07C-B EXTRACTOR	
8	1	MO03704222	WA30/II2GD EDRN71M4/2GD/KCC/AL 43RPM	
7	1	MO03704202	WA30/II2GD EDRN71M4/2GD/KCC/AL 42RPM	
6	1	E0090155	TYPE PLATE SECR II 1/2D c T140°C	
5	1	E0090159	SECR-000-STICKERS AND ETCHING	
4	2	E0060897	TURNING DIRECTION CR5320	
3	1	A240198	TERMINAL BOX TWIN ROTOR ASSY	
2	2	A240060	SECR-S-3030 SHAFT	
1	1	A240187	HOUSING + DOOR CR520x300	

RAW MAT.	Quantity	Material Number	Material Description	Length (mm)	Width (mm)
1	1				

Sheet: A2 Drawn: LH Date: 21-6-2023 Spare part: False Quick search: CR5230	Extra info: Cleaning magnet rotating Manual cleaning GOUDSMIT MAGNETICS <small>© All rights reserved. Reproduction is not permitted without written permission of GOUDSMIT Magnetic Systems BV</small>	General tolerance: ISO 2768 - mK Drawn according: ISO286; ISO1101; ISO2553 Status: Released Customer reference number: Document number: E0159986 Part number: E0159986
---	---	--