

REV	DATE	BY	DESCRIPTION
-	8-8-2023	CR	REFERENCE DRAWING SCRC0150012

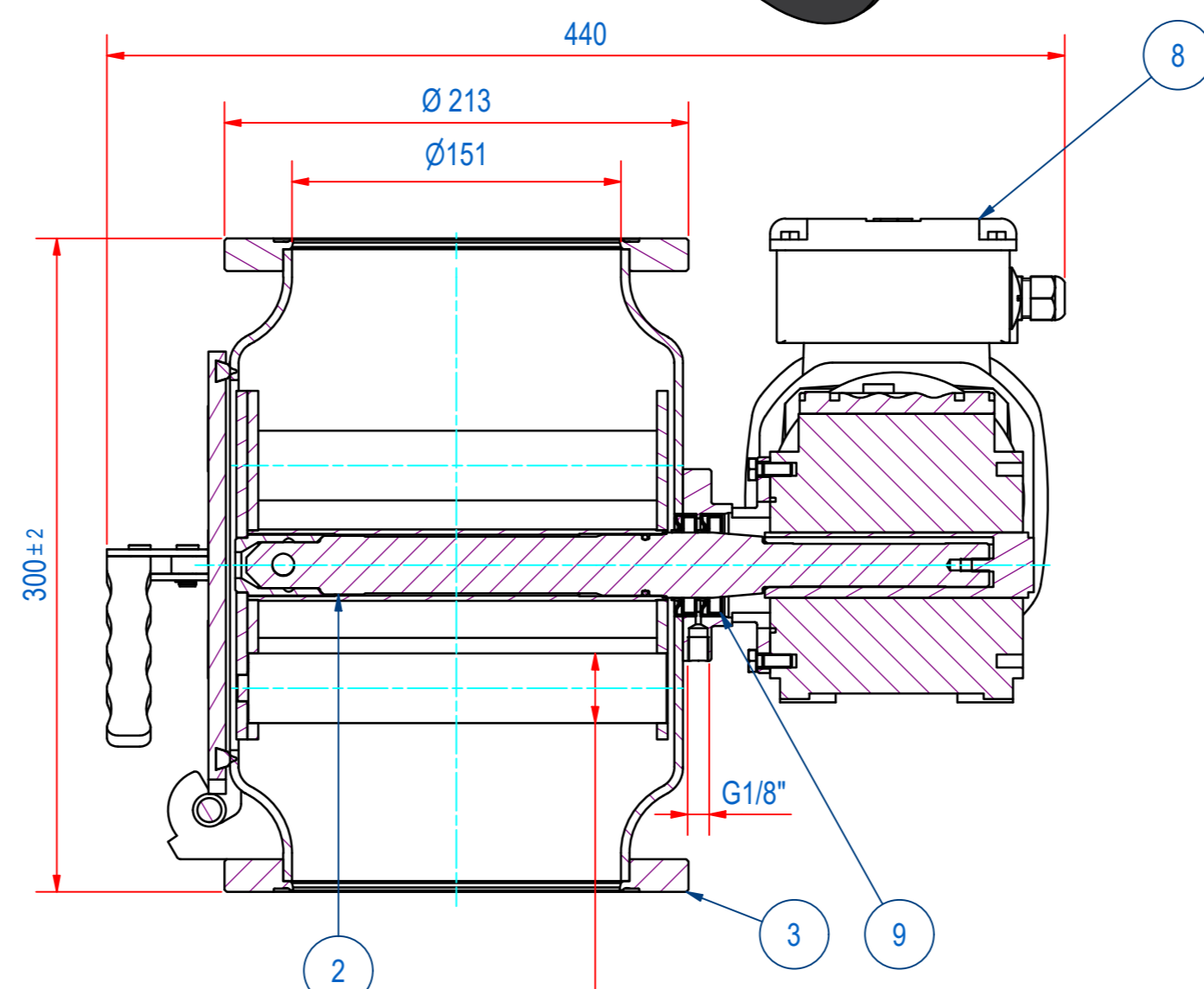
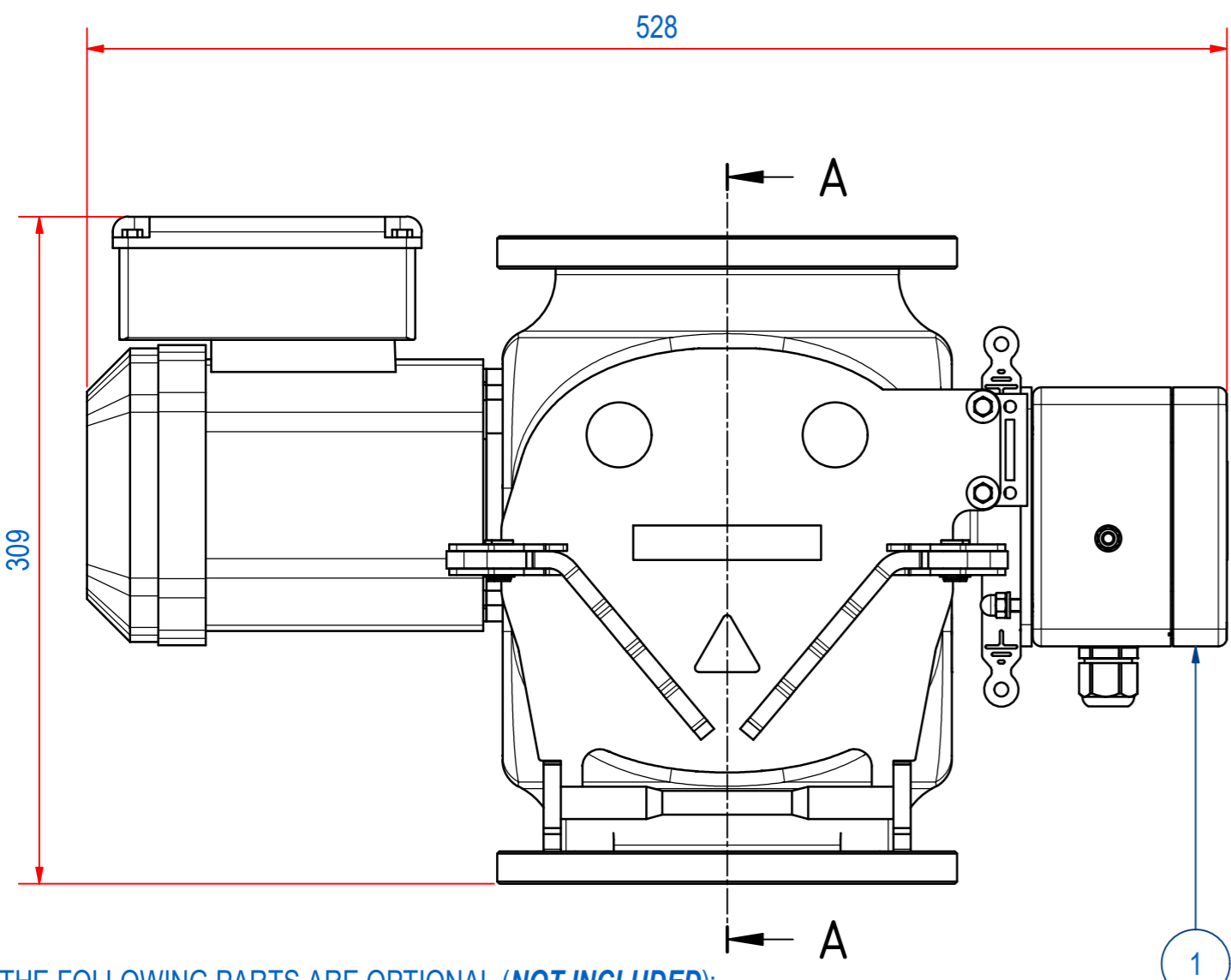
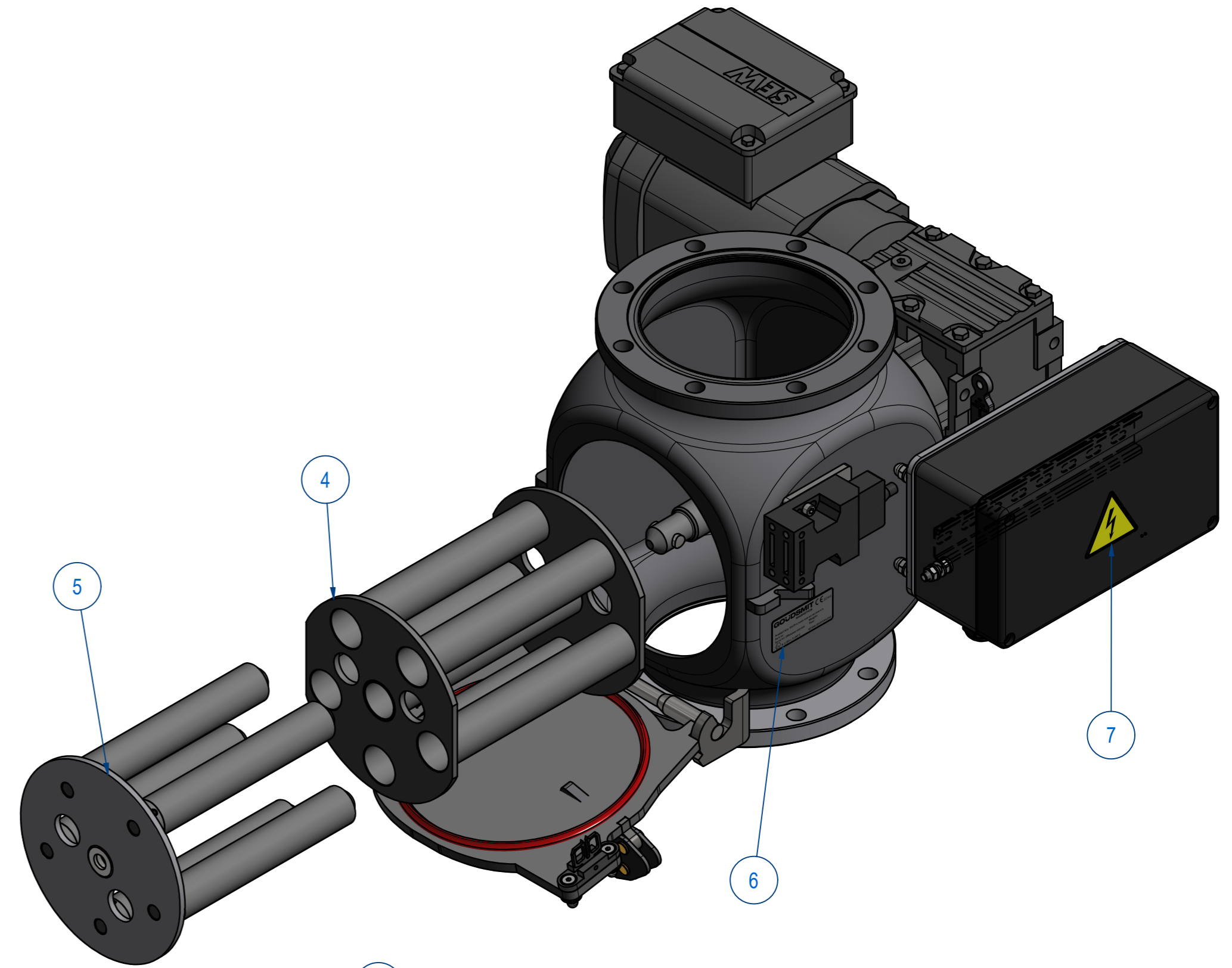
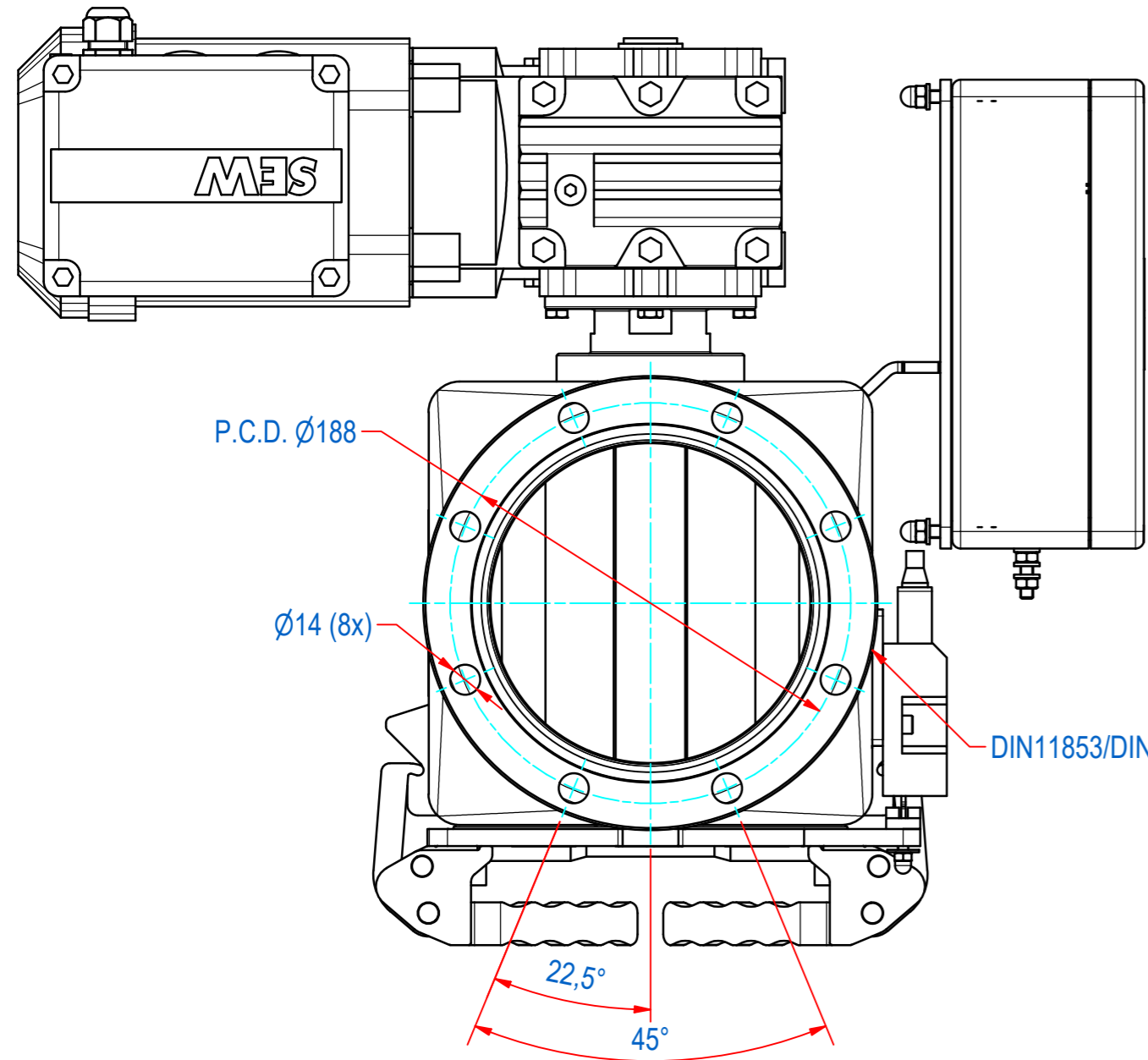

THIS DRAWING CORRESPONDS WITH
ATEX SCHEDULE DRAWING **M53674**

ITEM	QTY	PART NUMBER	DESCRIPTION	Dimensions
9	2	74.2000054	SECR-S PS SEAL 30x47x10 EC1935	
8	1	MO03704202	WA30/II2GD EDNR71M4/2GD/KCC/AL 42RPM	
7	1	E0090295	STICKERS FOR SCRA/SCRB 2020	
6	1	E0090155	TYPE PLATE SECR II 1/2D c T140°C	
5	1	E0153205	SECR-S-2020-05C-HT MAGN PLATE	
4	1	E0152618	SECR-S-2020-05C-B EXTRACTOR	
3	1	E0090837	HYDROFORM HOUSE + DOOR CR150	
2	1	A240072	SECR-S-2020 SHAFT	
1	1	A240059	TERMINAL BOX MOUNT ASSY	

RAW MAT.	Quantity	Material Number	Material Description	Length (mm)	Width (mm)
1	1				

Sheet: A2 Drawn: CR Date: 8-8-2023 Spare part: False Quick search: CR150	Extra info: CLEANFLOW MAGNET ROTATING DIN11853/DIN11864 A-2 GOUDSMIT MAGNETICS <small>© All rights reserved. Reproduction is not permitted without written permission of GOUDSMIT Magnetic Systems BV</small>	General tolerance: ISO 2768 - mK Drawn according: ISO286; ISO1101; ISO2553 Status: Released Customer reference number: Document number: E0160840 Part number: E0160840
---	---	---

THE FOLLOWING PARTS ARE OPTIONAL (**NOT INCLUDED**):
77.0320151 - DIN11853/DIN11864 NUT FLANGE DN150
74.0300176 - DIN11853/DIN11864 O-RING 152 x 5 DN150 EPDM