

DOC.NR.	REV	DATE	BY	DESCRIPTION
EDAR306002	C	7-12-2022	GS	PRODUCT KEY ADDED
EDAR306002	D	23-3-2023	DK	SOURCE CODE ADDED, LIFTING TOOL ADDED
EDAR306002	E	27-3-2023	DK	VIEWS UPDATED, PRODUCT KEY CHANGED

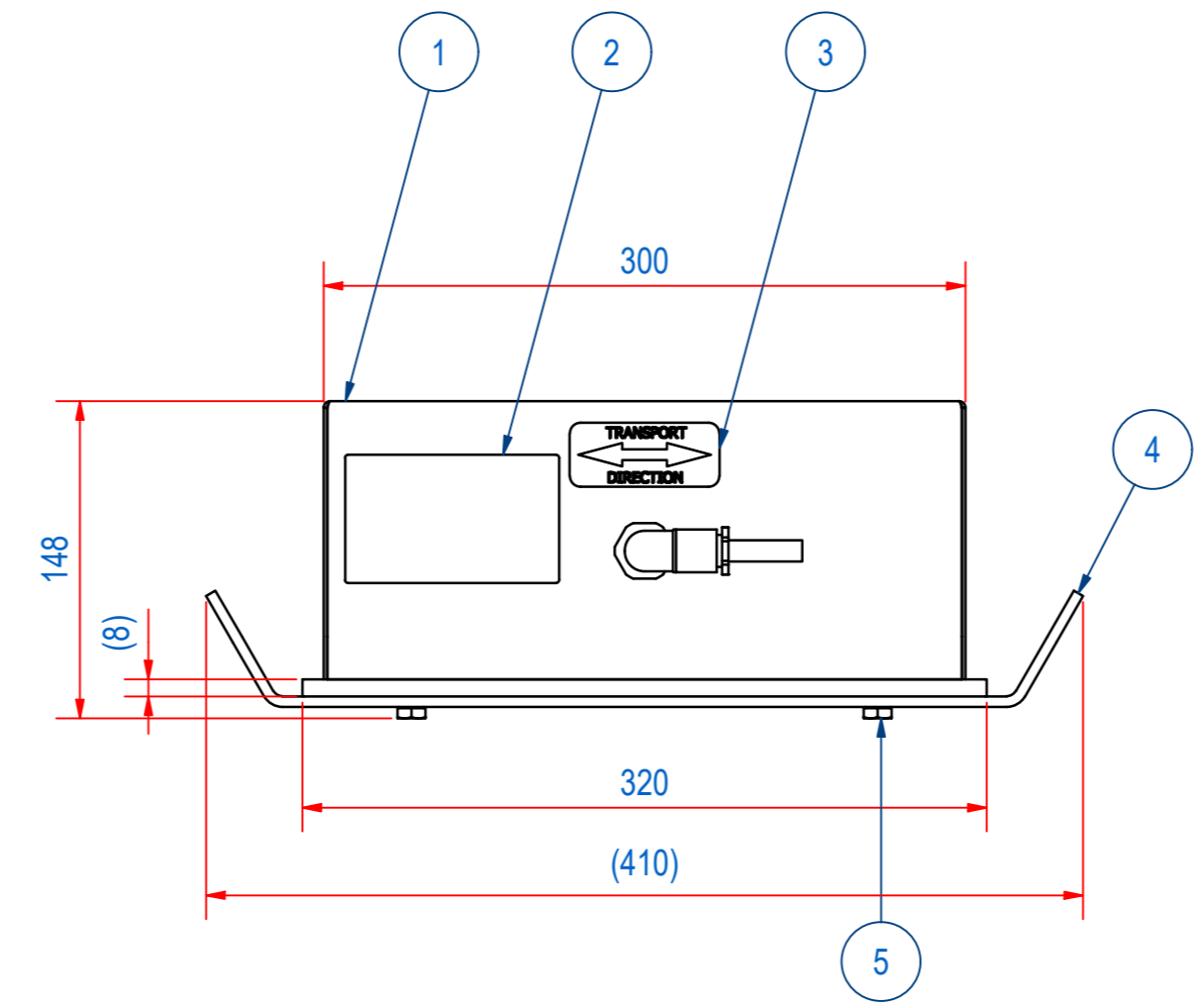
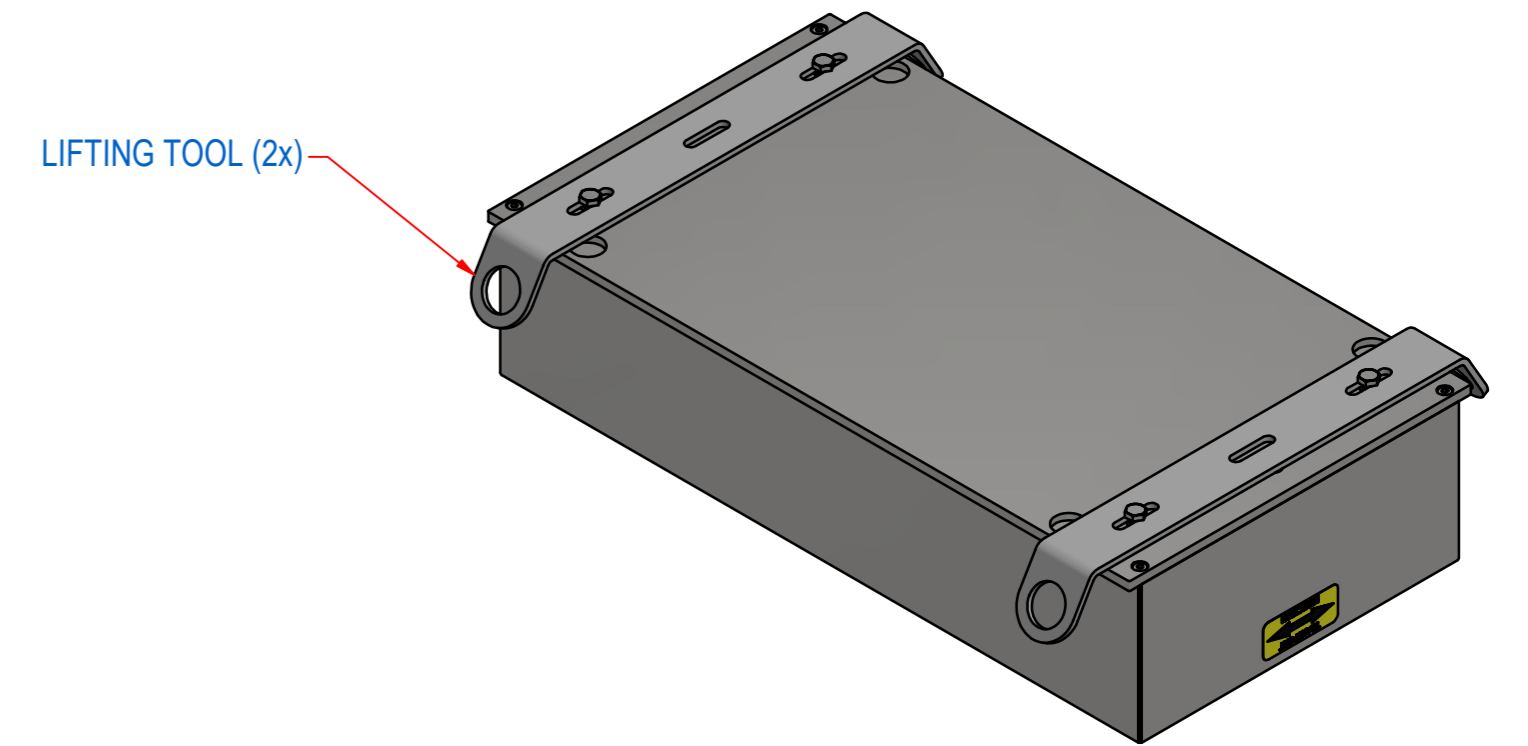
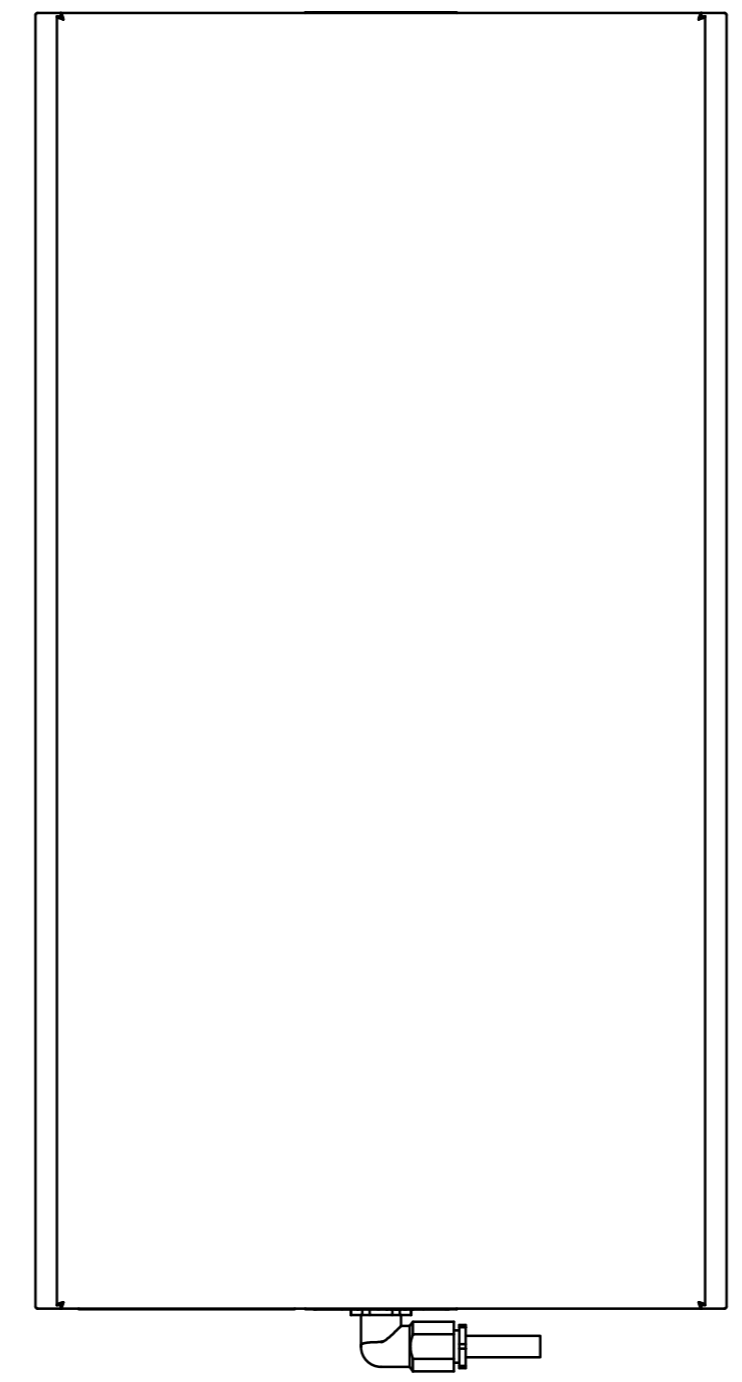
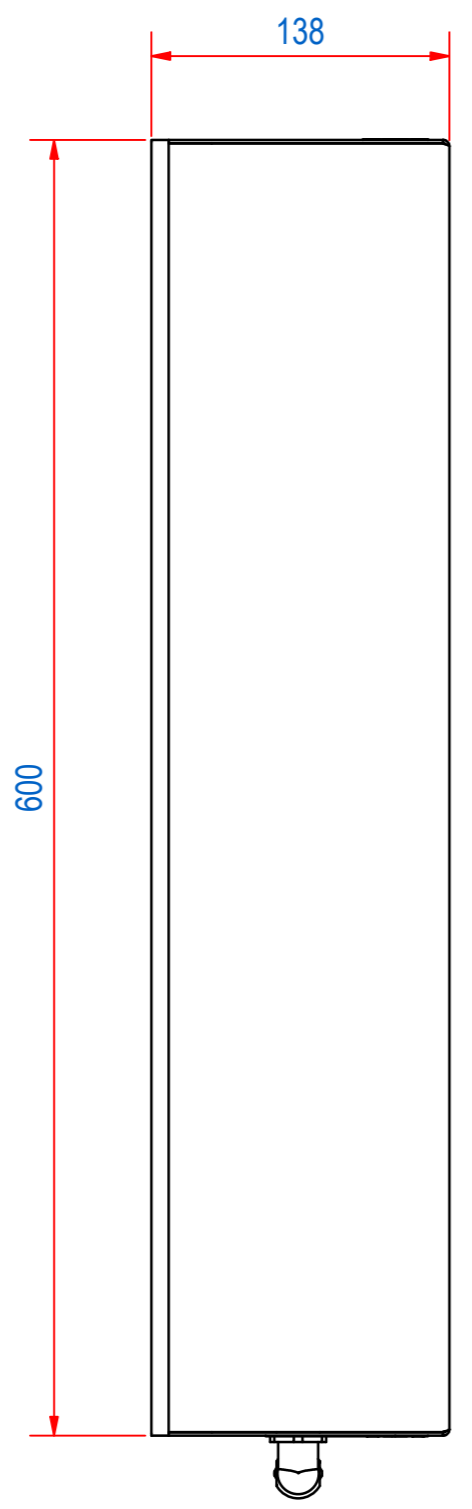
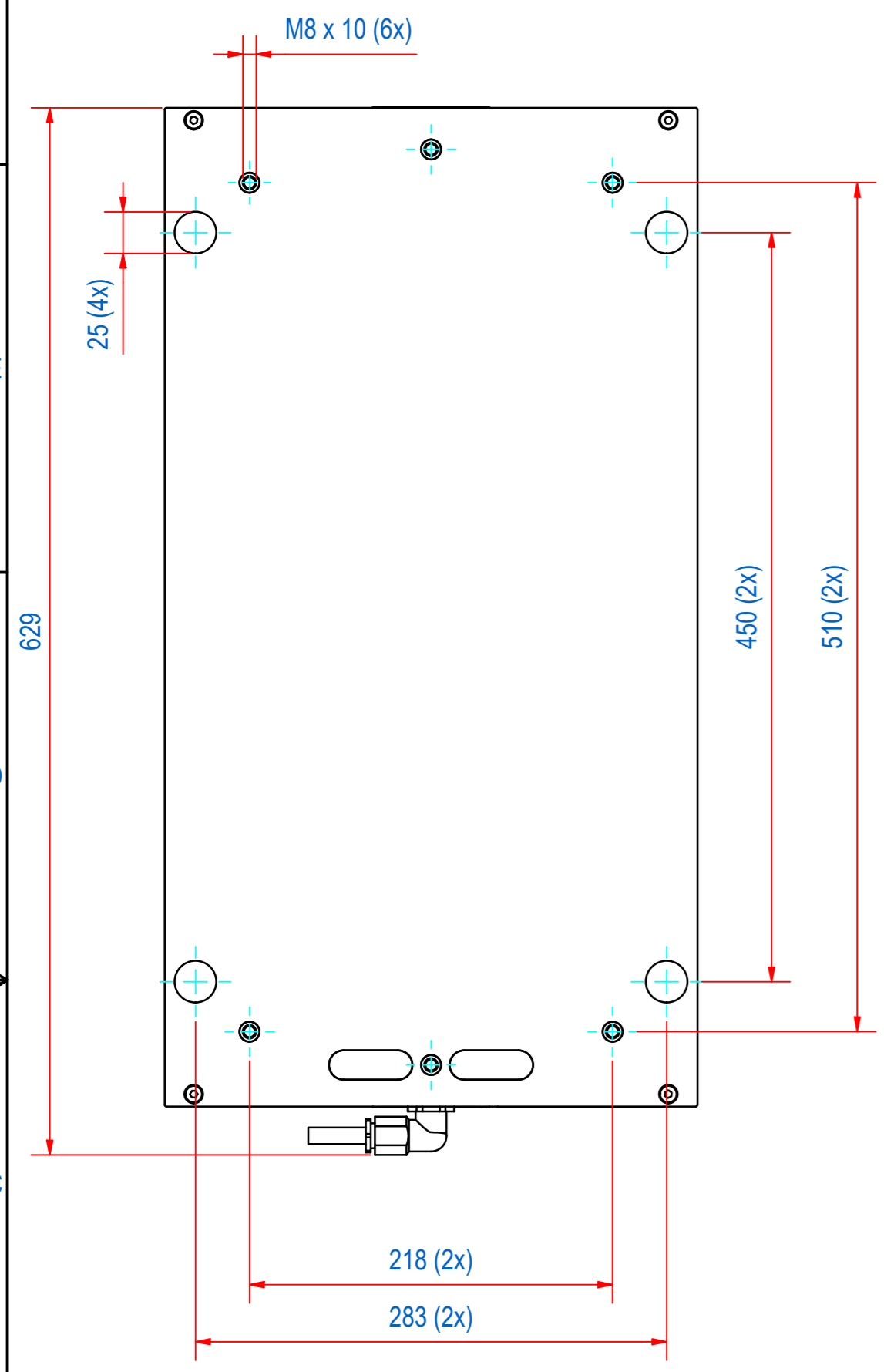

ITEM	QTY	PART NUMBER	DESCRIPTION	Dimensions
5	4	50.1308012	BOLT, HEX M8x12-A4	M8 x 12
4	2	E0158384	HDTA-LIFTING TOOL	
3	2	E0013844	HDTA-STICKER DOUBLE ARROW	
2	1	E0085444	HDTA-STICKER EDAR CSA	
1	1	E0057694	HDTA-FINISHING DRAWING	

RAW MAT.	Quantity	Material Number	Material Description	Length (mm)	Width (mm)
⊕	1				
Sheet:	A2	Extra info:		General tolerance: ISO 2768 - mK	
Drawn:	PB	Weight (kg): 100	60 Hz Cable UL/CSA certified Duty Cycle: 100%	Drawn according to: ISO268; ISO1101; ISO2553	
Date:	14-7-2016	GOUDSMIT MAGNETICS		Status: Standard	
Spare part:	False	Source: MC-C	© All rights reserved. Reproduction is not permitted without written permission of GOUDSMIT Magnetic Systems BV	Customer reference number:	
Quick search:	EDAR6030	Description: HDTA-0600x0300-230V-B		Document number: EDAR306002	Doc.Rev: E
				Part number: EDAR306002	Rev: E