

DOC.NR.	REV	DATE	BY	DESCRIPTION
	-	31-7-2013	PB	NEW VAULT, NEW REVISION. NOTHING CHANGED. OLD REV WAS A
EHKAC10000	A	13-2-2024	PB	THICKNESS 50 +0/-1 WAS 50±0.2

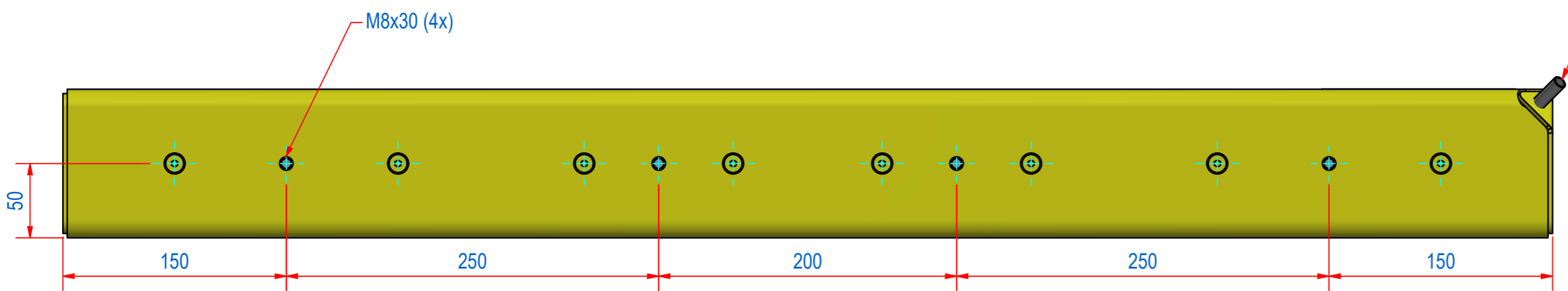

CABLE VMVL 2x1,5 L=5000
NOT SHOWN

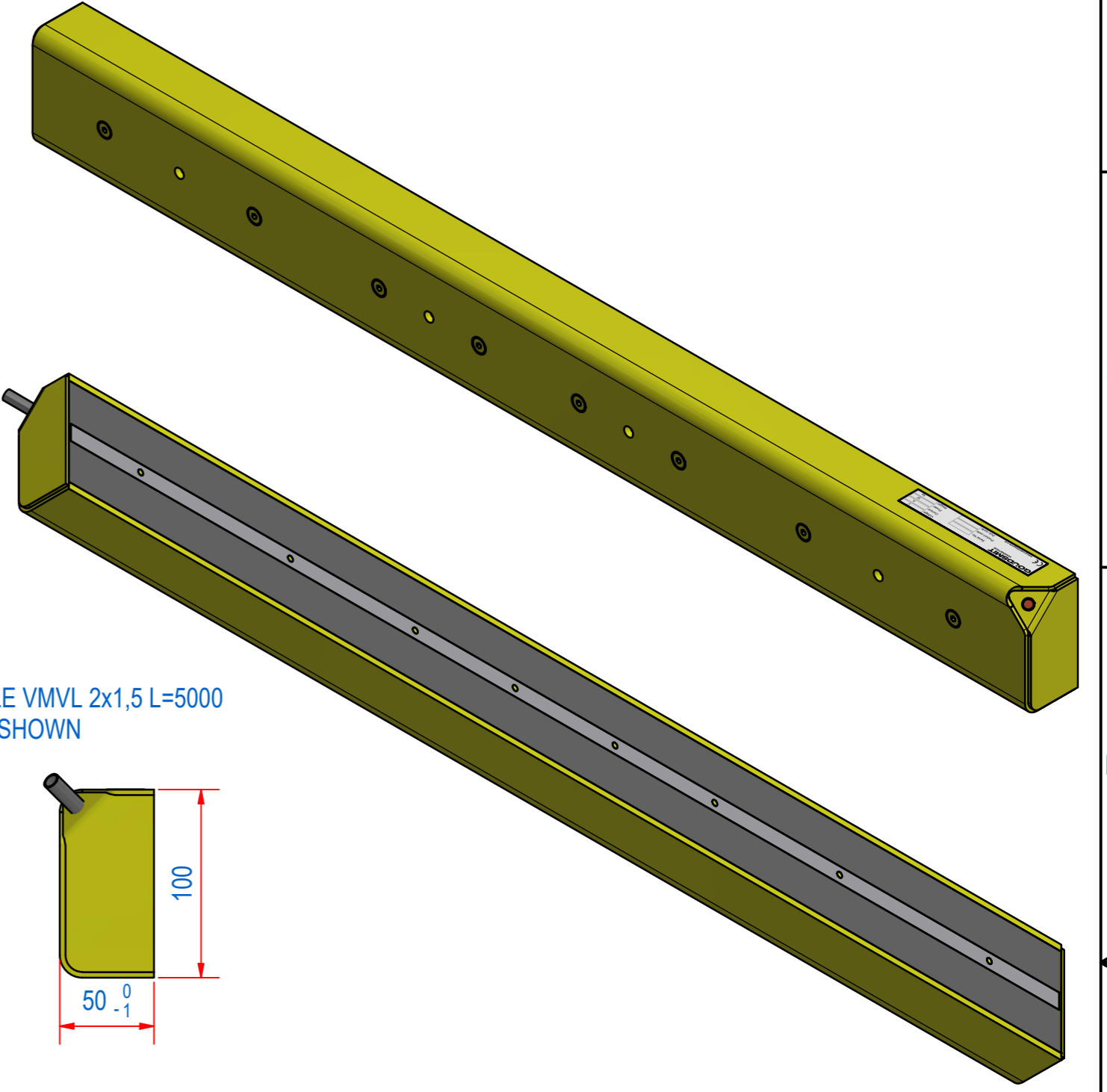
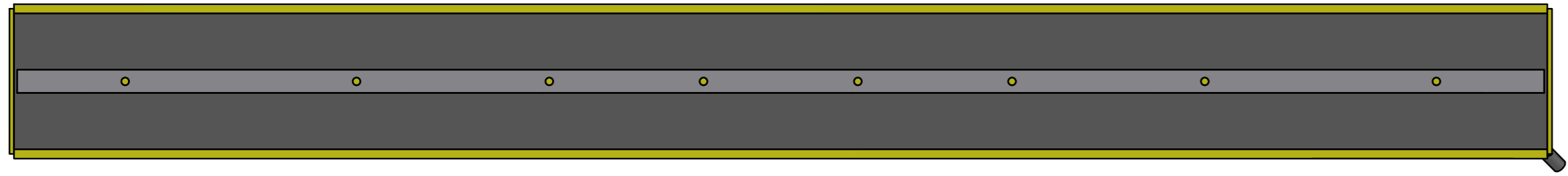
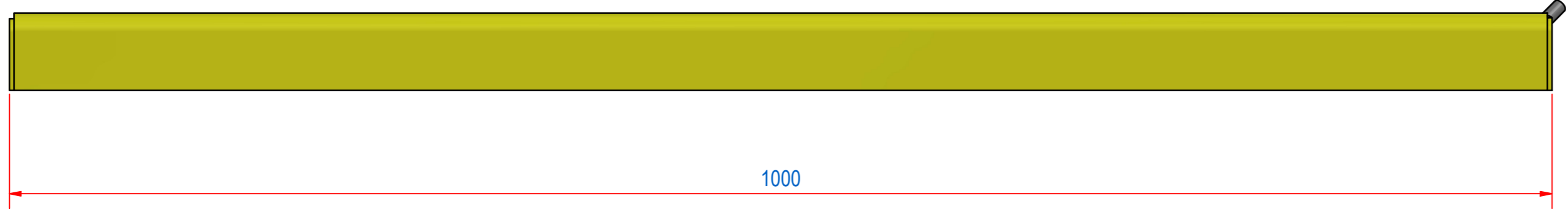
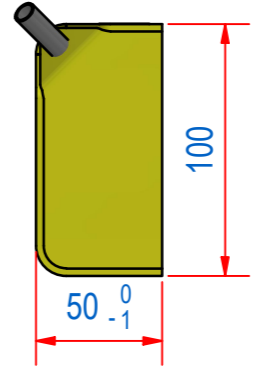

ITEM	QTY	PART NUMBER	DESCRIPTION	Dimensions
2	1	M59957	HEB-STICKER ELECTRO ROD	
1	1	M69721	HEB-ELECTRO ROD ASSY C L=1000	
RAW MAT.	1			Length (mm) Width (mm)
Quantity		Material Number	Material Description	General tolerance: <i>ISO 2768- mK</i>
Sheet: <i>A2</i>		Extra info:		Drawn according: <i>ISO286; ISO1101; ISO2553</i>
Drawn: <i>PB</i>		Weight (kg): <i>16</i>		Status: <i>Standard</i>
Date: <i>31-7-2013</i>				Customer reference number:
Spare part: <i>False</i>				Document number: <i>EHKAC10000</i>
Quick search: <i>EHKA1000</i>		© All rights reserved. Reproduction is not permitted without written permission of GOUDSMIT Magnetic Systems BV		Part number: <i>EHKAC10000</i>
Description: <i>HEB-100x50-1000-GC</i>				Rev: <i>A</i>