

## User Manual

### Magnetic grid, series SMR

**Suitable for removing ferromagnetic (such as ferrous) particles from powders. Not suitable for poorly flowing products and/or environments.**

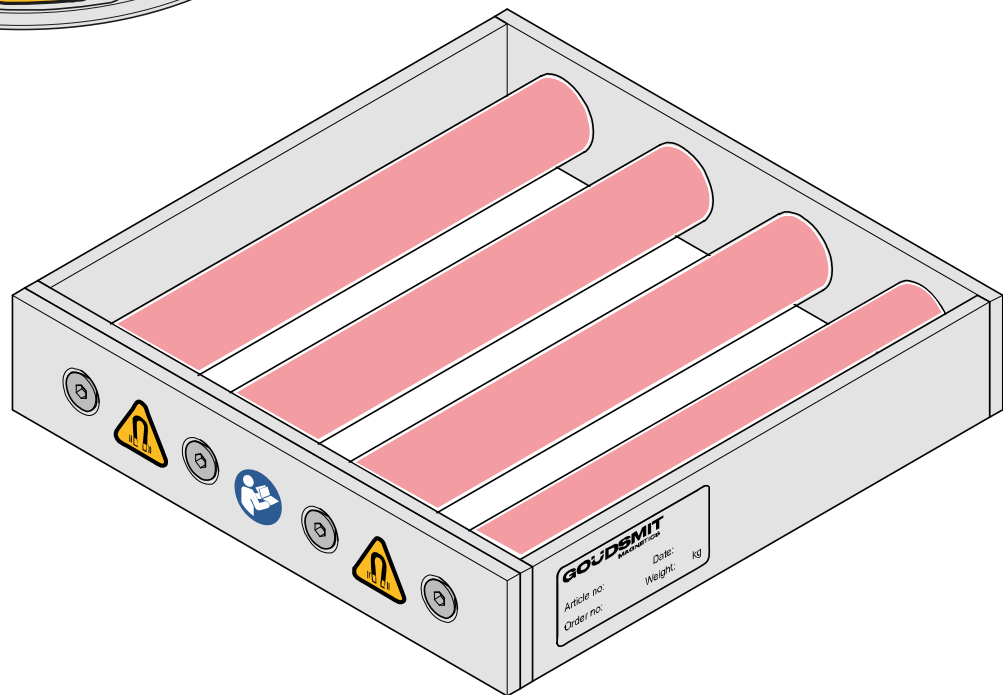
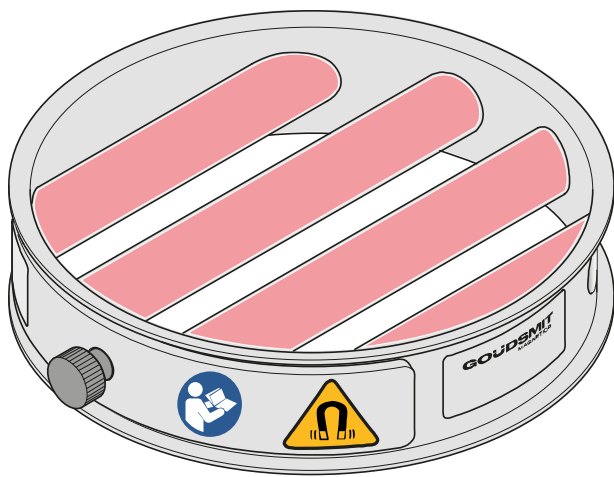

© Copyright. All rights reserved.

## Table of contents

<b>1 Introduction</b> .....	<b>4</b>
<b>2 Safety</b> .....	<b>5</b>
2.1 Safety .....	5
2.2 General safety instructions.....	5
2.3 Damage due to magnetic field .....	5
2.4 Other remarks/warnings.....	5
<b>3 Standards and regulations</b> .....	<b>6</b>
3.1 Limit values for occupational and public exposure to permanent magnetic and electromagnetic fields.....	6
<b>4 Specifications</b> .....	<b>7</b>
4.1 Range of application .....	7
4.2 Description of function.....	7
4.3 Structure and materials information .....	7
4.4 Use in food product flows.....	7
4.5 Models available – specials .....	7
4.6 Temperatures .....	8
4.7 Free space .....	8
4.8 ATEX (if applicable) .....	8
<b>5 Product information</b> .....	<b>9</b>
5.1 Overview drawing.....	9
5.2 Scope of delivery.....	9
5.3 Identification plate .....	9
<b>6 Transport and installation</b> .....	<b>10</b>
6.1 Transport.....	10
6.2 Installation .....	10
<b>7 Operating principle</b> .....	<b>12</b>
7.1 General .....	12
7.2 Cleaning process – removal of ferromagnetic particles .....	12
<b>8 Maintenance and inspection</b> .....	<b>14</b>
8.1 General guidelines .....	14
8.2 Frequency of maintenance.....	14
8.3 Cleaning instructions.....	14
8.4 Flux density measurement of the magnetic bars .....	15
<b>9 Troubleshooting</b> .....	<b>16</b>
9.1 Troubleshooting table.....	16
<b>10 Service, storage and disassembly</b> .....	<b>17</b>
10.1 Customer service .....	17
10.2 Spare parts.....	17
10.3 Storage and disposal .....	17

## 1 Introduction

This manual contains information about correct use and maintenance of the device. The manual contains instructions that should be followed to prevent injury and serious damage and to ensure safe and problem-free operation of the device. Read this manual thoroughly and ensure that you fully understand everything before using the device.

If you need more information or still have questions, please contact Goudsmit Magnetic Systems B.V.. The contact details are provided on the title page of this manual. Additional copies of the manual can be ordered by providing the device description and/or article number as well as the order number.

The descriptions and figures in this manual, provided for explanatory purposes, may differ from the descriptions and figures of your version.

In this manual, the SMR magnetic grid magnetic grid is further referred to as “device”.



### NOTICE

**Read this manual carefully before installation and commissioning!**



### NOTICE

This manual and manufacturer's declaration(s) are to be considered part of the device.

Both documents must remain with this device if it is sold.

The manual must be available to all operating personnel, service technicians and others who work with the device throughout the life of the device.

## 2 Safety

### 2.1 Safety

This chapter describes the safety risks of the device. Where necessary, warning pictograms have been affixed to the device. These pictograms are explained later in this document.



#### NOTICE

Know your pictograms:

- ▶ Read the warning pictograms on the device carefully.
- ▶ Check that the pictograms on the device are present and legible at regular intervals.
- ▶ Keep the pictograms clean.
- ▶ Replace pictograms that have become illegible or that have been removed with new pictograms in the same locations.

### 2.2 General safety instructions

- The instructions in this manual must be complied with. If they are not, there is a risk of material damage, personal injury and even a danger of death.
- The device may only be used to filter powders and granulates. Any other use is inconsistent with the regulations. Any resulting damage is not covered by the factory warranty.
- Ensure that people who work on the device or in its immediate vicinity wear adequate protective equipment.
- Impose additional safety measures and use additional warning pictograms if the device remains easily accessible to people. If this isn't possible, ensure that clear instructions are provided for the entire system in which this device is integrated.
- Work on the device may only be carried out by qualified personnel. Ideally, maintenance work on the magnets should be carried out by Goudsmit Magnetismics personnel.
- Always take locally applicable safety and environmental regulations into account.

### 2.3 Damage due to magnetic field

The devices generate a powerful magnetic field that attracts ferromagnetic particles. This also applies to ferrous materials that may be carried on the person, including keys, coins and tools. When working within the magnetic field, use non-ferromagnetic tools and workbenches with a wooden worktop and non-ferromagnetic base.



#### WARNING

##### Strong magnetic field

There is a risk of personal injury when carrying out work and measurement checks on the device. Do not place the fingers or other body parts between the device and your structure.

### 2.4 Other remarks/warnings

Rectify all faults before operating the device. If the device is used whilst exhibiting a fault, after having completed a risk assessment, warn operating and maintenance personnel of the fault and the potential risks associated with that fault.

## 3 Standards and regulations

### 3.1 Limit values for occupational and public exposure to permanent magnetic and electromagnetic fields

The limit values and magnetic fields are defined in accordance with the EMC Directive 2013/35/EU as follows: Directive 2013/35/EU of the European Parliament and of the Council of 26 June 2013 on the minimum health and safety requirements regarding the exposure of workers to the risks arising from physical agents (electromagnetic fields).

Observe the following measures in relation to exposure to magnetic fields in accordance with EN12198-1 (machine category = 0, no restrictions) of the device:

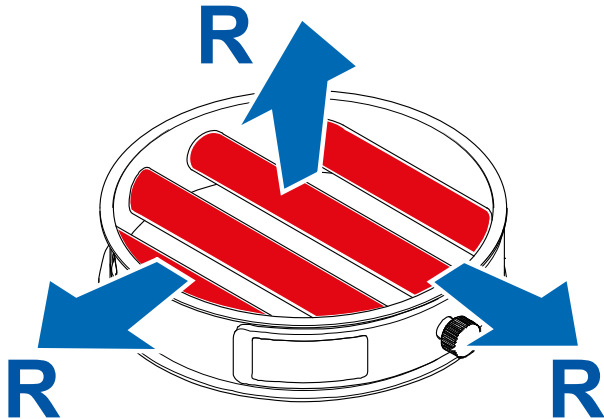

#### **Danger of death to people with implanted medical aids**

People with an active implanted medical aid (e.g. pacemaker, defibrillator, insulin pump) must not be present within a radius 'R' of 0.25 metres of the device.



#### **Damage to products with sensitivity to magnets**

Products that contain ferromagnetic parts, such as debit cards, credit or chip cards, keys and watches, may be rendered permanently damaged if they come within a radius 'R' of 0.10 metres of the device.



Employees who are pregnant and the general public may not come within a radius 'R' of 0.03 metres of the device.

Limit values for occupational exposure (general and for limbs) are not exceeded.



#### **NOTICE**

Goudsmit Magnetics offers measurement inspection to measure the safe clearances of the in-built device on site in order to determine whether they deviate from the values specified above.

## 4 Specifications

### 4.1 Range of application

Magnetic grids are often placed at the inlet point to incoming product flows and filter very fine (weak) magnetic ferrous contamination from free-flowing powders and granulates. The devices often exercise a check function. Here, the extractor is in contact with the product flow. Ferromagnetic particles are magnetically attracted as they pass by and are captured by the powerful extractor.

They are used for applications in the plastics, food, pharmaceuticals and ceramics industries, amongst others. In the hopper of you injection moulding machine, to protect your installation or as final inspection of your product, often just prior to packaging.

### 4.2 Description of function

Magnetic grids comprise multiple very powerful Neoflux® (neodymium) magnetic bars. These are located in the centre of the product flow and can capture the smallest ferrous particles to 30 microns. They are even capable of capturing stainless steel scrapings. These particles are so small that they cannot even be detected by a metal detector.

An effective use is to place two magnetic grids one above the other, with magnetic bars offset above one another. This configuration will force the product to come into contact with the magnetic bars as it passes by, or at least very close to them.

### 4.3 Structure and materials information

Goudsmit magnetic grids are available in square and round versions.

The neodymium magnetic bars are provided with enveloping extractor tubes. This makes the grid more robust and renders manual wiping unnecessary. By pulling the magnetic bar unit out of the extractor tubes, the captured metal contaminants fall off on their own. We call this 'manual quick cleaning'.

The extractor tubes also serve to protect the magnetic bars, making them last longer.

### 4.4 Use in food product flows



#### **WARNING**

#### **Note!**

Moisture or moist products can affect operation of the device in the product flow.

The device is supplied as an AISI316L stainless steel model as standard, with a 3 µm ceramic grit-blasted finish. This is suitable for normal food contact applications. Because of its resistance to corrosion, this material is generally considered safe for use as a material that comes into contact with food products. All contact materials are compliant with EU regulation EC1935/2004.

### 4.5 Models available – specials

#### **Higher product temperatures**

If the device is placed in a warm environment (>80°C), standard Neoflux® magnets can no longer be used. As an example, high-temperature Neoflux® magnets can be used with product and ambient temperatures of up to 150°C. A different magnet material may be suitable for even higher temperatures. Samarium Cobalt magnets are also extremely strong and can withstand temperatures of up to 250°C, while Ferroxdure (much weaker) can withstand temperatures of up to 225°C.

#### **Abrasive products**

If you have an abrasive product, we can give the surface of the extractor a protective coating, such as a coating of tungsten carbide.

## 4.6 Temperatures

The devices are suitable for the following ambient and product temperatures:

Applied magnet quality	Ambient temperature non-ATEX	Max. product temperature
GSN-42	-20°C to +60°C	60°C
GSN-42SH	-20°C to +60°C	100°C
GSN-45SH	-20°C to +60°C	100°C
GSN-52	-20°C to +60°C	60°C

The magnetic material must be protected against higher temperatures than those specified on the data sheet as the magnet will permanently lose magnetic force if exposed to higher temperatures.

## 4.7 Free space

Ensure there is sufficient space around the device for operation and inspection and maintenance work.

## 4.8 ATEX (if applicable)

The mechanical composition of the standard device is free from its own sources of ignition and thus falls outside the scope of the ATEX Directive 2014/34/EU. The full explanation is provided in the ATEX exclusion declaration.



## 5 Product information

### 5.1 Overview drawing

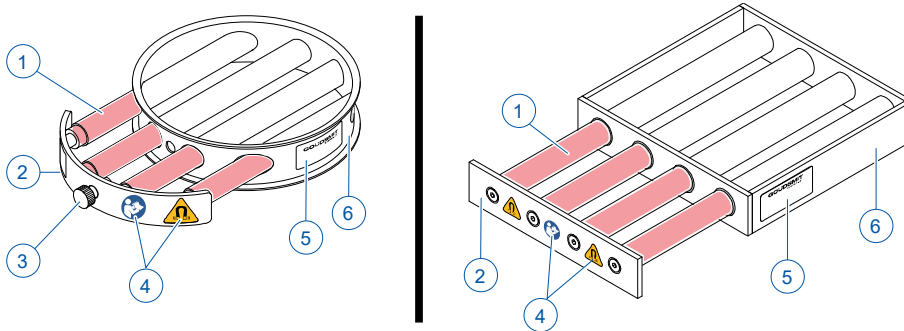

- |                  |                      |                         |
|------------------|----------------------|-------------------------|
| 1. Magnetic bars | 3. Locking button    | 5. Identification plate |
| 2. Magnet unit   | 4. Warning pictogram | 6. Extractor            |

### 5.2 Scope of delivery

Check the shipment immediately upon delivery for:

- Possible damage and/or shortcomings as a consequence of transport. In the event of damage, ask the carrier for a transport damage report.
- Completeness.



#### NOTICE

In the event of damage or incorrect shipment, contact Goudsmit Magnetics immediately. The contact details are provided on the title page of this manual.

### 5.3 Identification plate

The following identification data are shown on the device. The identification data are very important for maintenance of the device.

Always keep the identification data clean and legible. Always provide the article and order numbers when ordering spare parts, requesting service or reporting a malfunction.

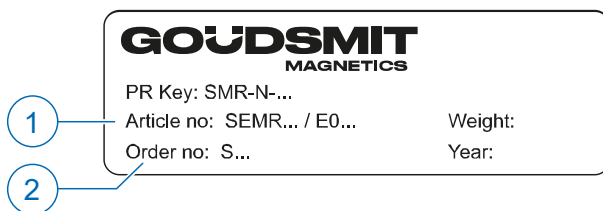

1. Article number
2. Order number

## 6 Transport and installation

### 6.1 Transport



#### WARNING

##### Note

The device permanently emits a magnetic force.

Observe the safety instructions for transport in the Safety [▶ 5] section.

- During transport, avoid all impact in order to prevent damage, especially to the magnetic bars. In the event of damage to the tubes, the magnet packs may not move in the tubes, or only move with difficulty.

### 6.2 Installation



#### NOTICE

Take the following precautions:

- ▶ Work safely, provide ample work space and use dependable scaffolding, ladders and other tools so the device can be installed without any risks.
- ▶ The device permanently emits a magnetic force. See the Safety [▶ 5] section for the precautions that must be taken when working on the device.
- ▶ Only qualified personnel should work on the device.
- ▶ Ensure that there is sufficient clearance around the installation to install the device in the installation/structure and for operation, inspection and maintenance work to be carried out.
- ▶ Ensure that no external vibration is transferred to the device, as this can cause permanent loss of magnetic force.
- ▶ Only non-magnetic structural parts are permitted within the range of the magnetic field in order to prevent a negative impact on the removal of ferrous particles. In simple terms, the magnetic field may not be 'short circuited'.
- ▶ Only use lifting/hoisting tools that are in good condition, and do not exceed the lifting capacity of the tools.
- ▶ The supply and discharge channels and structure must be sufficiently strong to bear the weight of the device with the captured ferrous particles.



#### WARNING

##### Note

When transporting and installing the device, ensure that the magnet unit does not fall out of the extractor. This is mainly a concern for the square version. On the round version, the magnet unit is secured with the locking button.

- Install the device free of mechanical stress and at the correct working height in your product chute for the operating personnel. Mechanical stress on the device can cause deformation and other problems.
- Install the device in the horizontal orientation in the product chute.

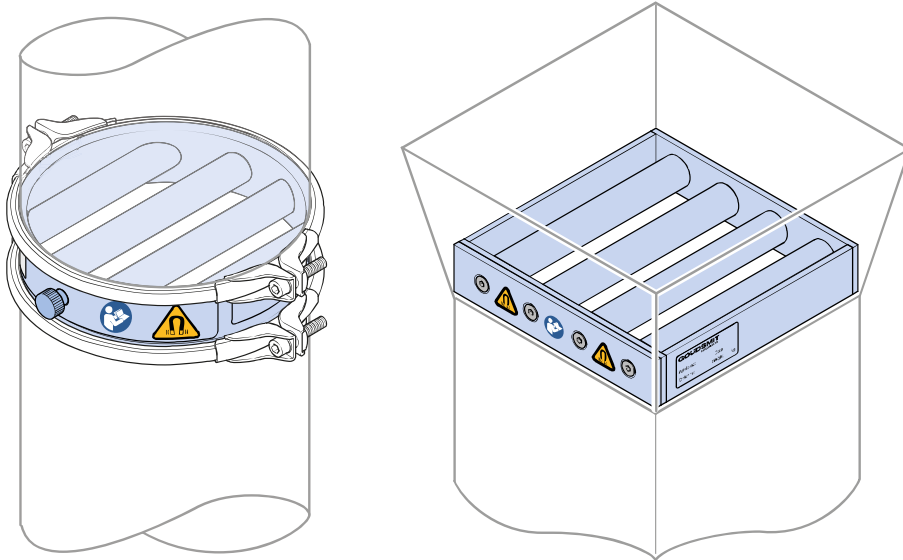

- Use a suitable lifting/hoisting arrangement that supports the weight of the device.
- Remove the lifting/hoisting arrangement after installation is complete.
- Clean the device thoroughly before commissioning.

## 7 Operating principle

### 7.1 General

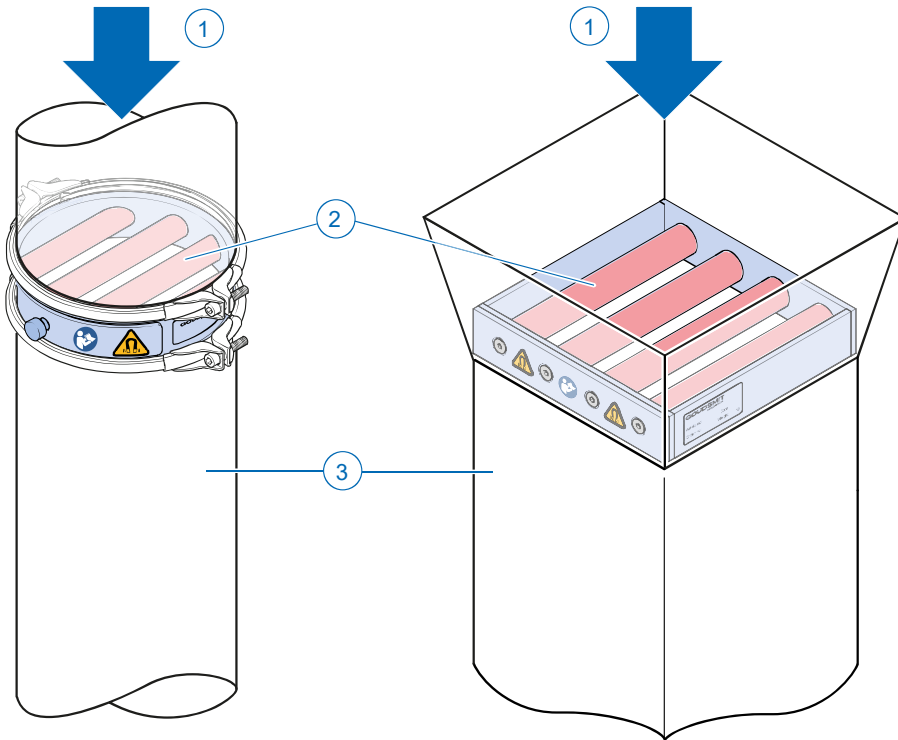

- The magnet unit with very strong neodymium magnetic bars is located in the centre of the product flow. The product contaminated with ferromagnetic particles [1] passes several magnetic bars [2] while flowing through the grid.
- The magnets attract passing ferromagnetic contaminants. The captured particles [2] stick to the magnets, while the purified product [3] flows on.

### 7.2 Cleaning process – removal of ferromagnetic particles

When cleaning the device, wear the requisite protective clothing, such as overalls, gloves, goggles and safety shoes.



Cleaning process – disposal of ferromagnetic particles

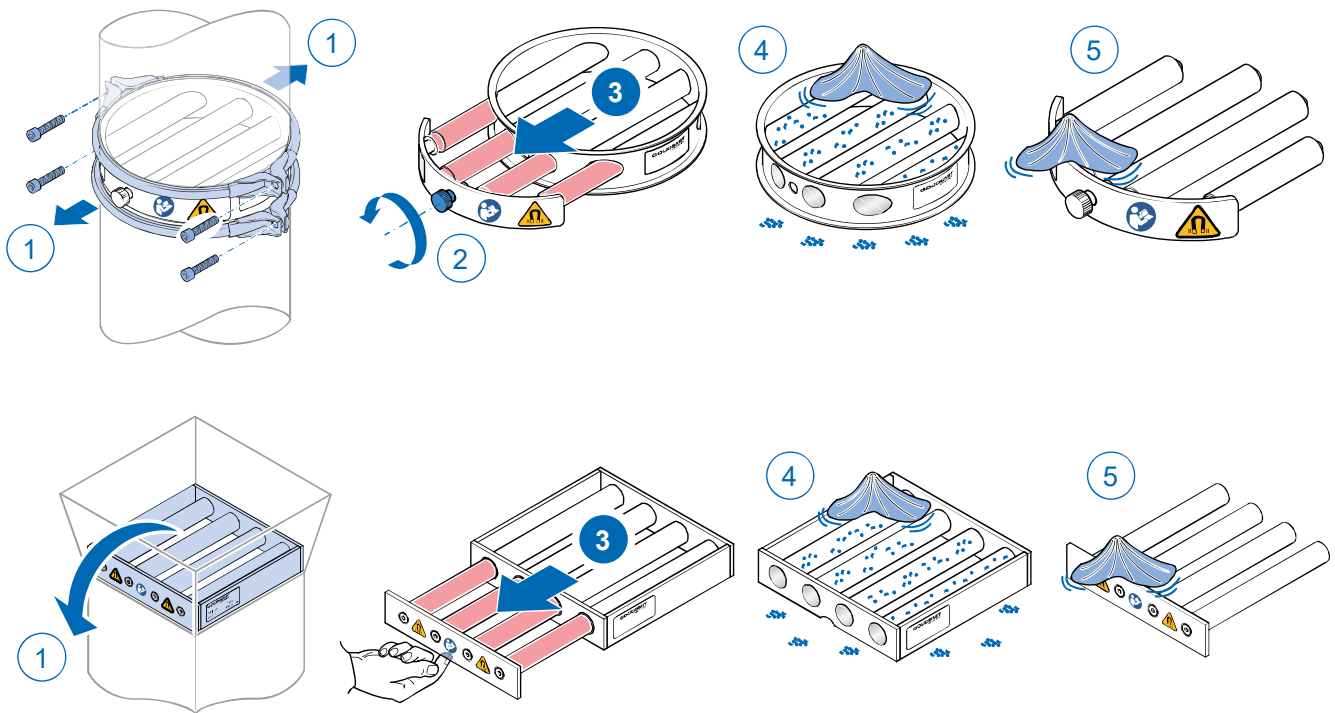

To clean, proceed as follows:

- Stop the product flow.
- Round version: Remove the Jacob clamp ring or DIN 32676 connection from the product chute.
- Remove the device [1] from the product chute.
- Place the device on a pre-cleansed non-magnetic surface (e.g. wood, aluminium or stainless steel).
- Round version: Unlock the magnet unit using the lock button [2].
- Pull the magnet unit out of the extractor [3]. The captured metal particles now fall off the extractor. Make sure to keep the magnet unit away from these metal particles.
- Place the magnet unit on a clean, non-magnetic surface, far enough away from the extractor [3].
- Clean the extractor [4] and the magnet unit [5] with a soft, clean cloth or brush and, if necessary, a suitable cleaning agent.
- Dispose of the metal particles with the contaminants.
- Place the magnet unit back in the extractor.
- Round version: lock the magnet unit using the lock button [2].
- Place the device back in the product chute.
- Round version: Fit the Jacob clamp ring or DIN 32676 connection back onto the product chute.
- Production can be safely resumed.

## 8 Maintenance and inspection

### 8.1 General guidelines



**WARNING**  
**Risk of crushing**

In view of the large magnetic forces, replacing the internal magnet components is extremely dangerous as they are difficult to handle. Replacement may ONLY be carried out by appropriately qualified personnel or (ideally) by Goudsmit Magnetics technicians. If the replacement is carried out by unqualified personnel, the warranty will be void. Goudsmit Magnetics cannot be held liable for any consequential damage to people and/or materials if this prohibition is ignored.



**WARNING**  
**Caution**

The product flow must be stopped when work is being carried out on the device. Exercise caution with tools. The magnetic force is permanent.

Magnetic systems do not only attract ferromagnetic particles, but a small proportion of your product will also continue to 'adhere' to the magnet. Remove all captured particles from the magnet at regular intervals. A clean magnet is considerably more effective.

- Always inform operating personnel of scheduled inspections, maintenance, repairs and in the event of faults.
- Check regularly that all warning pictograms are still present in the correct locations on the device. If these are lost or damaged, replace them with new pictograms in the original locations immediately.
- Ensure that the device is externally clean. Remove dust, dirt and particles from the device as appropriate.

### 8.2 Frequency of maintenance



**NOTICE**

Goudsmit Magnetics offers an annual maintenance inspection and an inspection report with certificate for the magnets.

Action	Daily	Monthly
Clean magnetic bar tubes (for maximum performance) (► Cleaning instructions).	min. 2x <sup>1)</sup>	
Measure flux density of magnetic bars (► Flux density measurement of the magnetic bars).		•
Check magnetic bar for wear.		•

<sup>1)</sup> The frequency of the cleaning process depends on the capacity of your product flow and the level of soiling.

### 8.3 Cleaning instructions

**When used in food product flows**

Cleaning and disinfectant methods and agents that are used for cleaning must be adapted to the specific type of soiling (carbohydrates, proteins, fats, etc.) and the degree of cleaning required for your application. The type of product that is processed thus determines to a large extent which combination of cleaning agents is suitable. Consult your cleaning agent supplier to select the correct cleaning agents for your specific situation.

**Wet or dry cleaning**

If the use of fluids is prohibited in your installation, use disinfectant cloths that are suitable for contact with the processed product, if necessary.

The frequency of cleaning is dependent on the degree of cleanliness required for the processed product. The frequency of cleaning must be increased in applications where sensitive food products are processed. Perform a hygiene risk assessment to determine the requirements in your situation.

The device is made of stainless steel or 'food-grade stainless steel' 1.4404/SAE 316L.

## 8.4 Flux density measurement of the magnetic bars

The magnetic bars must be measured at periodic intervals to check their magnetic flux density and to determine whether the magnetic force has reduced. Use a suitable gauss meter/tesla meter to measure the poles of the magnetic bar on the surface (the unit is tesla, gauss, kA/m or oersted).

Goudsmit Magnetics can perform magnet measurements on location, if desired. Proceed as follows:

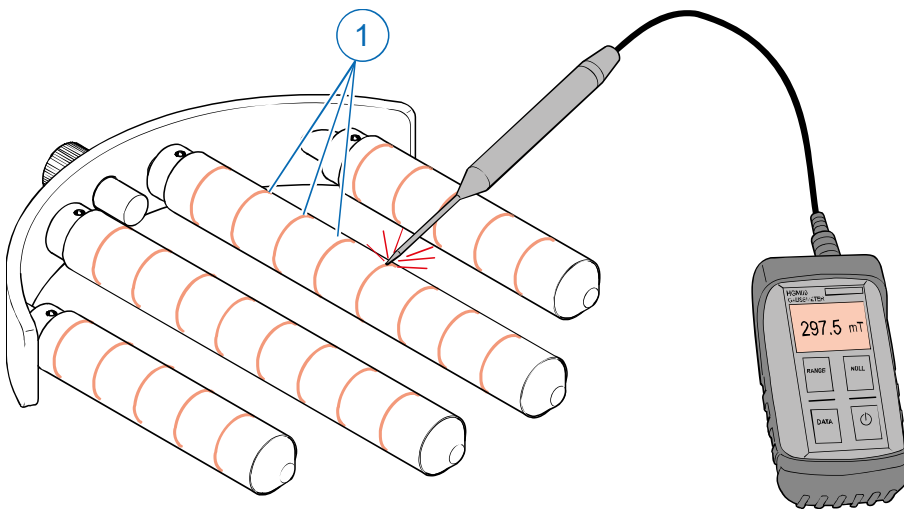

- Stop the product flow.
- Unlock the magnet unit.
- Pull the magnet unit out of the extractor. The captured metal particles now fall off the extractor. Make sure to keep the magnet unit away from these metal particles.
- Clean the magnet unit with a soft, clean cloth or brush and, if necessary, a suitable cleaning agent.
- Using the gauss meter/tesla meter, move along the poles [1] of the magnetic bar.

The measured values may fluctuate for various reasons, such as the position (angle) of the probe on the magnetic bar tube, the thickness of the probe and the reproducibility of the measurement.

- Record the highest measured value.
- Using the accompanying data sheet, check whether the measured value falls within the permitted value of the peak value.
- Place the magnet unit back in the extractor. Secure the magnet unit with the lock button.
- Place the device back in the product chute.
- Production can be safely resumed.

## 9 Troubleshooting

### 9.1 Troubleshooting table

Use the following table to search for faults, determine the possible cause and find the remedy. In the event of a fault that is not in the table, contact Goudsmit Magnetics customer service.

Problem	Possible cause	Solution
The device does not separate ferromagnetic particles completely or at all.	The magnetic bar is overloaded with ferromagnetic particles.	<ul style="list-style-type: none"> <li>● Remove the captured particles from the magnetic bar (more frequently).</li> <li>● Use a permanent magnet to check whether the separated particles are ferromagnetic.</li> </ul>
	Particles that are not attracted are not sufficiently ferromagnetic.	<ul style="list-style-type: none"> <li>● Check the magnetic behaviour of the installed parts around the magnets by holding an iron part close to the magnets. If there are parts that react to the magnet, replace them with non-magnetic parts, such as those made from stainless steel.</li> </ul>
Magnet unit jams in extractor element.	Dents in the extractor tubes.	<ul style="list-style-type: none"> <li>● Remove the dents from the extractor tubes.</li> <li>● Order a new extractor.</li> </ul>



## 10 Service, storage and disassembly

### 10.1 Customer service

Have the following information to hand when contacting customer service:

- Data from the identification plate.
- Type and scope of the problem.
- Presumed cause.

### 10.2 Spare parts

The high quality of the products from Goudsmit Magnetics means that the magnet product is highly reliable in operation.

However, if a particular part needs to be replaced, you can order a new one by providing the type number listed on the identification plate or on the attached drawing(s) and/or the data sheet.

- When ordering, state the article and order numbers that appear on the identification plate.
- For further information, please contact us by +31 (040) 22 13 283 or consult our website.

Spare parts are usually parts that are subject to wear. These include:

- Magnetic bars
- Extractor element

See the data sheet for the precise specifications. Please get in touch with us for information on the availability of spare parts.

### 10.3 Storage and disposal

#### Storage

If you do not intend to use the magnet product for an extended period of time, we recommend placing the device in a dry, safe place, and applying preservative to the vulnerable parts, if necessary.

#### Disposal/recycling

When dismantling and/or scrapping the magnet product, keep in mind the materials from which the individual parts are made (magnets, iron, aluminium, stainless steel, etc.). This should ideally be done by a specialised company. Always observe the local regulations and standards pertaining to industrial waste disposal.

Inform those disposing of or storing the magnet material of the hazards of magnetism. To this end, see also the Safety [► 5] section.





