

DOC.NR.	REV	DATE	BY	DESCRIPTION
GM16007	-	24-9-2019	PV	ORIGINAL DRAWING

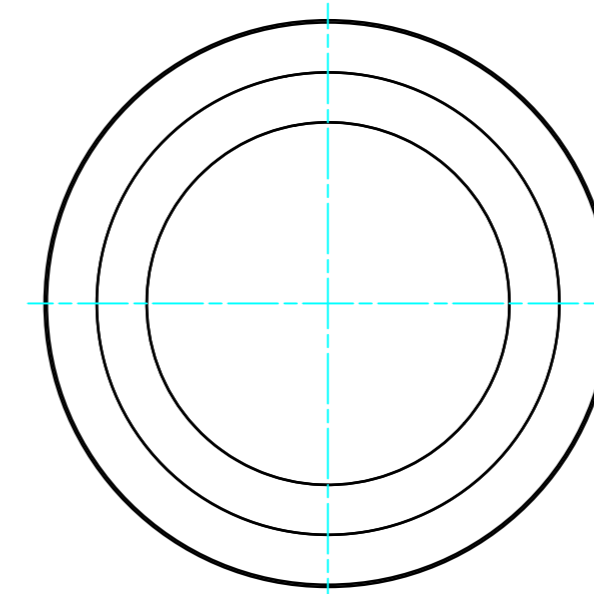

A = LENGTH BY WHICH THE BAR MAGNET CAN BE SHORTENED OR MACHINED WITHOUT BEING DAMAGED

RAW MAT.	1	Quantity	Material Number	Material Description	Length (mm)	Width (mm)
Drawn:	PV	Weight (kg):	0,11	Extra info:	POTMAGNET AINICO	
Date:	5-8-2019	General tolerance:	ISO 2768- mK			
Spare part:	False	Drawn according:	ISO268; ISO1101; ISO2553			
Quick search:	POTGM	Status:	Standard			
Description:	PM-BM-A-ST-D25h6x30			Customer reference number:	GM16007	
		Document number:	GM16007		Doc.Rev:	-
		Part number:	GM16007		Rev:	-

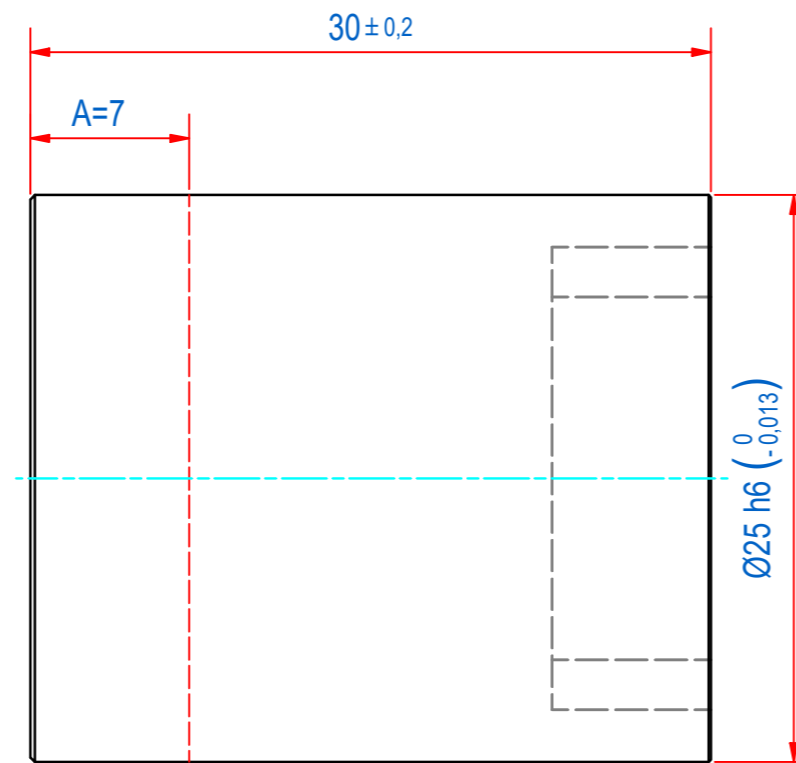
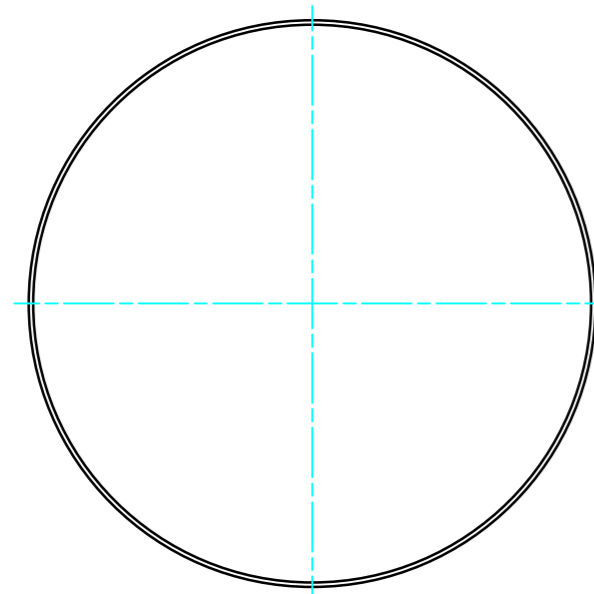
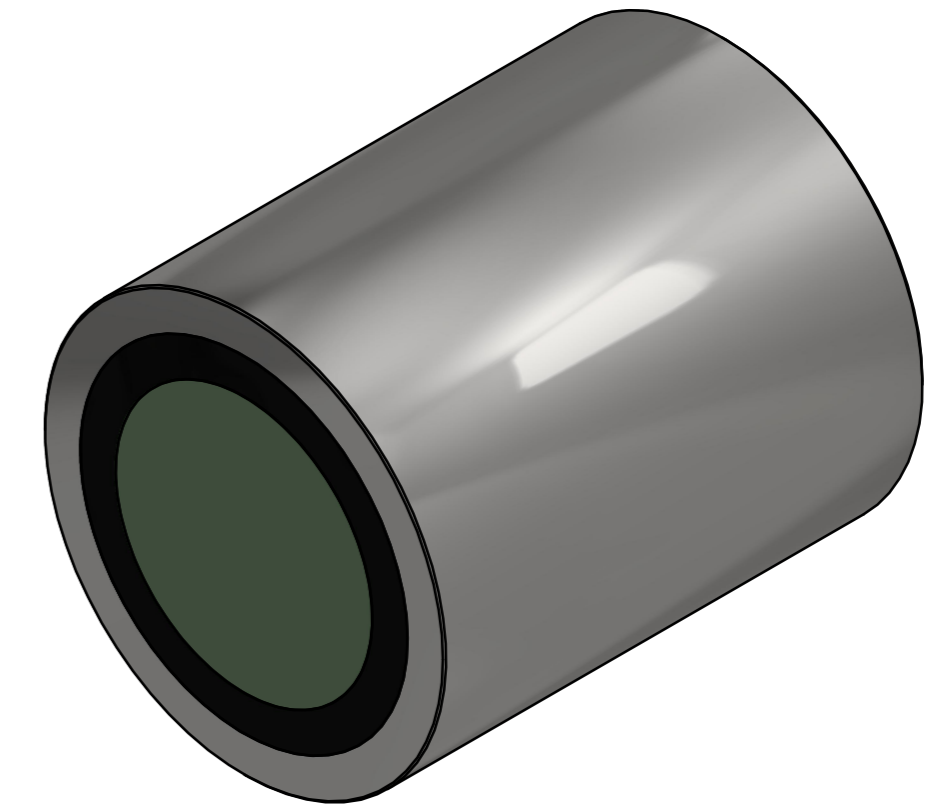
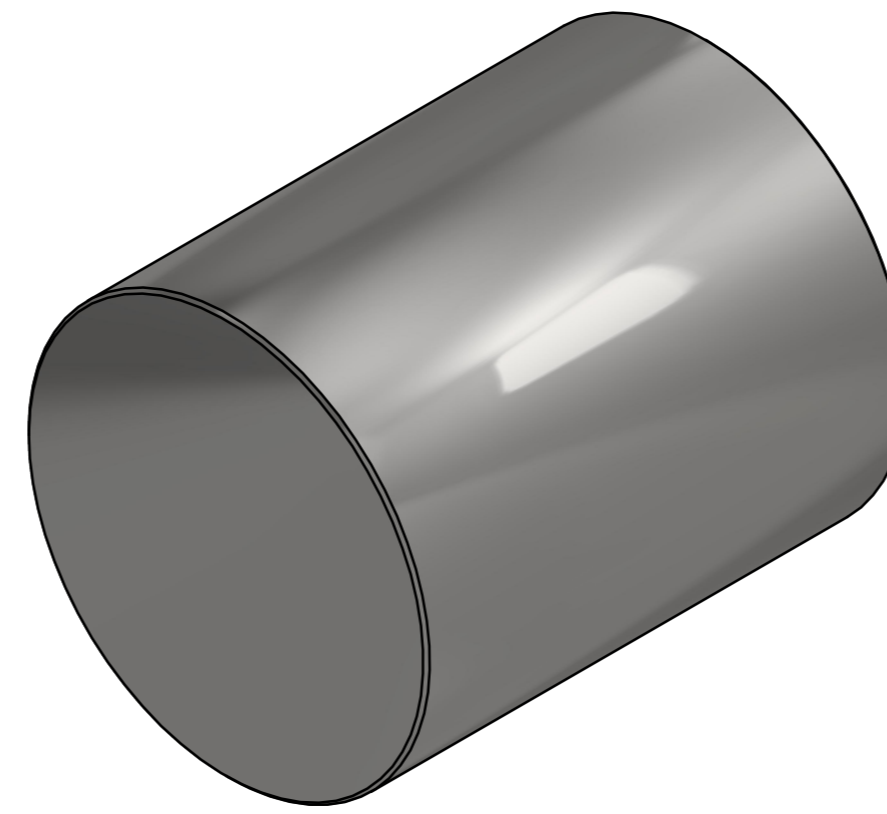

© All rights reserved. Reproduction is not permitted without written permission of GOUDSMIT Magnetic Systems BV