

DOC.NR.	REV	DATE	BY	DESCRIPTION
GM16102	-	29-6-2020	TM	ORIGINAL DRAWING

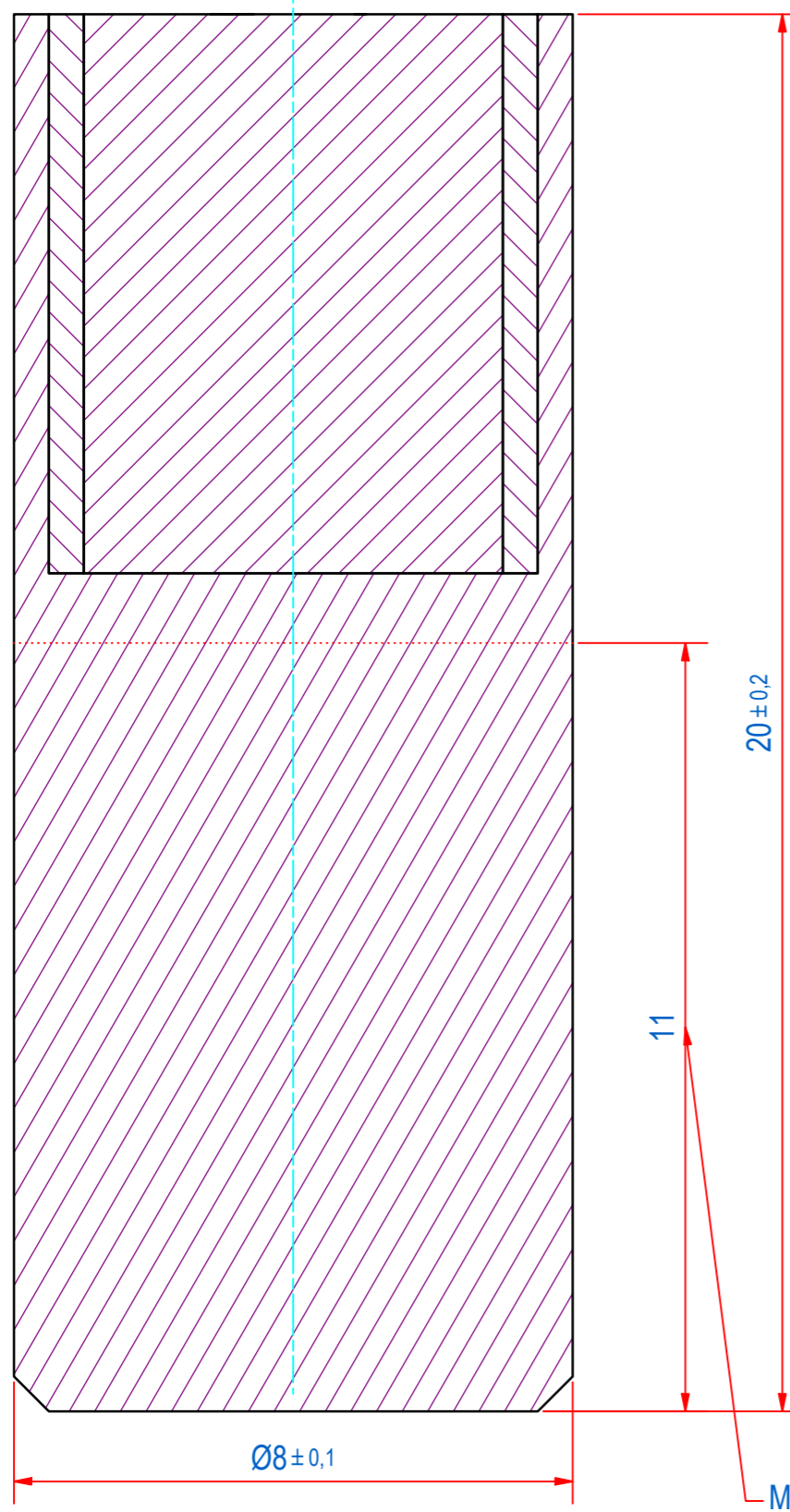
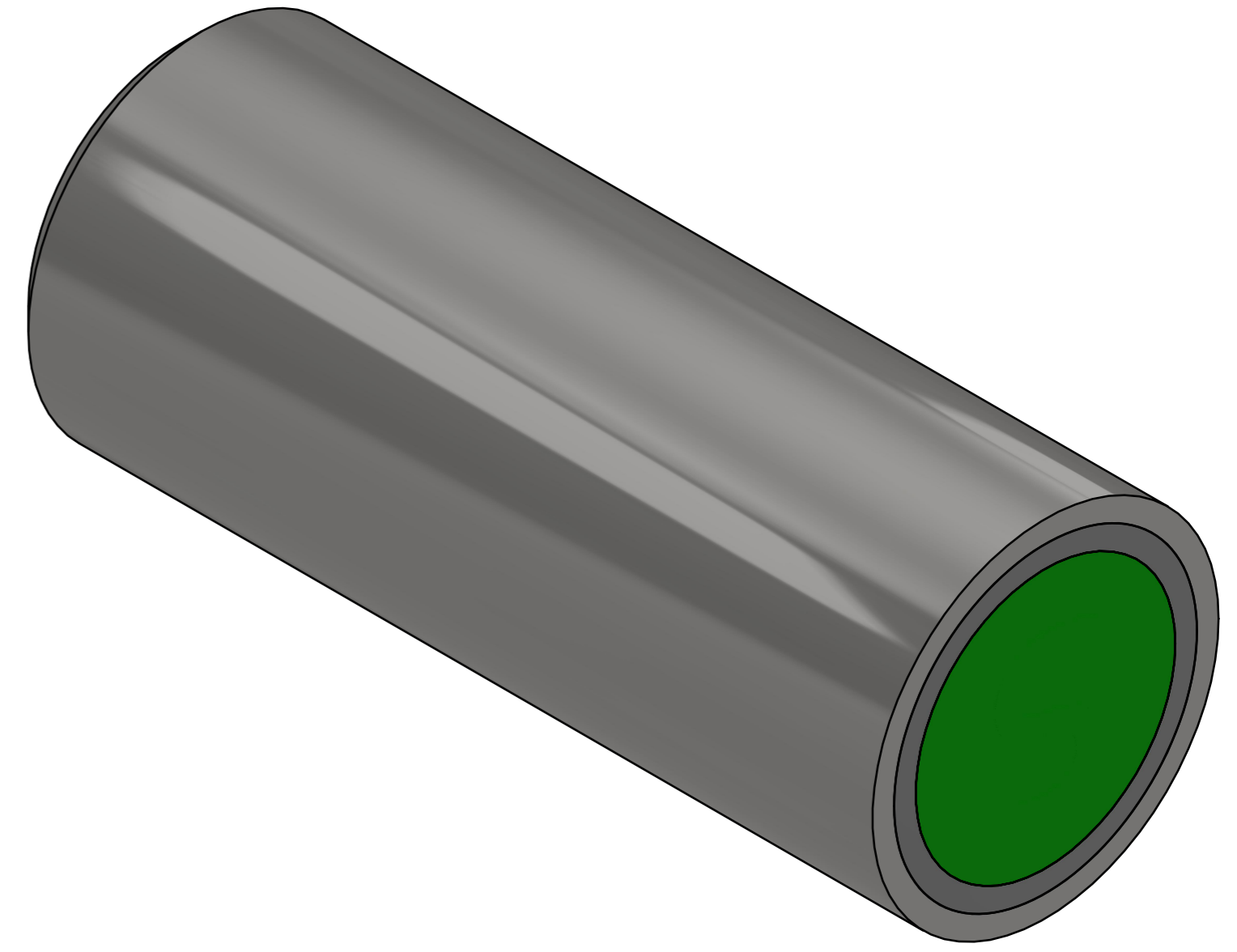
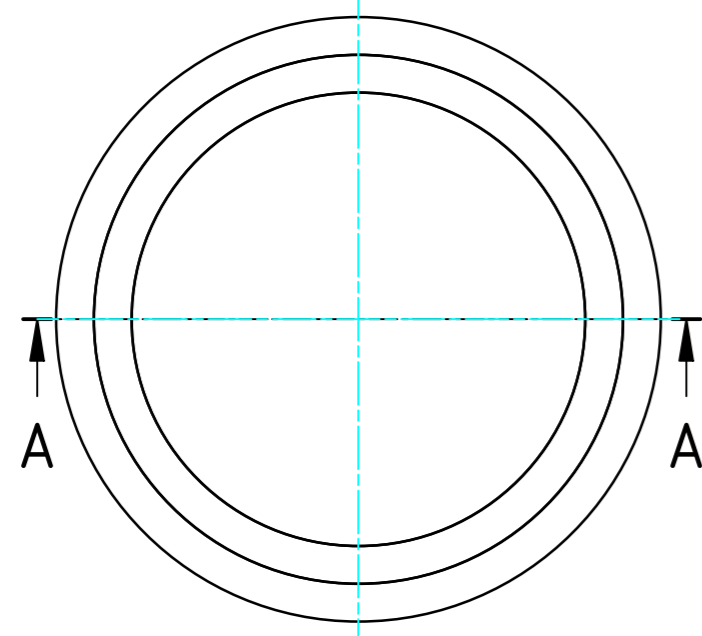

Max. length by which the bar magnet can be shortened or machined without being damaged.

RAW MAT.	1								
Quantity		Material Number		Material Description		Length (mm)		Width (mm)	
Sheet:	A2	Extra info:	POT MAGNET AINICO		General tolerance:		ISO 2768- mK		
Drawn:	TM	Weight (kg):	0,007		Drawn according:		ISO268; ISO1101; ISO2553		
Date:	29-6-2020			Status:		Standard			
Spare part:	False			Customer reference number:		S8			
Quick search:	POTGM	© All rights reserved. Reproduction is not permitted without written permission of GOUDSMIT Magnetic Systems BV		Document number:		GM16102			
Description:	PM-BM-A-SG-D8x20				Part number:		GM16102		