

DOC.NR.	REV	DATE	BY	DESCRIPTION
GM16250	-	3-7-2020	TM	ORIGINAL DRAWING
GM16250	A	3-7-2020	TM	FILLET ON MODEL ADDED

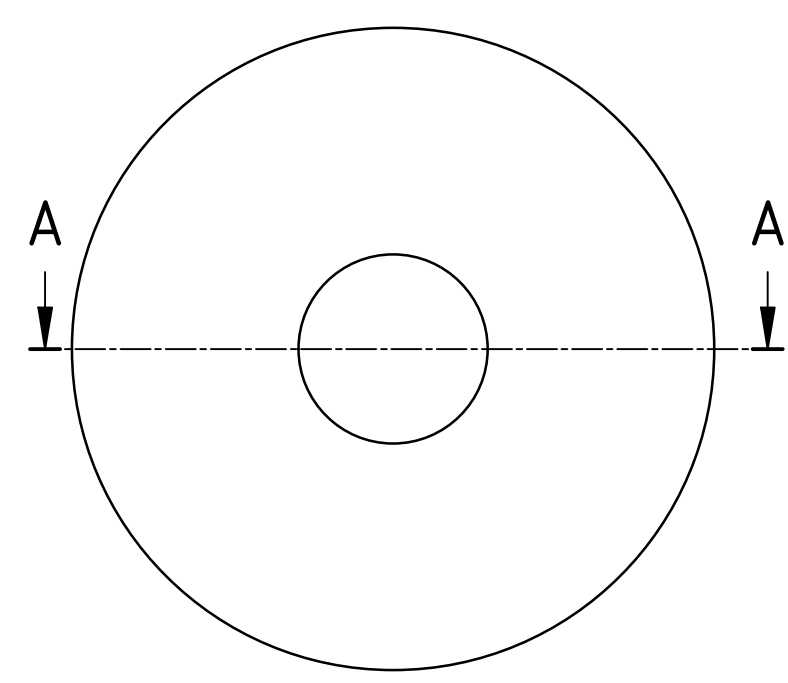
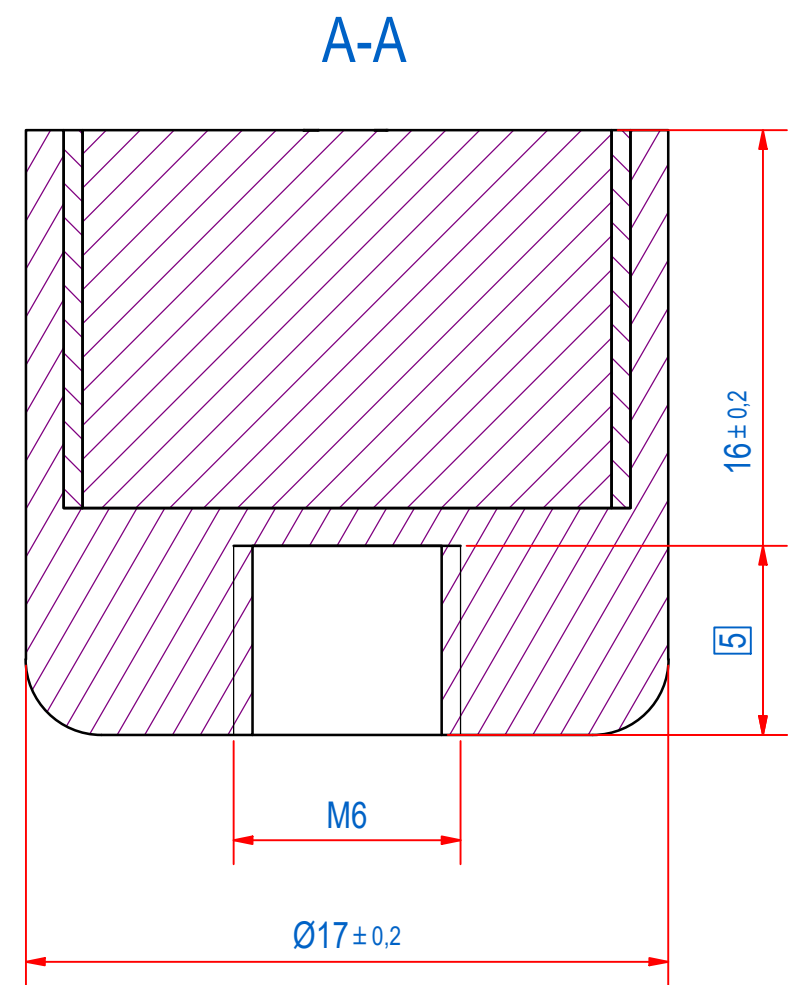
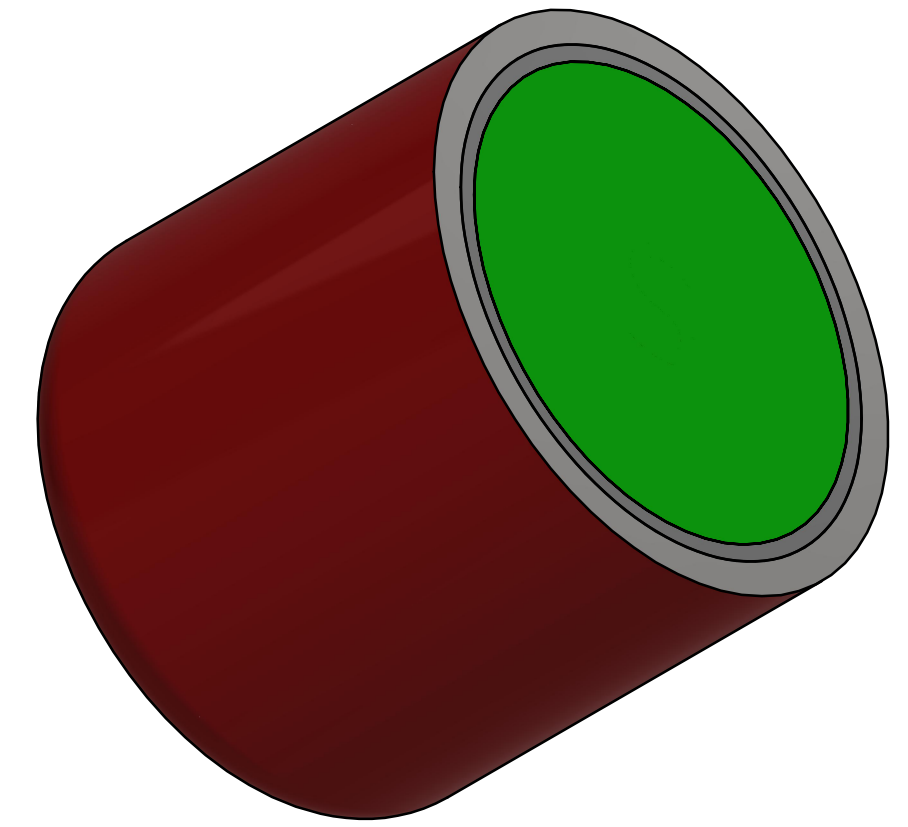

RAW MAT.	Quantity	Material Number	Material Description	Length (mm)	Width (mm)
	1				
Sheet:	A2		Extra info: POTMAGNET AINICO	General tolerance: ISO 2768- mK	
Drawn:	TM	Weight (kg): 0,025		Drawn according: ISO268; ISO1101; ISO2553	
Date:	3-7-2020			Status: Standard	
Spare part:	False			Customer reference number: S17R	
Quick search:				Document number: GM16250	Doc.Rev: A
Description:	PM-TI-A-SR-D17x16xM6x5			Part number: GM16250	Rev: A