

DOC.NR.	REV	DATE	BY	DESCRIPTION
GM16505	-	25-9-2019	PV	ORIGINAL DRAWING

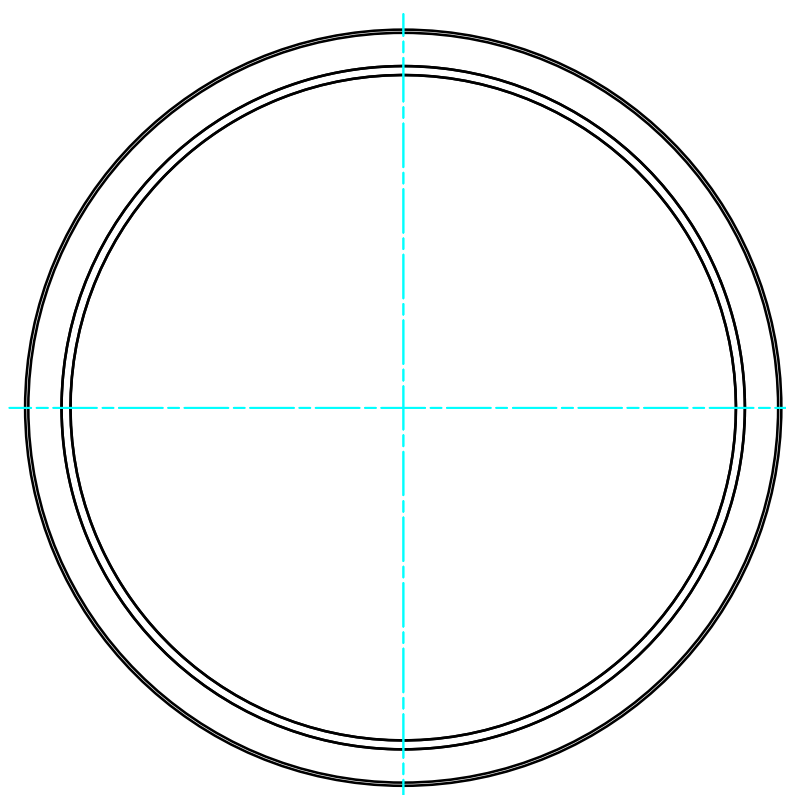
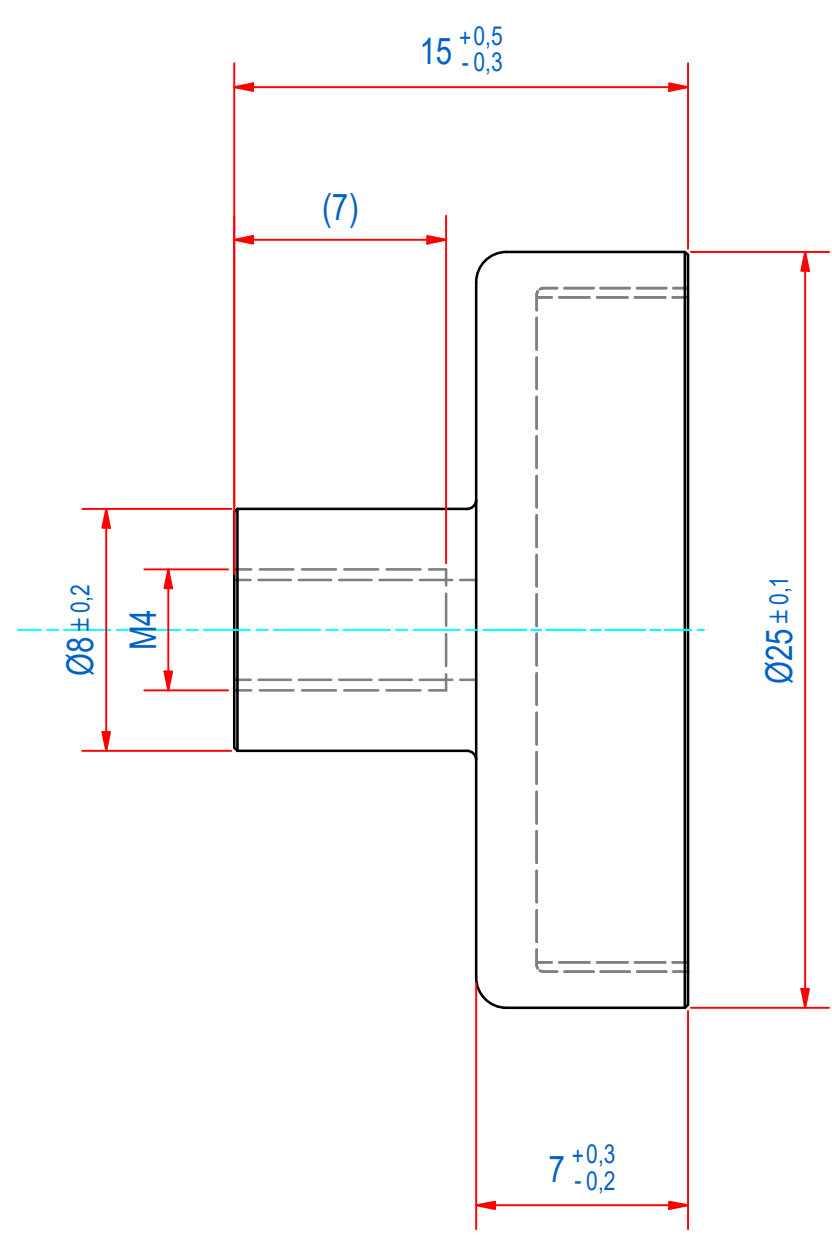
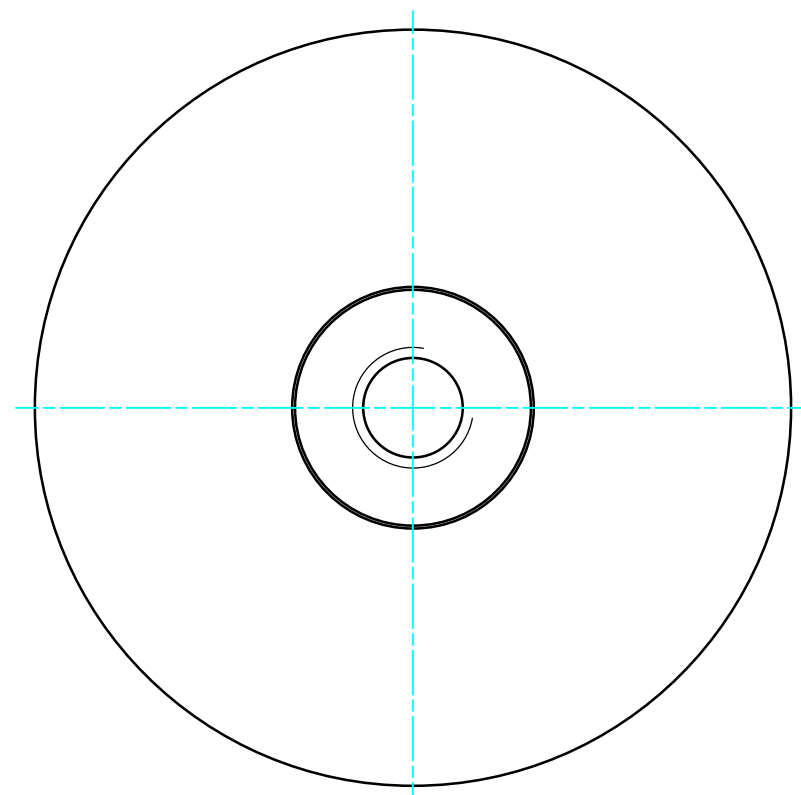
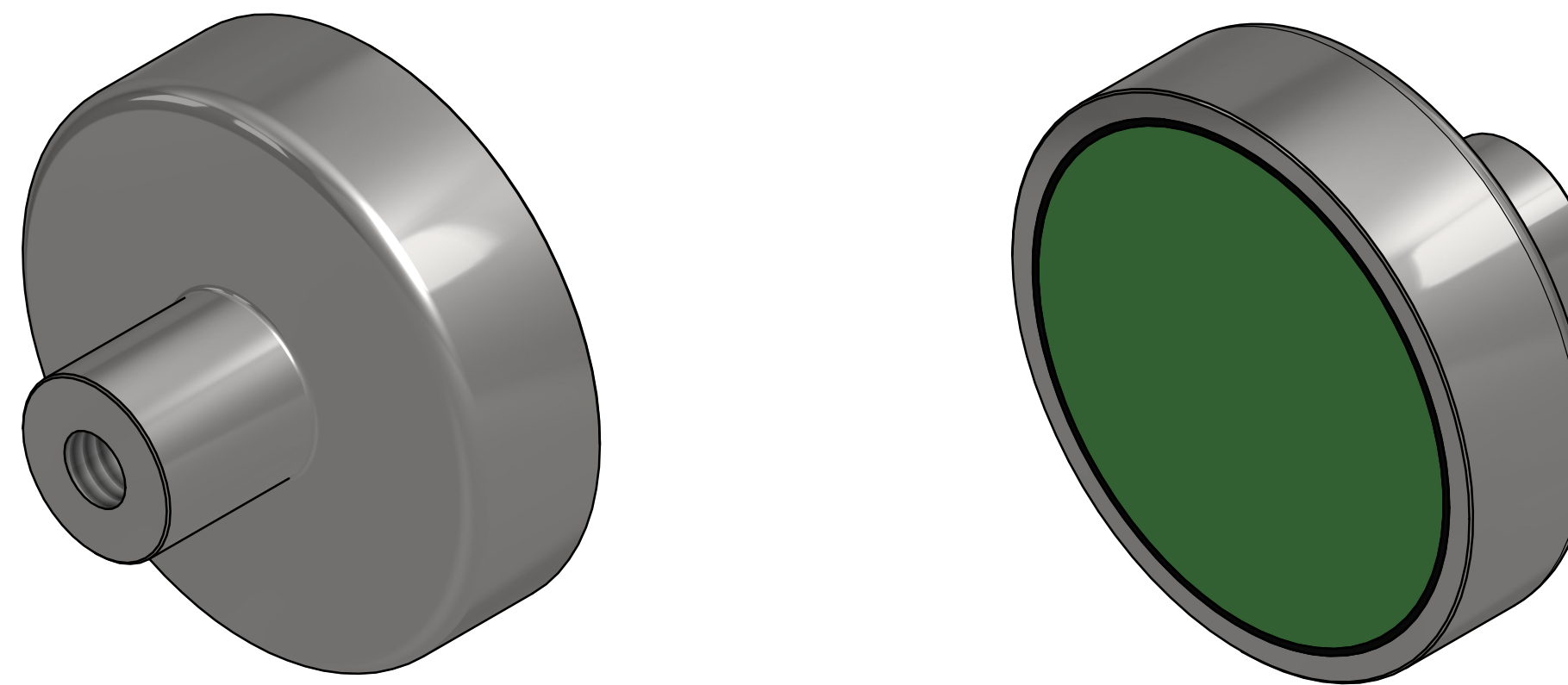

SURFACE TREATMENT: ZINC PLATED

RAW MAT.	1	Quantity	Material Number	Material Description	Length (mm)	Width (mm)
Symbol	Sheet: A2	Extra info:	POTMAGNET FERRITE		General tolerance: ISO 2768- mK	
Drawn: PV	Weight (kg): 0,029	Date: 23-9-2019		Drawn according: ISO268; ISO1101; ISO2553		
Spare part: False	Source:	Quick search: POTGM		Status: Standard		
Description: PM-TB-F-SG-D25x7x15xM4		GOUDSMIT MAGNETICS		Customer reference number:		
		© All rights reserved. Reproduction is not permitted without written permission of GOUDSMIT Magnetic Systems BV		Document number: GM16505 Doc.Rev: -		
				Part number: GM16505 Rev: -		