

DOC.NR.	REV	DATE	BY	DESCRIPTION
GM16509	-	25-9-2019	PV	ORIGINAL DRAWING
GM16509	A	22-6-2020	TM	TOLERANCE 30(+0.6/-0.3) CHANGED TO 30(+0.7/-0.3)

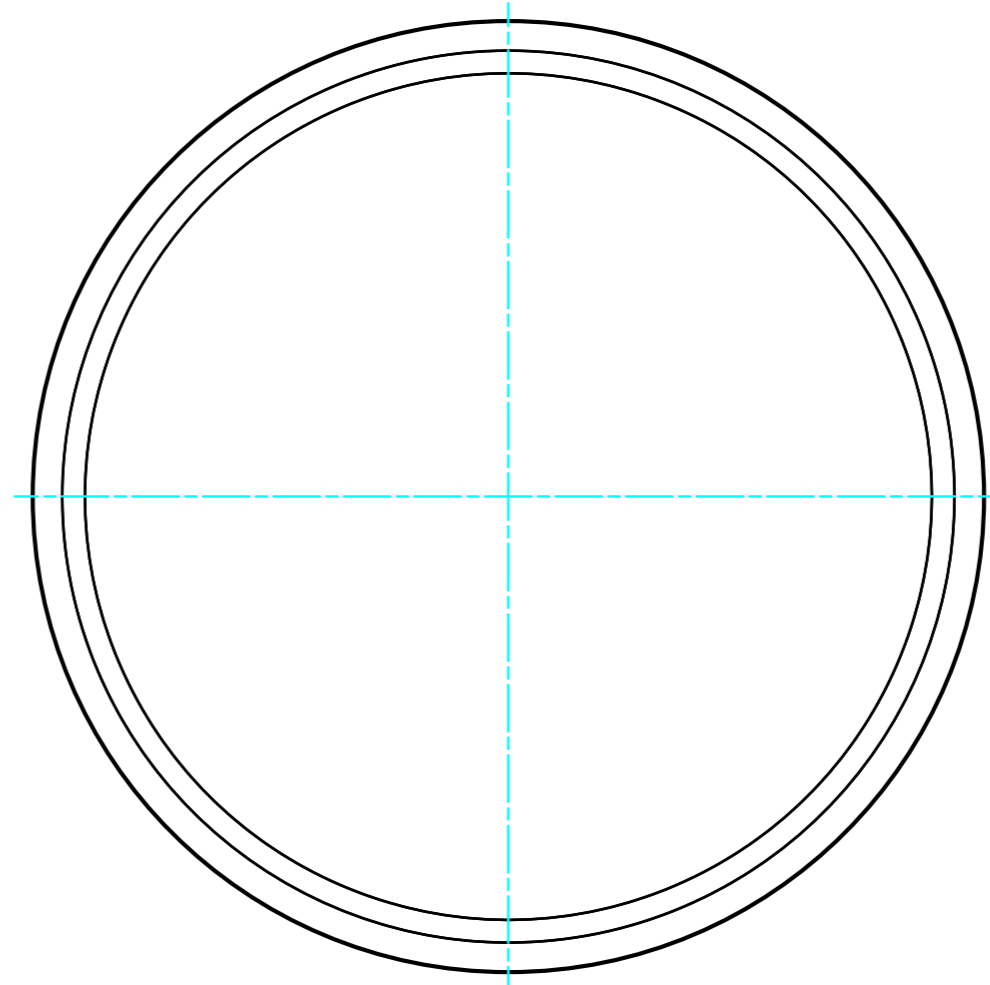

SURFACE TREATMENT: ZINC PLATED

RAW MAT.	1	Quantity	Material Number	Material Description	Length (mm)	Width (mm)
Symbol	Sheet: A2	Extra info: POT MAGNET FERRITE	General tolerance: ISO 2768- mK			
Drawn: PV	Weight (kg): 0,34	Drawn according: ISO268; ISO1101; ISO2553				
Date: 23-9-2019	Source:	Status: Standard				
Spare part: False	Quick search: POTGM	Customer reference number:				
Description: PM-TB-F-SG-D63x14x30xM8			Document number: GM16509	Doc.Rev: A		
			Part number: GM16509	Rev: A		

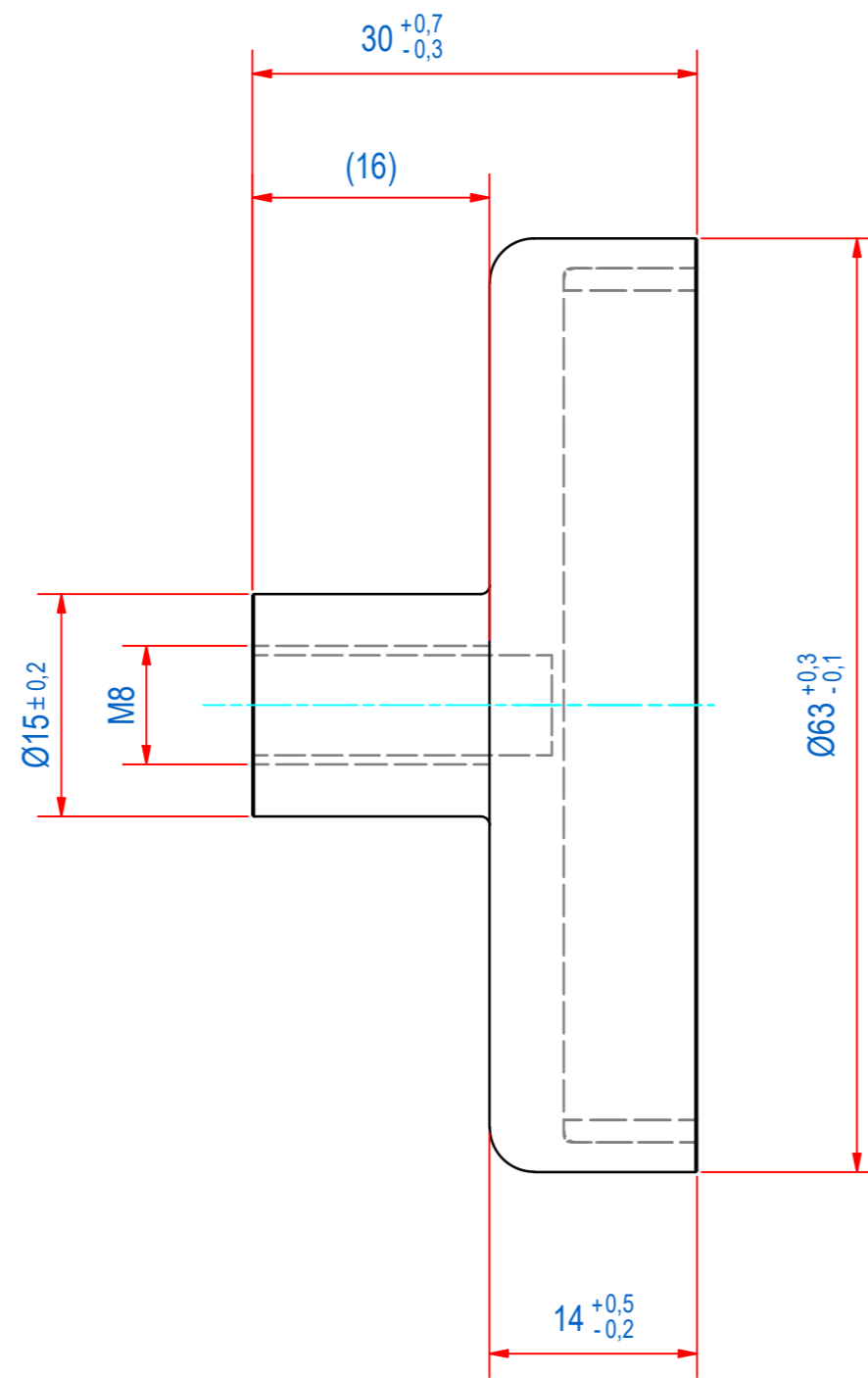
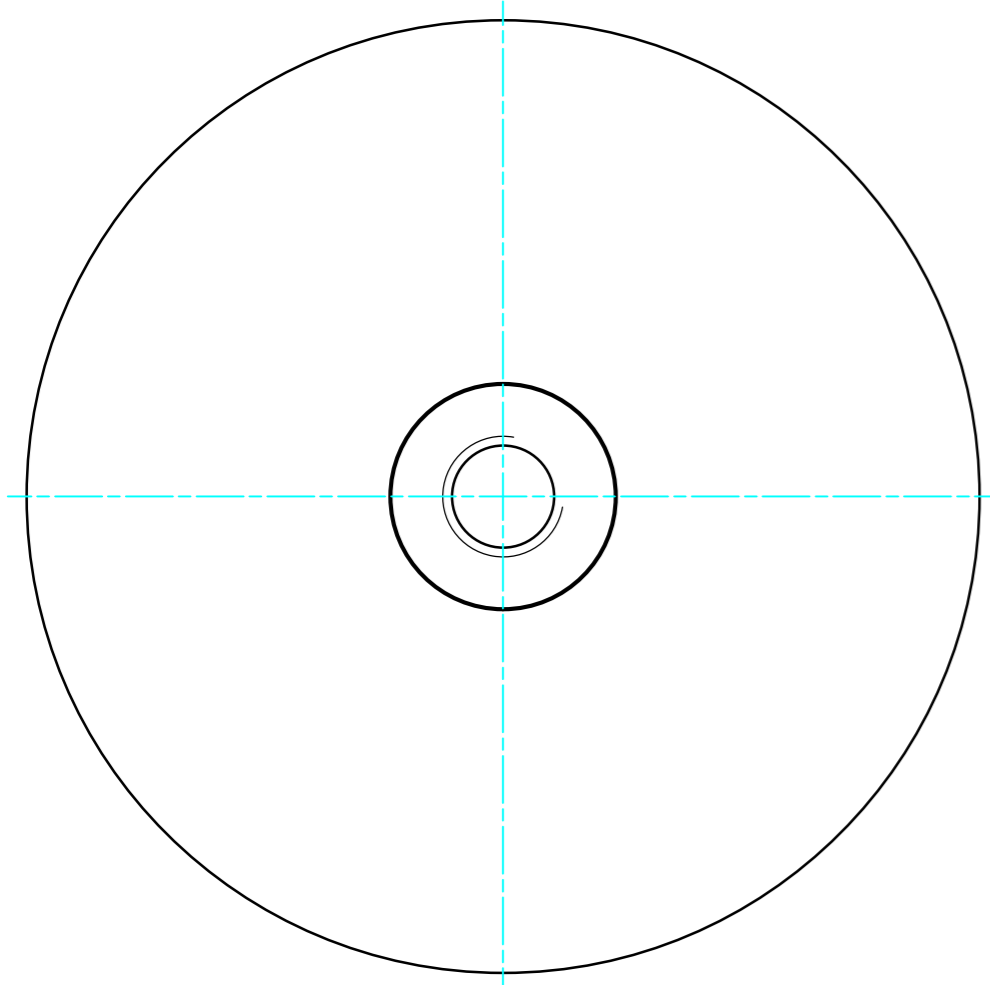
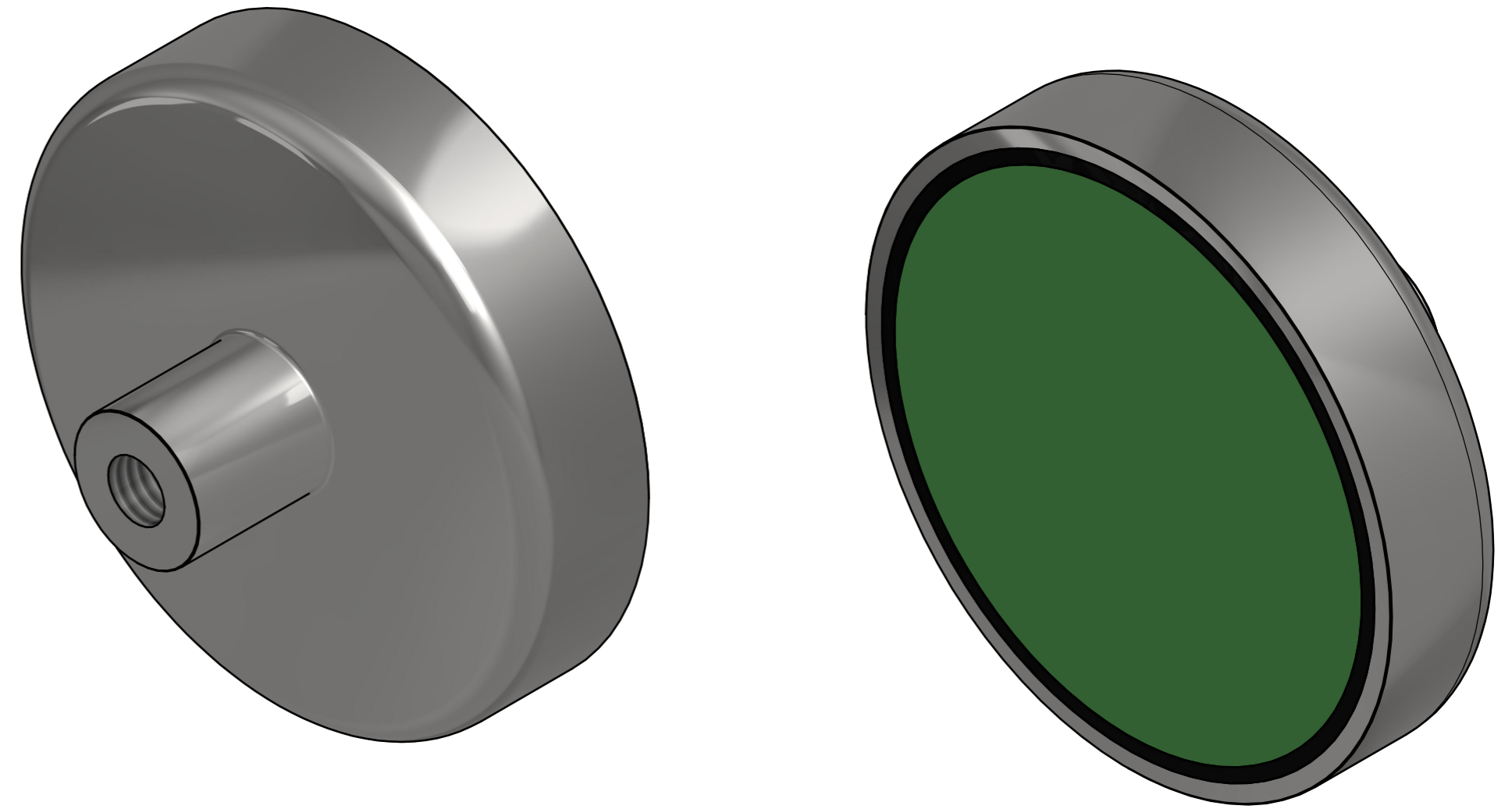

© All rights reserved. Reproduction is not permitted without written permission of GOUDSMIT Magnetic Systems BV