

DOC.NR.	REV	DATE	BY	DESCRIPTION
E0120181	-	25-9-2019	PV	ORIGINAL DRAWING

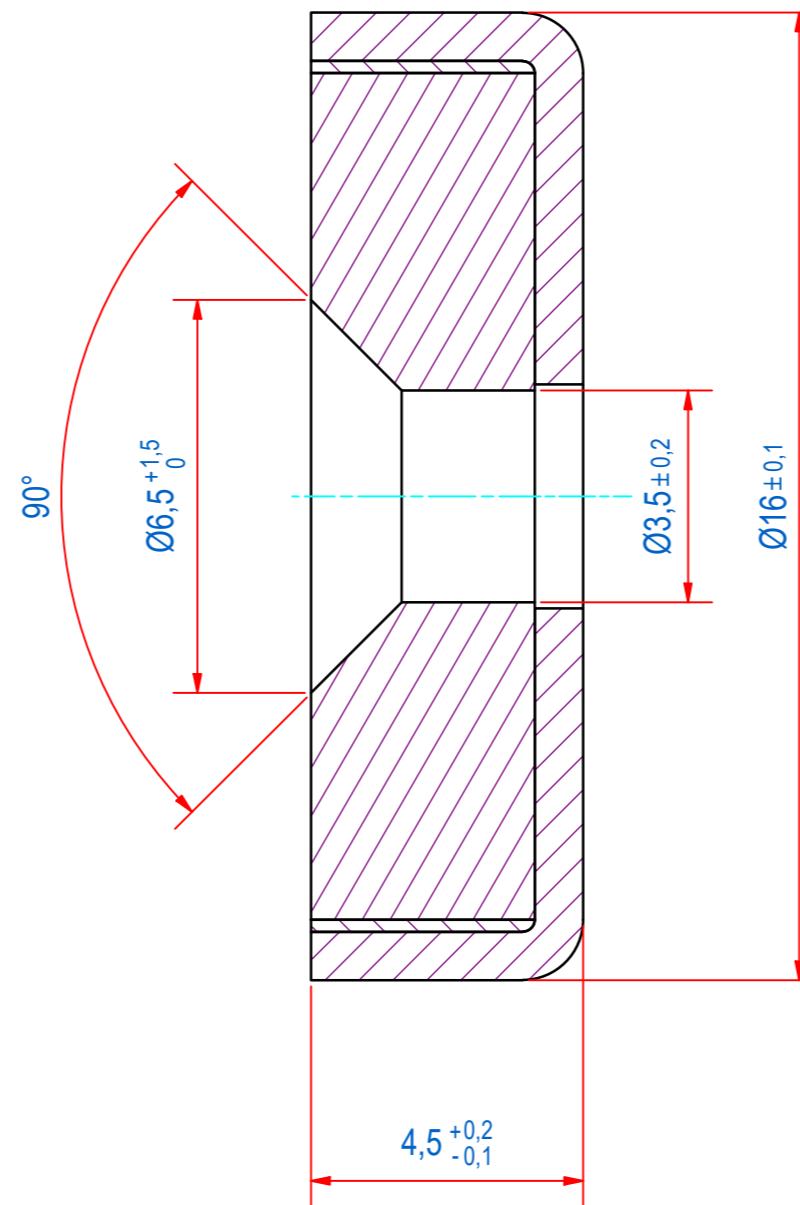
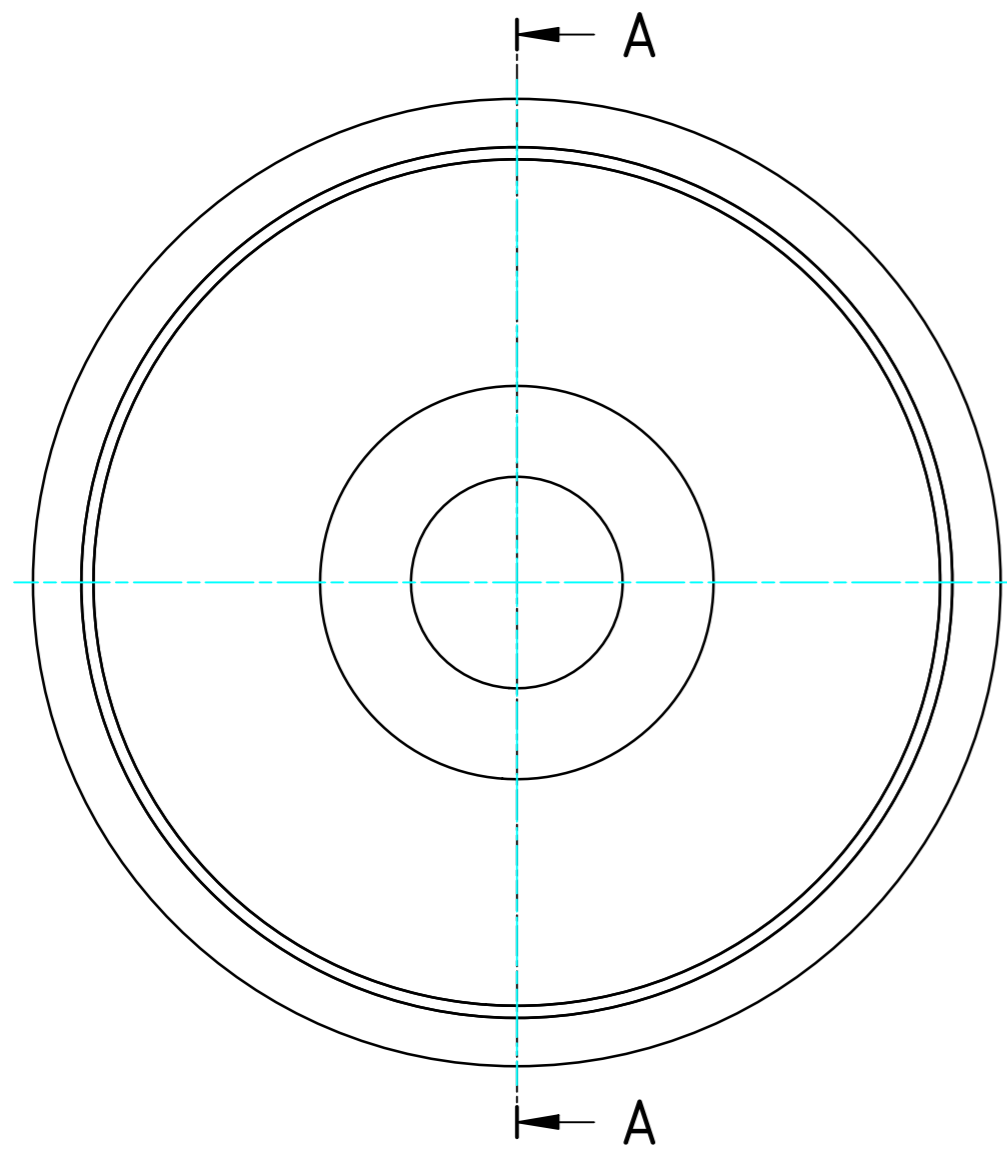
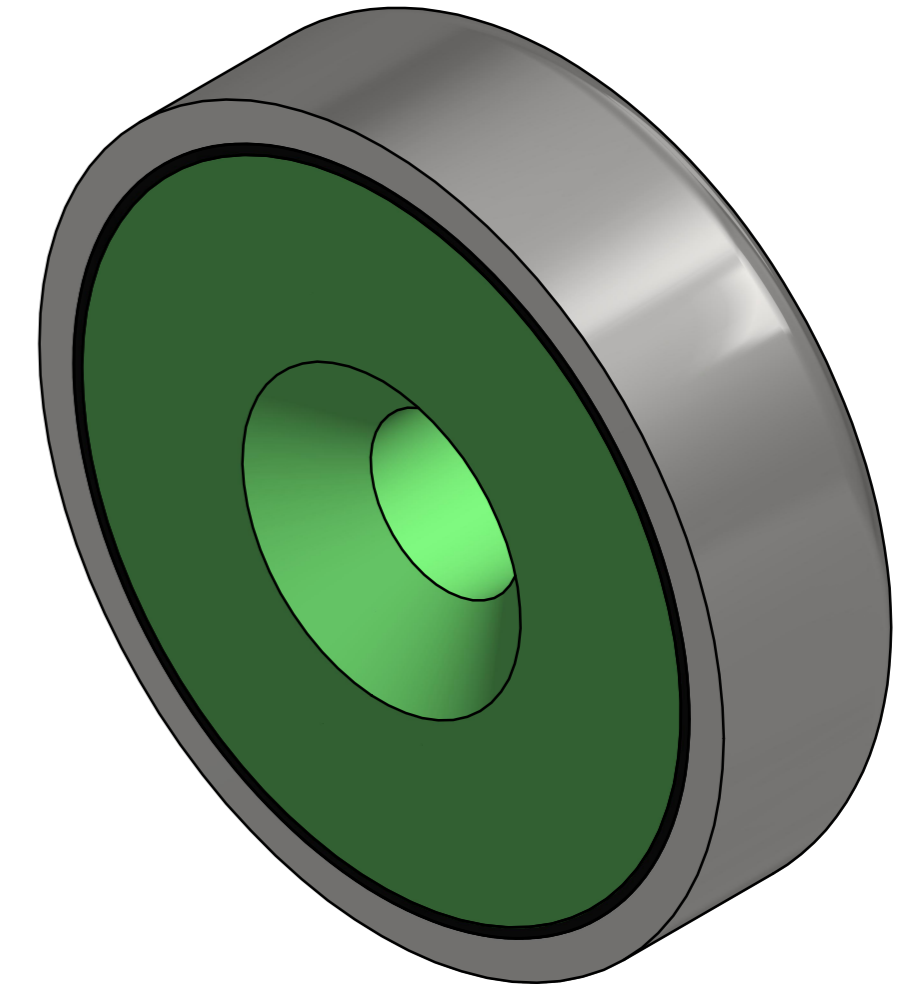
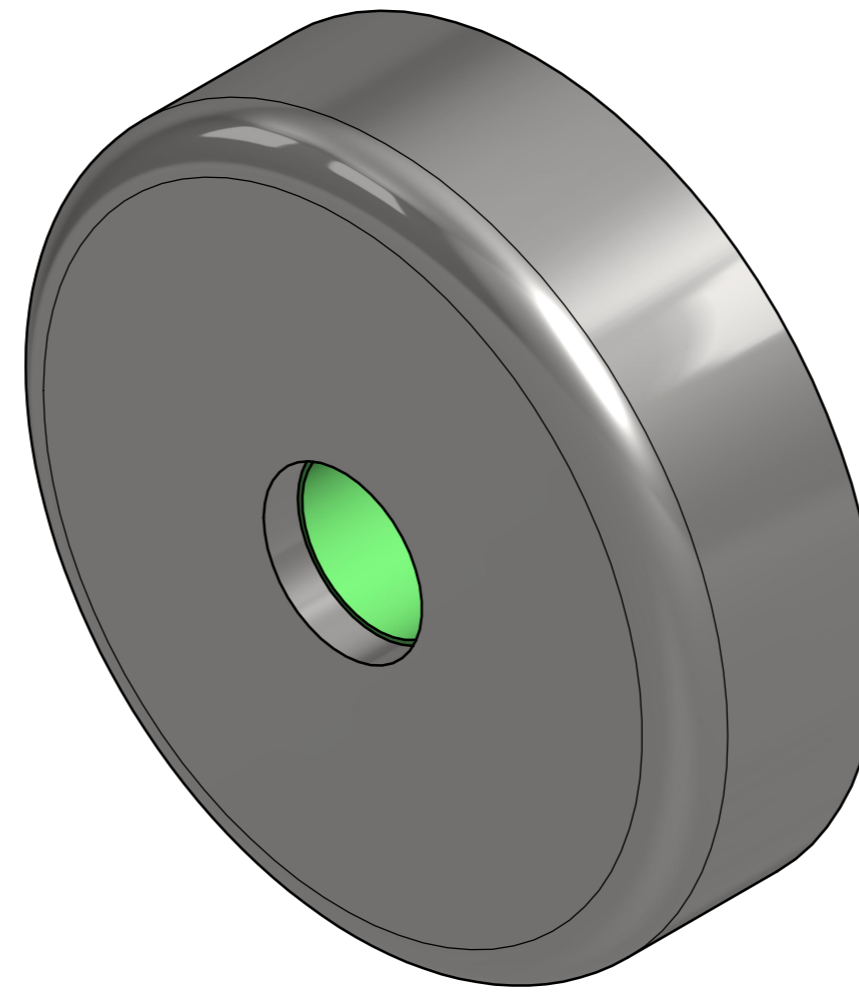

SURFACE TREATMENT: ZINC PLATED

RAW MAT.	1	Quantity	Material Number	Material Description	Length (mm)	Width (mm)
Drawn:	PV	Weight (kg):	0,006	Extra info: POTMAGNET FERRITE	General tolerance: ISO 2768- mK	
Date:	5-8-2019	GOUDSMIT MAGNETICS			Drawn according: ISO268; ISO1101; ISO2553	
Spare part:	False	© All rights reserved. Reproduction is not permitted without written permission of GOUDSMIT Magnetic Systems BV			Status: Standard	
Quick search:	POTGM	Description: PM-HS-F-SG-D16x4.5xd3.5/6.5			Customer reference number: E0120181	
					Document number:	Doc.Rev:
					Part number:	Rev:
					GM16600	-