

DOC.NR.	REV	DATE	BY	DESCRIPTION
E0120190	-	25-9-2019	PV	ORIGINAL DRAWING
E0120190	A	22-6-2020	TM	TOLERANCE Ø4+0.4 WAS Ø4±0.2 TOLERANCE Ø9.4+1 WAS Ø9.4+1.5

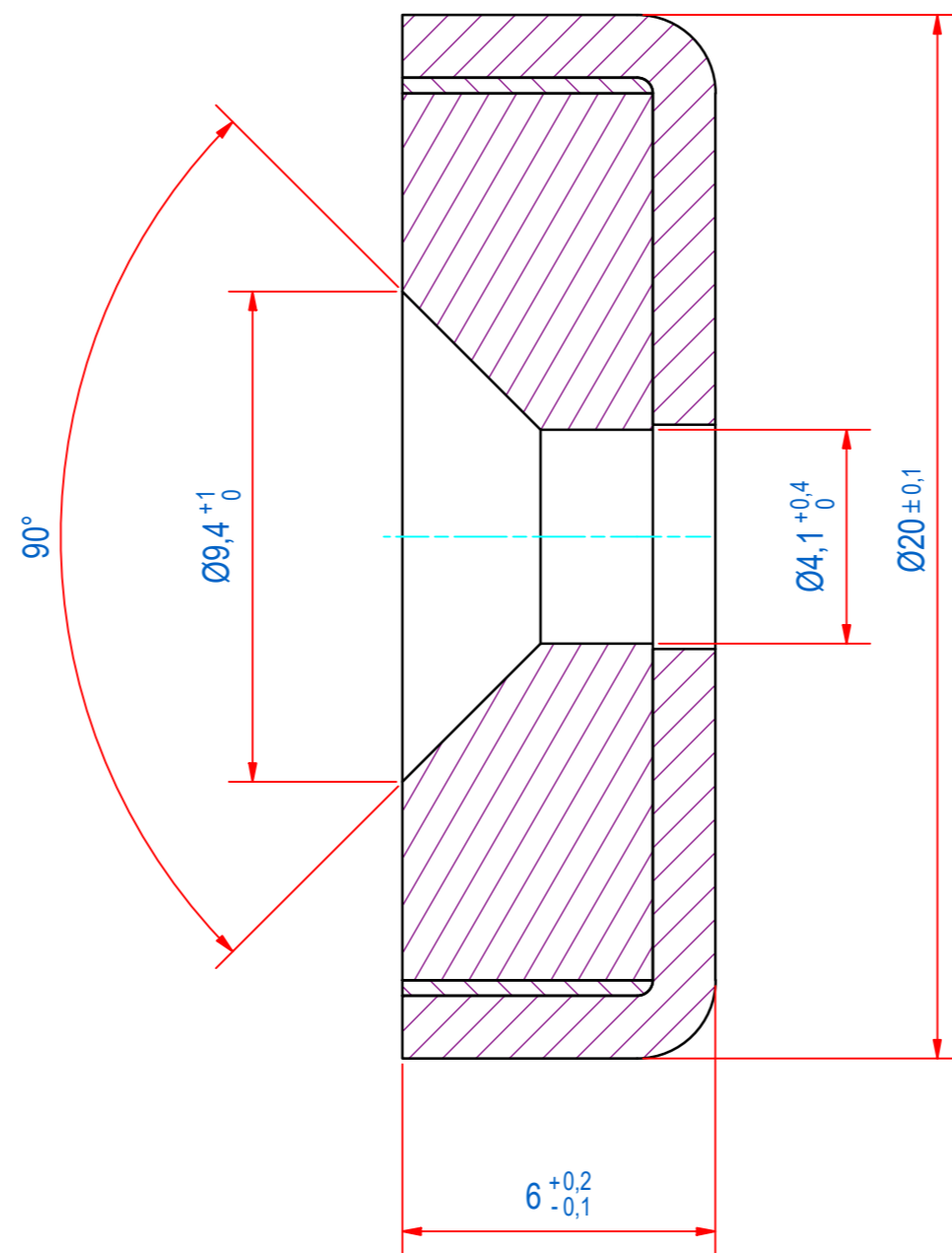
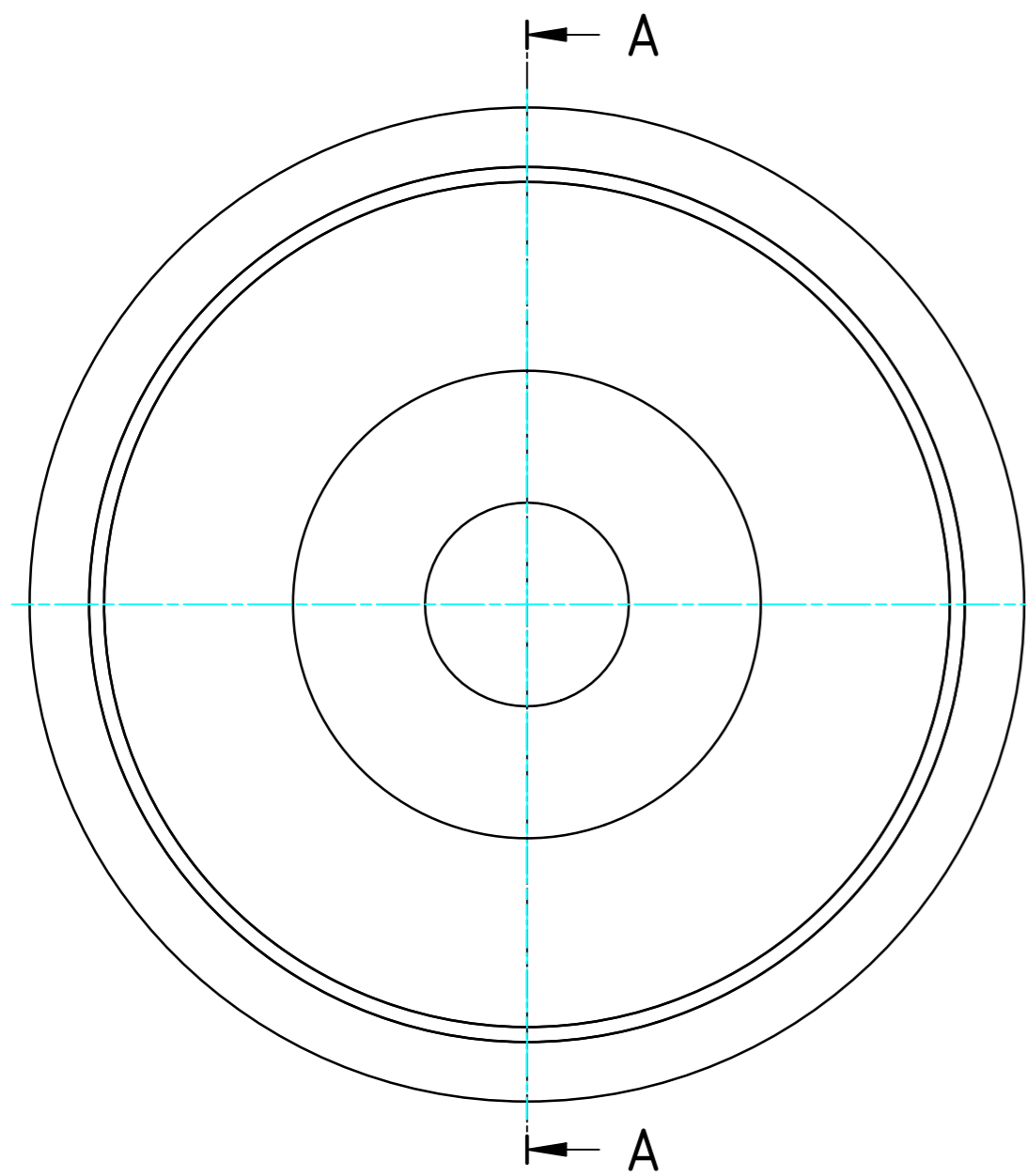
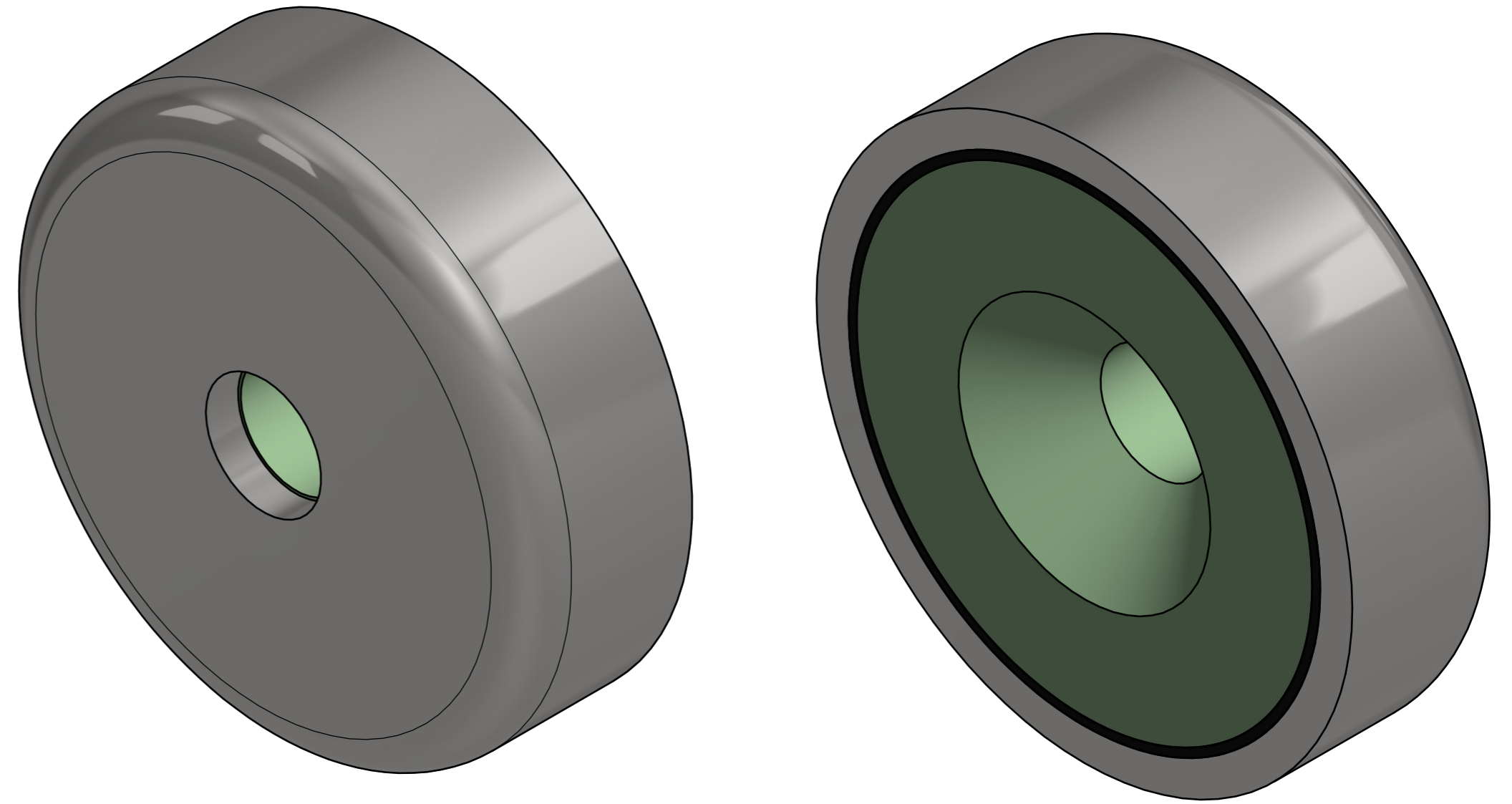

SURFACE TREATMENT: ZINC PLATED

RAW MAT.	1	Quantity	Material Number	Material Description	Length (mm)	Width (mm)
Drawn:	PV	Weight (kg):	0,010	Extra info:	General tolerance: ISO 2768- mK	
Date:	5-8-2019	Sheet:	A2	POTMAGNET FERRITE	Drawn according: ISO268; ISO1101; ISO2553	
Spare part:	False	Source:			Status: Standard	
Quick search:	POTGM	© All rights reserved. Reproduction is not permitted without written permission of GOUDSMIT Magnetic Systems BV			Customer reference number:	
Description:	PM-HS-F-SG-D20x6xd4.1/9.4			Document number:	E0120190	Doc.Rev: A
				Part number:	GM16601	Rev: A