

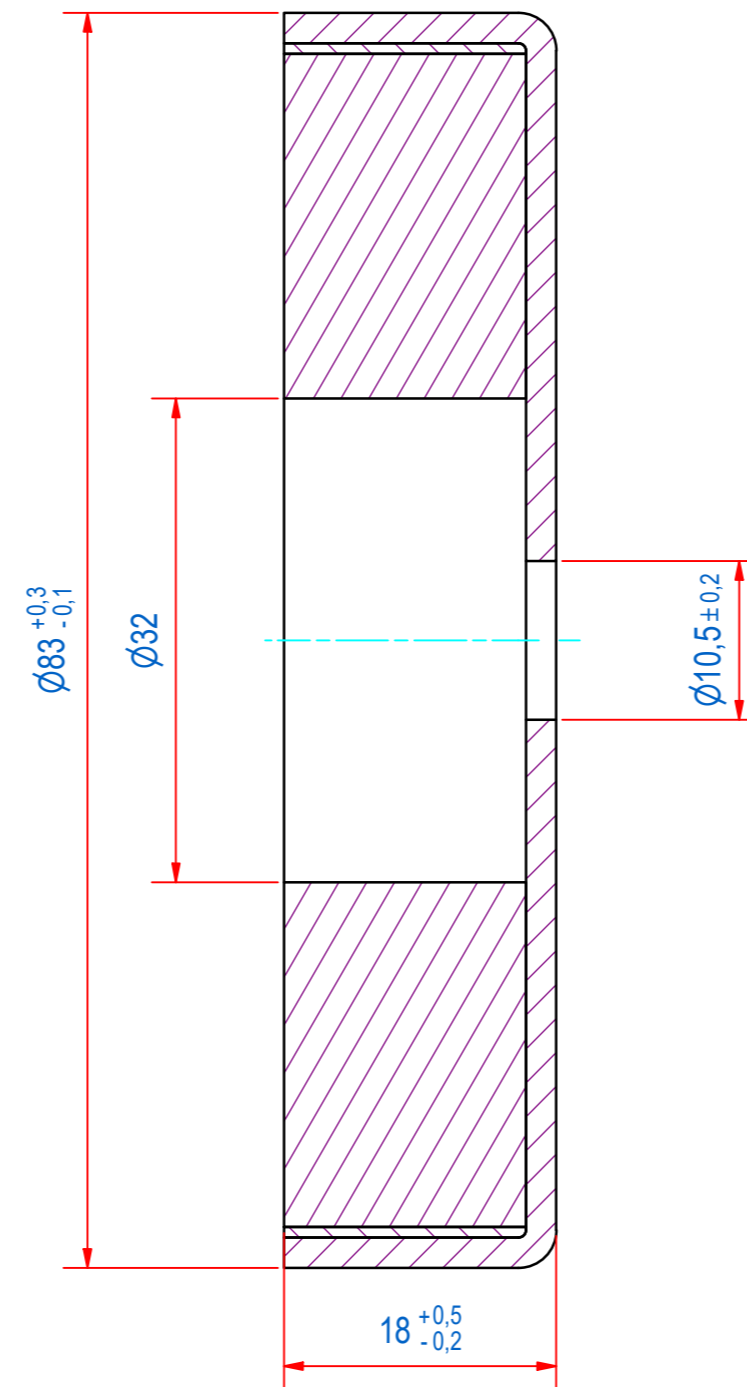

DOC.NR.	REV	DATE	BY	DESCRIPTION
GM16608	-	24-8-2020	TM	ORIGINAL DRAWING

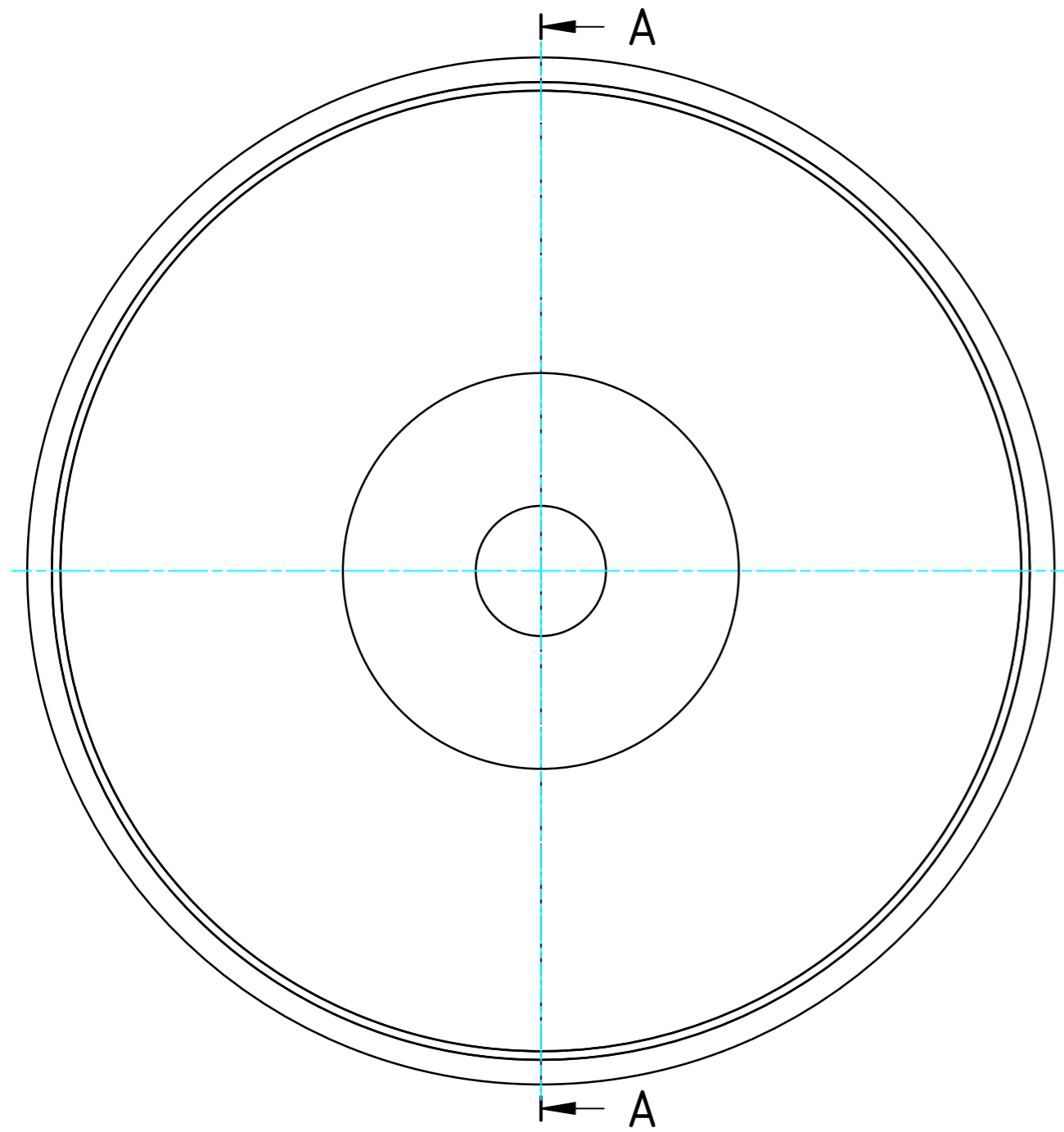
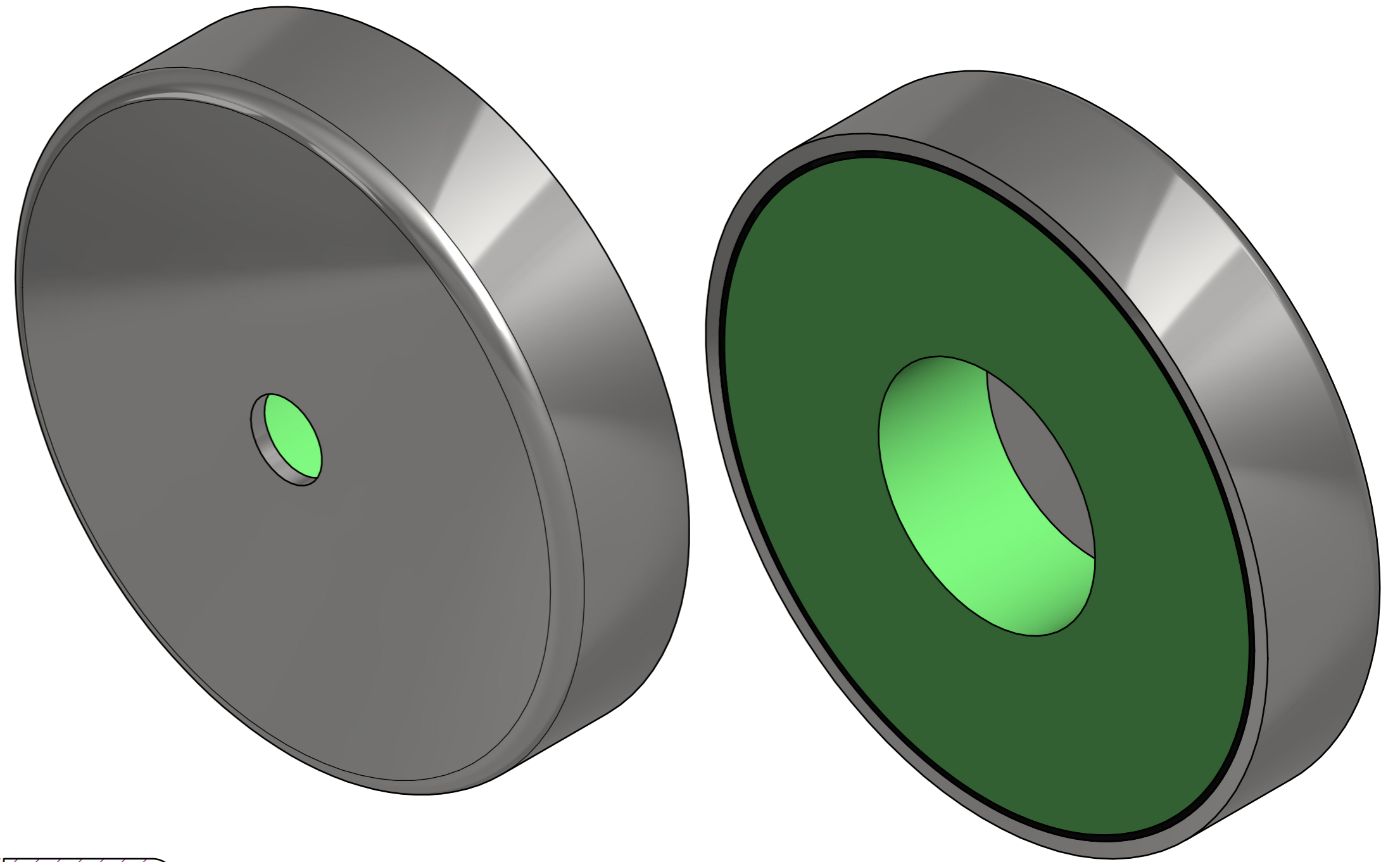

SURFACE TREATMENT: ZINC PLATED

RAW MAT.	1	Quantity	Material Number	Material Description	Length (mm)	Width (mm)
Sheet:	A2	Extra info:	POTMAGNET FERRITE		General tolerance:	ISO 2768 - mK
Drawn:	TM	Weight (kg):	0,64		Drawn according:	ISO268; ISO1101; ISO2553
Date:	24-8-2020	Quick search:	POTGM		Status:	Standard
Spare part:	False	Source:			Customer reference number:	
Description:	PM-HB-F-SG-D83x18xd10.5/32			Document number:	GM16608	Doc.Rev:
				Part number:	GM16608	Rev: